



Wireless Data Communications

Hopper Plus 120-24 Installation and Configuration Guide

5700-0037

Dec 2000 Rev 2

Contents

Notices	vii
Copyright Notice	vii
Regulatory Notice	vii
Other Notices	viii
Warranty & Repair	viii
Contacting Wi-LAN	viii
Contacting the Technical Assistance Center	ix
Wi-LAN Product Information	ix
Description	I
Features	I
About Spread Spectrum	I
About Hopper Plus Units	2
Some System Applications	3
Making a Simple Wireless Bridge	3
Creating a Simple Wireless Network	3
Creating a Network with Cells	5
Using a Repeater Base	6
Building a WAN	6
Hardware Description	7
Shipping Package Contents	7
Hopper Plus 120-24 Unit	7
Hopper Plus 120-24 Specifications	10
Installation	13
Overview	13
Obtain Network Plan	14
Assemble Units	14
Checking the Shipping Contents	14
Assembling Hopper Plus Units	14
Checking the Power	15

Pre-Configure Units	16
Configuring a Base Station	16
How to Use the Main Menu	17
Configuring a Remote Unit	19
Bench Test Units	21
Establishing a Basic RF Link	21
Testing a Basic RF Link	23
Performing Simple Network Tests	24
Install Units	27
Point-to-Multipoint Installation	27
Co-Location Installation	28
Test Network	28
Adding to a Network	28
Preventative Maintenance and Monitoring	29
Configuration	31
Overview	31
Main Menu	31
Accessing the Main Menu	32
Accessing the Main Menu with HyperTerminal®	32
Accessing Units via telnet	33
Setting VT100 Arrows	33
Configuring with the Main Menu	34
How to Use the Main Menu	34
Unit Identification	35
Viewing Unit Identification	35
Assigning Unit Identification Information	36
Hardware/Software Revision	37
Viewing System Revision Information	37
System Software ROM Images	38
Viewing System Software ROM Images	38
System Current Status	39
Viewing System Current Status	39
Network Configuration	40
Viewing Internet IP Addresses and Subnet Mask	40
Setting the Internet IP Address	41
Setting the IP Subnet Mask	41
Setting the Default Gateway IP Address (future)	42
Setting the SNMP NMS Trap IP Address (future)	42
Setting the MAC Filter Entry Age Time Minutes	42
IP Filter Configuration	43
Viewing IP Filter Configuration	43

Enabling IP Packet Filtering	45
Enabling IP Address Filtering	45
Setting IP Address Filter Range	46
Setting the IP Filter Base Address	46
RF Station Configuration	47
Viewing Current RF Station Configuration	47
Setting the Operating Mode	49
General Equipment Setup for Performing RF Tests	50
Setting Test Mode Timer Minutes	51
Performing Link Monitor Test (Normal Mode)	52
Performing Transmit and Receive Tests	55
Performing the RSSI Test	57
Setting the RF Transmit Status	58
Setting the Link Monitor Period	59
Setting Maximum Remote Distance (Base Station Only)	60
Setting Link Monitor Remote Station Rank	61
Adjusting Throttling (Remote Station Only)	62
Radio Module Configuration	63
Viewing the Radio Module Configuration	63
Setting Config Test Minutes	65
Setting the Station Type	66
Setting the Station Rank	67
Setting the Center Frequency	68
Setting Security Passwords	69
Setting the Scrambling Code	70
Setting the Acquisition Code	71
Setting a Base to Repeater Mode (Base Station Only)	72
Setting System Symmetry Type (Base Station Only)	74
Setting Dynamic Polling Level (Base Station Only)	75
Setting Remote Unit RF Group	76
Rebooting and Saving RF Module Configurations	79
RF/Ethernet Statistics	81
Viewing RF/Ethernet Statistics	81
System Security	84
Viewing System Security	84
Assigning Community Names	86
Setting Menu Passwords	87
Allowing Remote Access and Configuration	89
Setting the Auto Logout Minutes	90
System Commands	91
Viewing System Command Menu	91
Setting Default System Image	92
Setting the Reboot System Image	93
Rebooting the Current Image	93
Restoring Factory Configurations	94
Resetting Radio and Ethernet Statistics	95
Link Monitor Display	96
Viewing Link Monitor Statistics	96
Logout	97

Logging Out	97
Setting Operating Mode with the MODE Button	97
Selecting RF Tests with the MODE Button	98
Command Line Interface	99
Troubleshooting	101
Administrative Best Practices	101
Troubleshooting Areas	102
Troubleshooting Chart	103
Appendix A: Planning Your Wireless Link	107
Planning the Physical Layout	107
Determine the Number of Remotes	107
Ensure LOS and Determine Coverage Area	107
Measure the Distance Between Units	108
Determine Shelter, Power and Environmental Requirements	108
Determining Antenna and Cable Requirements	108
Determining Unit Configuration Settings	109
Calculating a Link Budget	109
System Gain	110
EIRP (Effective Isotropically Radiated Power)	110
Antenna Gain	111
Propagation Loss	111
Fresnel Zone	111
Cable Loss	112
Path Loss	112
Fade Margin	112
Link Budget Example	113
Antenna Basics	114
Antenna Parameters	114
Implementation Considerations	115
Selecting Antennas	116
Wi-LAN's Antenna Selection	116
Antenna Installation Factors	117
Minimal Clearance Above Obstructions	118
Installing Antennas	118
Fine-tuning Antennas	119
Co-locating Units	119
Appendix B: Using HyperTerminal	121
Starting HyperTerminal	121
Determining the Communications Port	126

Appendix C: Configuring a Simple Data Network	127
Checking Network Adaptor Installation	127
Configuring the Network	128
Enabling the Sharing Feature on the Hard Disk Drive	131
Appendix D: SNMP	133
About SNMP MIB	133
Wi-LAN Object Identifier Nodes	134
Using SNMP	134
Using Object Identifier Nodes	135
Appendix E: Technical Reference Information	147
Front Panel LEDs	147
DC Power Plug Pinout	148
Appendix F: Menu Map	149
Appendix G: Upgrading Software	151
Obtaining New Software Images	151
Downloading Image Software	151
Activating New Software Images	153
Removing Old Software Images	153
Glossary	155
Index	165



Notices

Copyright Notice

Copyright© 2000 Wi-LAN, Inc.

All rights reserved.

This guide and the application and hardware described herein are furnished under license and are subject to a confidentiality agreement. The software and hardware can be used only in accordance with the terms and conditions of this agreement.

No part of this guide may be reproduced or transmitted in any form or by any means—electronic, mechanical, or otherwise, including photocopying and recording—without the express written permission of Wi-LAN, Inc.

While every effort has been made to ensure that the information contained in this guide is correct, Wi-LAN, Inc. does not warrant the information is free of errors or omissions.

Information contained in this guide is subject to change without notice.

Regulatory Notice

The Hopper Plus 120-24 product presented in this guide complies with the following regulations and/or regulatory bodies.

- RSS-139 of Industry Canada
- FCC Part 15
- CEPT/ERC Recommendations, ETS 300-328, ETS 300-826, and EN 60950

Operation is subject to the following two conditions.

- This device may not cause interference
- This device must accept any interference, including interference that may cause undesired operation of the device.

This equipment generates, uses, and radiates radio frequency and, if not installed and used in accordance with this guide, may cause harmful interference to radio communications. However, there is no guarantee that interference will not occur in a particular installation.

If this equipment does cause harmful interference to radio or television reception, which can be determined by turning the equipment off and on, the user is encouraged to try to correct the interference by one or more of the following methods.

- Reorient or relocate the receiving antenna
- Increase the separation between the equipment and receiver
- Connect equipment to an outlet on a circuit different from that to which the receiver is connected
- Consult the dealer or an experienced radio/TV technician for help
- Selecting and testing different channels, if employing 2.4 GHz equipment

As the Hopper Plus 120-24 is used on a license-exempt, non-frequency coordinated, unprotected spectrum allocation, and thus can be subject to random unidentified interference, applications must not be those of a primary control where a lack of intercommunication could cause danger to property, process, or person. An alternative fail-safe should be designed into any system to ensure safe operation or shut down, should communication be lost for any reason.

Other Notices

- Changes or modifications to the equipment not expressly approved by Wi-LAN, Inc., could void the user's authority to operate the equipment.
- Appropriately shielded remote I/O serial cable with the metal connector shell and cable shield properly connected to chassis ground shall be used to reduce the radio frequency interference.
- FCC radio frequency exposure limits may be exceeded at distances closer than 23 centimeters from the antenna of this device.
- All antenna installation work shall be carried out by a knowledgeable and professional installer.
- Use only a power adapter approved by Wi-LAN.

Warranty & Repair

Please contact the party from whom you purchased the product for warranty and repair information. Wi-LAN provides no direct warranty to end users of this product.

Contacting Wi-LAN

Users of this equipment who require assistance should call their distributor.

Distributors may contact Wi-LAN's Technical Assistance Center (TAC) to help troubleshoot Wi-LAN products and help with planning wireless networks.

Contacting the Technical Assistance Center

You can contact Wi-LAN's Technical Assistance Center at the numbers listed below.

- | | |
|----------------|--|
| Canada and USA | Call toll free: 1-866-702-3375
Business hours: 7:30 a.m. to 4:30 p.m. Mountain Standard Time (GMT-7:00) |
| International | Call: 1-403-204-2767
Business hours: 7:30 a.m. to 4:30 p.m. Mountain Standard Time (GMT-7:00) |
| All locations | Send an e-mail message to:
techsupport@wi-lan.com |

Wi-LAN Product Information

To obtain information regarding Wi-LAN products, contact the Wi-LAN distributor in your region, call 1-800-258-6876 to speak with a Wi-LAN sales representative or visit our web site at www.wi-lan.com.

Description

Features

The Hopper Plus 120-24 is a wireless Ethernet bridge that provides high-speed, wireless connectivity at a fraction of the cost of wired solutions. It operates over the license-exempt 2.4 – 2.48350 GHz ISM radio band and has a maximum raw wireless data rate of 12.0 Mbps.

- Provides wireless connectivity at speeds up to eight times faster than regular T1 lines, making the Hopper Plus 120-24 ideal for providing high-speed Internet access or for wirelessly extending existing communications infrastructures.
- Supports point-to-point, point-to-multipoint, and multipoint-to-multipoint networks. Contentionless polling ensures efficient access to remote data networks.
- Is self-contained and easy to use. Simply connect a Hopper Plus 120-24 to each LAN segment, and the unit automatically learns where nodes are located on the network and performs dynamic packet filtering to ensure the local LAN traffic does not overload the wireless connection.
- Uses Wi-LAN's patented Multi-Code Direct Sequence Spread Spectrum (MC-DSSS) technology, which makes the unit spectrally efficient and resistant to interference. MC-DSSS technology increases data throughput by as much as ten times compared to traditional spread spectrum technology.
- Other features include IP address filtering, throughput throttling and monitoring, high security and reliability, and a flash-code upgrade path. SNMP, Telnet and RS-232 management enable users to manage, configure and monitor their wireless network with ease.

About Spread Spectrum

The FCC allocates three license-free frequency bands (called the ISM bands) to a radio technique known as spread spectrum communication. The bands are located at 900MHz, 2.4 GHz, and 5.7 GHz (shown in the following illustration). The Hopper Plus 120-24 operates with spread spectrum technology over the 2.4 – 2.4835 GHz band.

License-Free ISM Bands

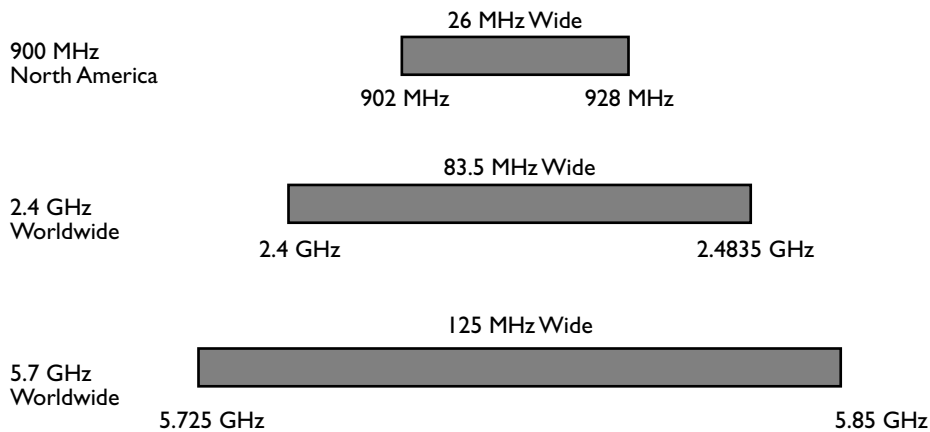

Direct Sequence Spread Spectrum (DSSS) technology converts a data stream into packets and spreads the packets across a broad portion of the RF band. The particular spread pattern depends upon a code. With multi-code DSSS (MC-DSSS), multiple codes and spread patterns are employed. A spread spectrum receiver reconstructs the signal and interprets the data.

Some advantages of DSSS are as follows.

- **Fast throughput:** A wide bandwidth means fast data throughput.
- **Resistant to interference:** DSSS overcomes medium levels of interference and multipath problems.
- **Security:** There must be a decoder at the receiving end to recover data (a Hopper Plus can only talk to another Hopper Plus). Data is transmitted at irregular time intervals. Upon request, Wi-LAN can assign a customer a data packet security code so that a customer can only receive transmissions from another Hopper Plus with the same code.
- **Low probability of detection:** Due to a low amplitude signal and wide bandwidth.
- **No license fee:** A license fee is not required if used in the specified radio bands, transmitter power is limited, and a non-standard antenna connector is used.

About Hopper Plus Units

Hopper Plus units can function as base stations, remote units or repeater bases.

Base Station: At least one unit in your wireless network must be a base station. A base station acts as the central control unit of the wireless network. The base station polls all remote units and controls how traffic is routed to and from remotes. The base usually connects to a major access point of the wired network. The antenna of the base station must be capable of transmitting and receiving radio signals to and from all the remote units in a system. If remotes are spread over a large area, an omni-directional antenna is usually required. See [Configuring a Base Station](#), page 16 for information about setting up a base station.

Remote Units: Remote units receive and transmit wireless data to the base station. You need at least one remote unit for each wireless link. Remotes can limit the amount of data passed by the remote (a function called throttling), and they can filter data packets based on their IP address. Because remote units communicate only with the base station, their antennas can be more directional and have higher gains than base antennas. See [Configuring a Remote Unit](#), page 19 for information about setting up a remote unit.

Repeater Base: A base station can be configured as a repeater base. A repeater is needed when remote units cannot communicate directly with each other, but direct transfers of data between them are necessary (as in a true WAN). When configured as a repeater, the base station passes data packets between remote stations based on the remote group status and a list of MAC (Media Access Control) addresses that the base station automatically builds. The repeater uses a method called "store and forward" to receive data from the originating remote and to pass data to the destination remote. See [Setting a Base to Repeater Mode \(Base Station Only\)](#), page 72 for more information.

Some System Applications

You can build a wireless network from Hopper Plus units and various other components such as cables and antennas. The following section shows some simple examples of Hopper Plus applications.

Making a Simple Wireless Bridge

The simplest example of using a Hopper Plus 120-24 is a point-to-point wireless bridge that connects two wired network segments or LANs. Two Hopper Plus units are required: a base station and a remote unit.

Point-to-Point Wireless Bridge

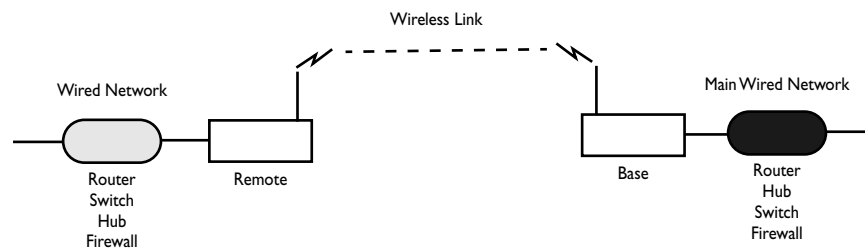

Creating a Simple Wireless Network

You can create a point-to-multipoint wireless network by adding several remote units to a base station. A base station can support up to 1000 remotes, however, Wi-LAN recommends no more than 225 remotes per base station to ensure high levels of data throughput. See [Determine the Number of Remotes](#), page 107 for more information.

Point-to-Multipoint Wireless Network

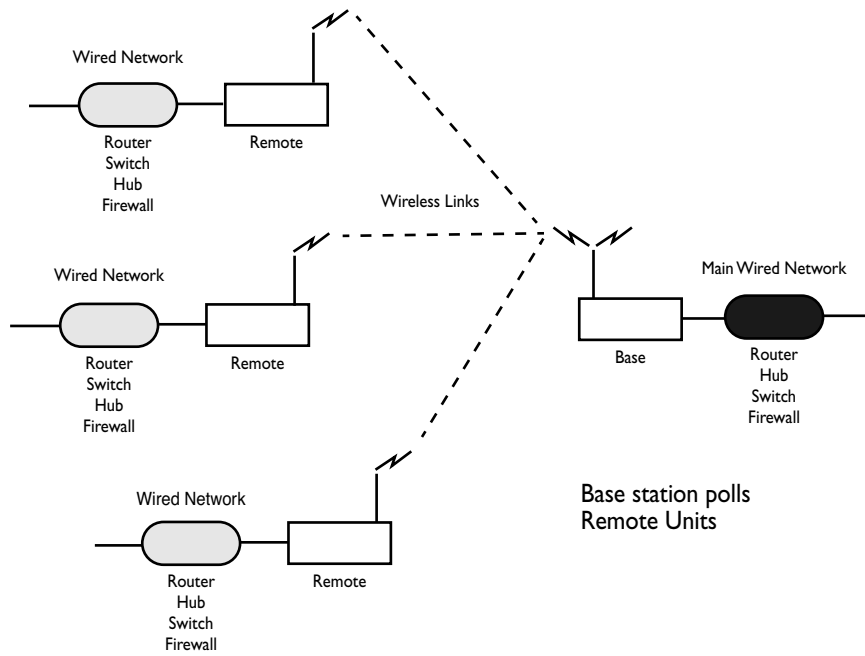

Direct remote-to-remote communication can occur if a direct RF link can be established between remotes, and if remotes are in the same RF group.

Remote-to-Remote Communication

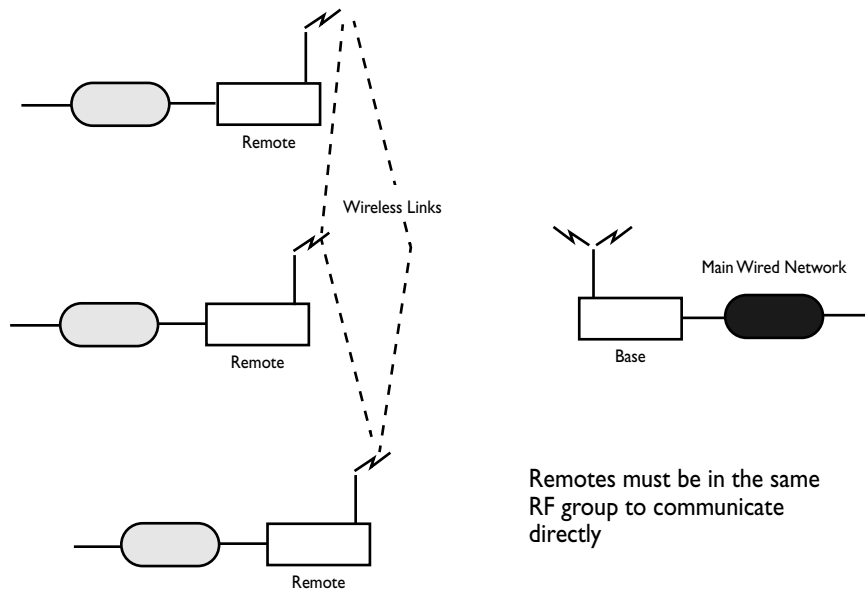

Creating a Network with Cells

Cells or data nodes can be created with Hopper Plus units to maximize coverage, minimize interference, and increase data throughput. Directional antennas are mounted on a mast to divide cells into sectors. Each sector is connected to an antenna and a base station. Directional antennas increase signal gain within the sector and increase the distance possible between base stations and remotes. Center frequency, acquisition code and antenna polarization techniques are used to isolate sectors. The increase in data rate depends on the number of sectors. For example, the data rate of Cell 1 in the diagram below is 37.5 Mbps (12 Mbps x 3 sectors x 75%; 25% is overhead). Cells are distributed across a service area and can be linked to each other via a wireless link or a fiber optic cable.

LAN with Cells and Sectors

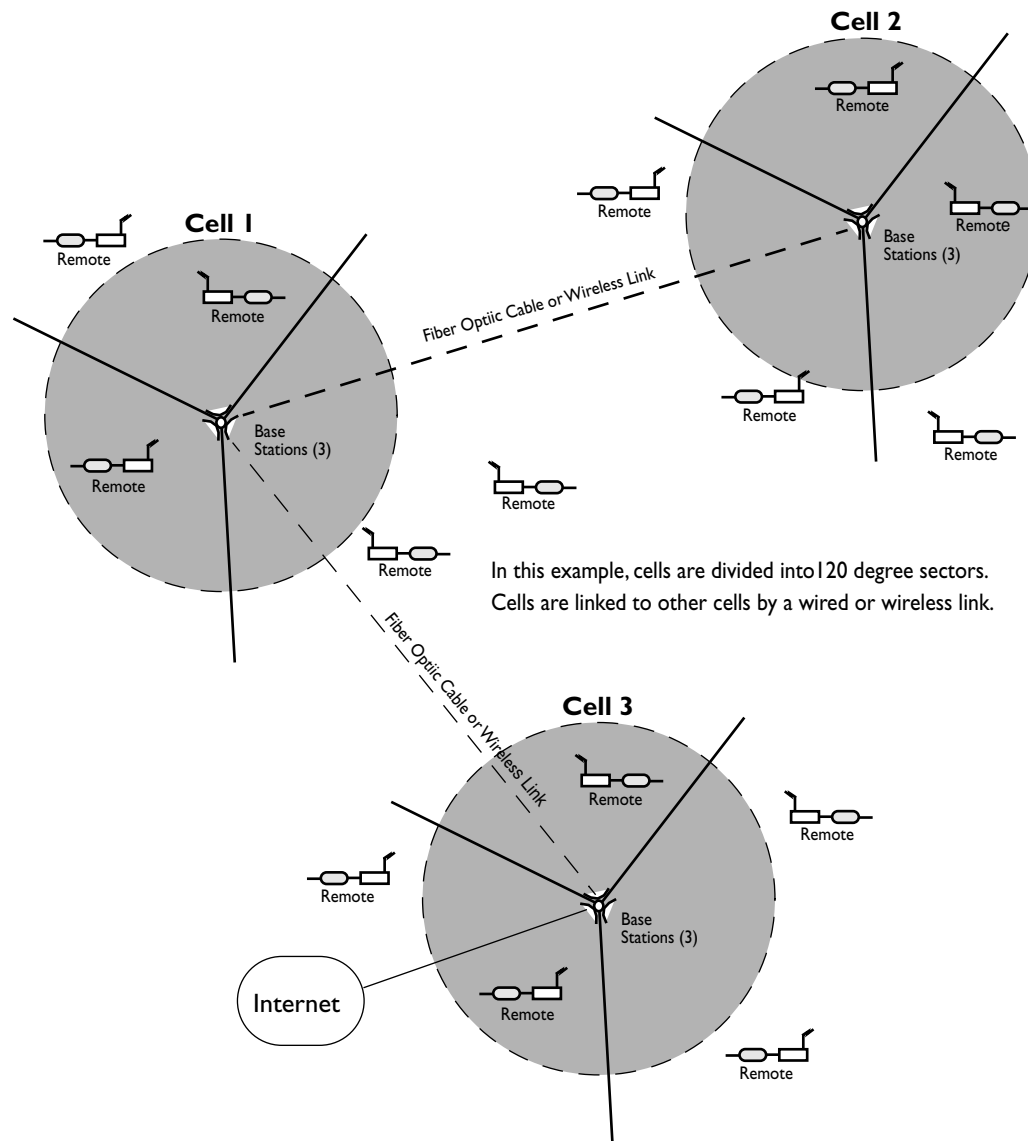

Using a Repeater Base

A base station can function as a repeater to enable wireless data communication around physical obstacles such as tall buildings or mountains. The repeater passes data around the obstacle to any remote in the same RF group.

Base Station as a Repeater

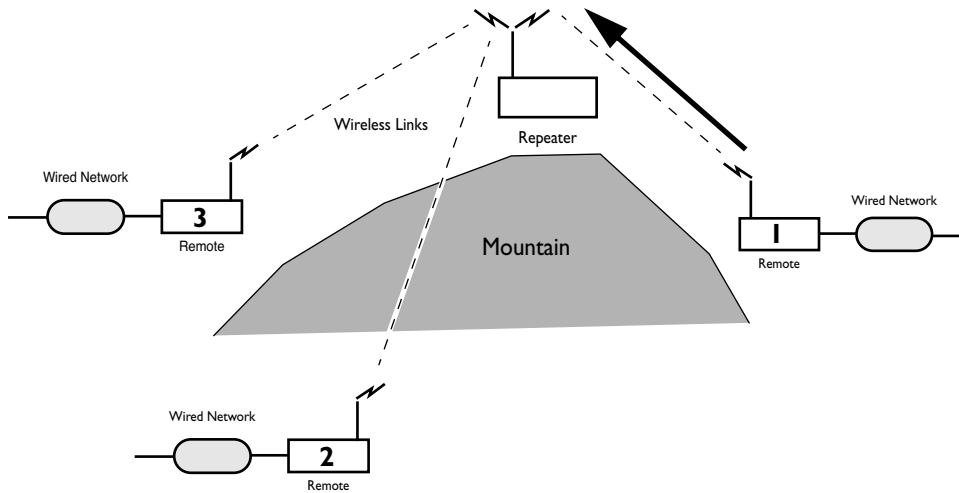

Building a WAN

LAN segments can be linked with Hopper Plus units to build a WAN (Wide Area Network). Wi-LAN networks are installed in many locations around the world. You can contact Wi-LAN for help designing your network.

Hardware Description

Shipping Package Contents

The shipping package contains the following items.

- Hopper Plus unit
- Indoor (dipole) antenna
- Power supply, table top adapter (43W 12 Vdc)
- Power supply cord
- Installation and Configuration Guide
- Warranty Card

If any of the above items are not included in the Hopper Plus 120-24 shipping package, contact Wi-LAN customer support.

You may also require the following items.

- Cable, straight-through ethernet RJ45, when connecting a unit to a hub
- Cable, crossover ethernet cable RJ45, when connecting directly to the Ethernet port of a PC
- Cable adapter, DB25F to DB9M
- RS-232 DB25 serial cable

You can purchase these items and other parts from Wi-LAN or any authorized supplier.

Hopper Plus 120-24 Unit

The Hopper Plus 120-24 has connectors and LEDs on the front and back panels.

Front Panel

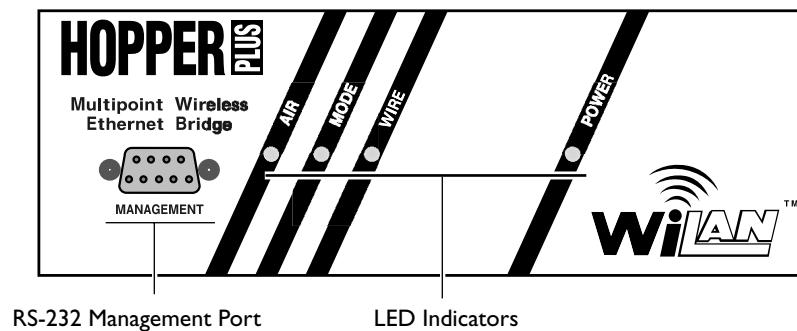

The front panel connector and LEDs are described below. The color of a LED indicates its status. See [Front Panel LEDs](#), page 147 for detailed information

MANAGEMENT Port	RS-232, DB9 connector used to communicate with a PC. Use this port to locally configure and test a Hopper Plus
AIR LED	Color of LED indicates the transmit/receive status of the wireless link: transmit = red, receive = green, orange = transmit and receive, or listen = off
MODE LED	Color of LED indicates the operating mode of a unit: Normal Mode, Transmit Test, Receive Test, RSSI Test
WIRE LED	Color of LED indicates the transmit/receive status of the wire link: transmit= red, receive = green, orange = transmit and receive, or listen = off
POWER LED	Shows the status of the unit's power

Connectors for power, antenna and wired network are located on the back panel, as well as a mode button and a link LED.

Rear Panel

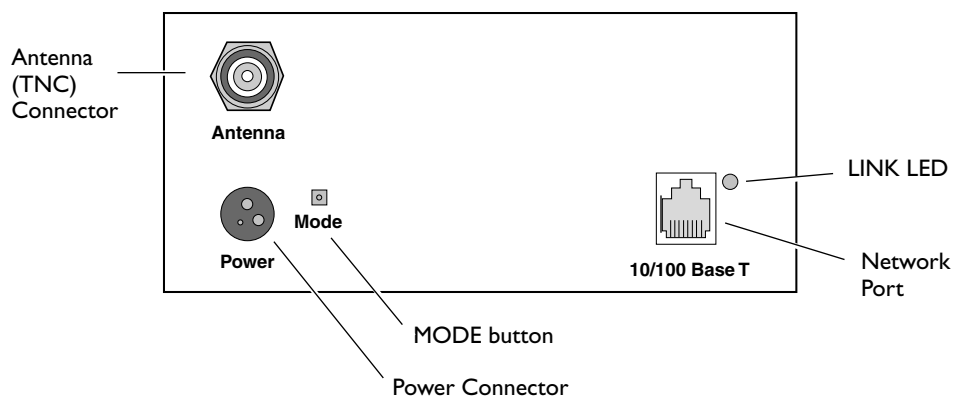

Items located on the back panel are described below.

ANTENNA Connector	TNC antenna port is located at the top left of the rear panel. This port should always be connected to an antenna directly or through a 50 ohm coaxial cable
POWER Connector	3-pin power connector. See DC Power Plug Pinout , page 148 for detailed pinout illustration
MODE Button	Mode button can be used to set the operating mode of a unit without a terminal. See Setting Operating Mode with the MODE Button , page 97 for information about the mode button
10/100BASET	Standard RJ45 female connector. To connect to a PC Ethernet card, you must use the crossover twisted-pair cable. To connect to a hub, use a straight-through twisted-pair cable
LINK LED	Color of LED indicates the data rate and status of the twisted-pair connection Green = 10BaseT link, functioning properly Orange = 100BaseT link, functioning properly Off = No link

Hopper Plus 120-24 Specifications

General Specifications

Modulation Method:	Multi-Code Direct Sequence Spread Spectrum (MC-DSSS)
Wireless Data Rate:	12 Mbps
RF Frequency Range:	2.4 - 2.4835 MHz (unlicensed ISM band)
Number of Center Frequencies:	7 independent, 3 concurrent
Power Requirements:	43 W @ 12VDC (via 110/240 VAC 50/60 Hz adaptor)
Physical:	Size: 24 x 8 x 20.3 centimeters (9.5 x 3.2 x 8.0 inches) Weight: 1.94 kg

Radio Specifications

Antenna Connector:	TNC
Output Power:	+20 dBm +/- 1.5 dBm (North America & International) +12 dBm +/- 1.5 dBm (Europe)
Receiver Sensitivity:	- 81 dBm
Processing Gain:	> +10 dBm

Network Support

Packet Format:	IEEE 802.3 and Ethernet II (High-level protocol transparent)
LAN Connection:	10/100BaseT (autonegotiates)
Bridge Functionality:	Local Packet Filtering (self-learning) Static IP address filtering Dynamic polling of remotes User configurable data rate (throttling) Software is upgradeable online via ftp

Wireless Networking Protocols

Network Topologies:	Point-to-Point, Point-to-Multipoint, Multipoint-to-Multipoint
Repeater Mode:	User Configurable
RF Collision Management:	Dynamic Polling with Dynamic Time Allocation

Security

Data Scrambling:	User Configurable
Data Security Password:	Security password of up to 20 bytes in length (10^{48} combinations)

Configuration, Management, and Diagnostics

Configuration Methods:	SNMP, telnet and RS-232 Management Port
SNMP:	Version 1 compliant (RFC 1157), MIB standard and enterprise (RFC 1213)
Management Port Functionality:	Supports system configuration, security, access control, wireless LAN diagnostics and management, menu-driven ASCII interface via RS-232 DB-9 connector

Environment

Units must be located in a weatherproof environment with an ambient temperature from 0 to 40° Celsius and humidity 0 – 95% non-condensing

Installation

Overview

This section explains how to install Hopper Plus units. You will first assemble, configure and test units in a controlled environment so that any problems can be solved easily, and then install units in the field. By going through this process, you will ensure a successful installation, save time spent on-site, and reduce travel from site to site.

The following basic process should be followed.

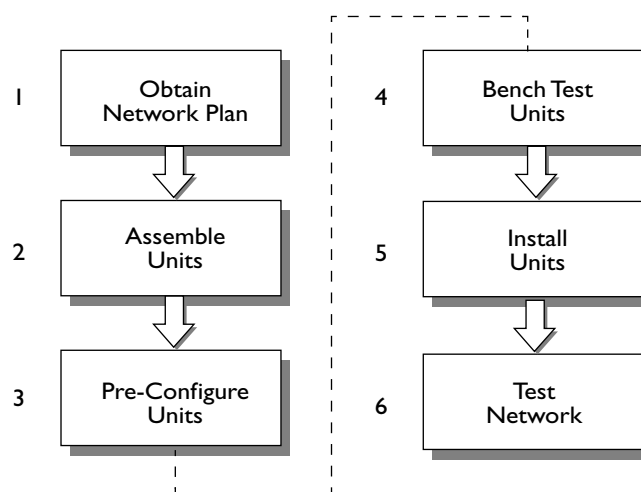

1. Obtain the network plan, equipment and tools.
2. Assemble units
 - Check the contents of each Hopper shipping package to ensure that you have received the required parts.
 - Connect the indoor antenna, connect the power supply unit, and check the power.
3. Pre-configure units—Configure units according to the network plan.
4. Bench test units—Test basic RF and network operation of units in a controlled environment.
5. Install units—Place the tested units in their field locations and connect them to antennas, the wired network, and DC power.
6. Test Network—Test the operation of the installed network.

Obtain Network Plan

The network plan describes the network in detail, including the following.

- Type and number of units
- Physical layout
- Configuration settings for each unit
- Site names, IP addresses and links
- Antenna types, RF cables and cable lengths, surge suppressors, terminators
- Network cable types and lengths
- Grounding kits and backup power requirements
- Link budget
- Floor plans and equipment cabinet requirements

The network plan must be completed before any equipment is installed. See [Appendix A: Planning Your Wireless Link](#), page 107 for more information about network plans.

Check your equipment and tools: Ensure that you have all the required parts and equipment specified in the network plan. You will need some tools to install units—in addition to a standard tool kit, you will require a laptop PC with HyperTerminal® and RS-232 cable. You may require a spectrum analyzer, Site Master® communication test set, digital multimeter, 2-way radios, binoculars, strobe lights, ladder, and weatherproof caulking.

Assemble Units

Checking the Shipping Contents

Check the contents of each Hopper Plus shipping package to ensure that you have received all the materials. See [Shipping Package Contents](#), page 7 for a list.

Assembling Hopper Plus Units

► To assemble a unit

1. Connect the indoor antenna (supplied) to the ANTENNA port at the back of the unit.

Note: Indoor antenna may be different from the illustration.

WARNING

Always disconnect the ANTENNA before connecting the power cord. Otherwise, the antenna may be damaged.

2. Connect the power supply unit to the POWER connector at the back of the unit. The Hopper Plus 120-24 must be connected only to a Wi-LAN approved power supply unit with an output of 12Vdc. See [DC Power Plug Pinout](#), page 148 for pinout information.

Antenna and Power Connections

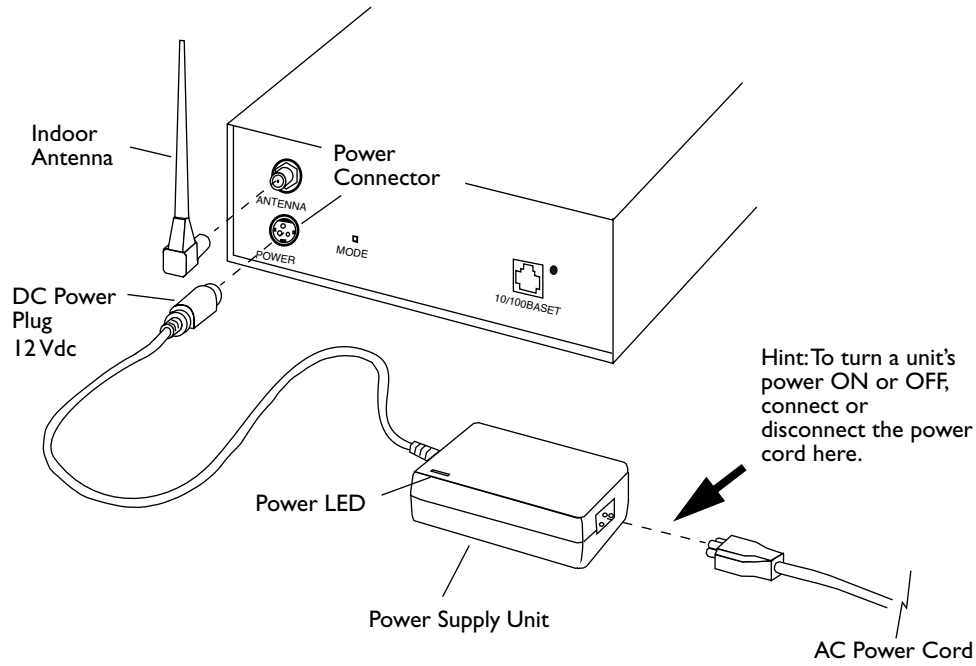

Note: Indoor antenna may be different from the illustration.

Checking the Power

► To check the power

1. Plug the AC power cord into the AC power outlet.
2. Plug the DC power plug (12Vdc) to the unit's power connector.
3. Plug the AC power cord into the power supply unit.
The green POWER LED on the front of the unit turns ON and the AIR, MODE and WIRE LEDs turn ON briefly then turn OFF.
The green POWER LED stays ON. The MODE LED stays OFF (indicating Normal mode). The AIR LED is orange, green, red or OFF. See [Front Panel LEDs](#), page 147 for more information about LEDs.

If the green POWER LED does not turn ON, check your AC power source and the power supply unit. Measure the power supply unit voltage at the DC Power Plug between pins 1 and 2. See [DC Power Plug Pinout](#), page 148. The output should be 12Vdc and the power supply unit power LED should be ON.

2. Start HyperTerminal® or another terminal emulation program (see [Appendix B: Using HyperTerminal](#), page 121 for details). Use the following communication settings: 9600 bps, 8 bits, no parity, 1 stop bit, no flow control.
3. Press **Enter**. The Hopper Plus Login window is displayed.

```

Wi-LAN Hopper Plus 120-24 Login

Software:   Rev 0.0.0 (Aug 25 2000 10:13:37)
Hardware:   Rev 0.0.0 (4MB SDRAM, 4MB Intel Flash)

Enter Password:

```

4. Type the default password (`supervisor`) and press **Enter**. The Main Menu is displayed.

Note: `supervisor` enables you to change the configuration settings with the Main Menu. See [Setting Menu Passwords](#), page 87 for more information about menu passwords.

Main Menu

```







Wi-LAN Hopper Plus 120-24 Main Menu

-> Unit Identification
   Hardware/Software Revision
   System Software ROM Images
   Current System Status
   Network Configuration
   IP Filter Configuration
   RF Station Configuration
   Radio Module Configuration
   RF/Ethernet Statistics
   System Security
   System Commands
   Link Monitor Display

Logout

```

How to Use the Main Menu

- To select an item from the Main Menu or a sub-menu, press the keyboard arrow keys   to move the cursor → next to item. Press the Enter key  **Enter** to open the data entry field.
- To scroll through items in the data entry field, press   . Press  **Enter** to select an item from the field.
- To exit from a menu, press the **Esc** key. 

5. Select **Network Configuration**. Check the network configuration information, the IP address and subnet mask settings. If necessary, change settings to match the network plan.

6. From the Main Menu, select **Radio Module Configuration** and press **Enter**. The Radio Module Configuration window is displayed.

Radio Module Configuration			
	New	Current	Flash
	-> Remote Unit	Remote Unit	Remote Unit
Station Type			
Station Rank (1-1000)	1	1	1
Center Frequency	2.4400 GHz	2.4400 GHz	2.4400 GHz
Security Password 1 (Hex)	1	1	1
Security Password 2 (Hex)	10	10	10
Security Password 3 (Hex)	100	100	100
Security Password 4 (Hex)	1000	1000	1000
Security Password 5 (Hex)	10000	10000	10000
Scrambling Code (Hex)	0	0	0
Acquisition Code (0-15)	1	1	1
Config Test Minutes (1-120)	10	10	10
Base Station Only Parameters			
Repeater Mode	off	off	off
System Symmetry Type	Asymmetric	Asymmetric	Asymmetric
Dynamic Polling Level (1-100)			
Remote Station Only Parameters			
Remote Unit RF Group (0-63)	0	0	0
Reboot New RF configuration	Press Enter to Execute		
Save Current Config to Flash	Press Enter to Execute		

- Select **Station Type**. Choose `Base Station`.
 - Select **Station Rank**. Enter the total number of remote units in your wireless network. For example, if you have only one remote unit, enter "1". If there are 20 remote units, enter "20".
 - Select **Center Frequency**. Press the up or down arrow keys to choose the frequency. All units in a wireless network must be set to the same center frequency.
 - Select **Acquisition Code**. Enter a value from 0–15. (All units in the same network must have the same acquisition code.)
 - Select **Security Password 1**. Type a security password in hexadecimal for the unit.
 - Enter the remaining passwords. (All units in the same network must have the same set of five security passwords.)
 - Select **Config Test Minutes**. Enter a time in minutes, for example, 10. The unit will automatically reboot when this time period expires, and uses the settings stored in flash memory instead of current settings.
 - Select **Reboot New RF configuration** and press **Enter**. The unit reboots and the Login window is displayed.
7. Log in to the unit. (Enter `supervisor` for the password). The Main Menu is displayed.
8. Select **Radio Module Configuration** and press **Enter**. The Radio Module Configuration window is displayed.
9. Select **Save Current Config to Flash** and press **Enter**. The new settings are stored in flash memory and displayed on the menu. The word **Success** appears on the screen.
10. Press **Esc** to go back to the Main Menu.
11. Select **Logout** to exit or press **Esc**.

Note: At this time you may want to finish configuring the base station according to the network plan. See [Configuration](#), page 31 for instructions about viewing and changing various settings.

Configuring a Remote Unit

When you configure a unit as a remote unit, you need to perform the following tasks.

- Check the Network Configuration information of the unit
- Set the Station Type of the unit to "Remote Unit"
- Assign the Station Rank (polling ID # of the remote unit)
- Select a Center Frequency (must be the same for all units in network)
- Select an Acquisition Code (must be the same for all units in network)
- Set the security passwords (must be the same for all units in network)
- Change the default menu passwords

These tasks are described below in detail.



To configure a unit as a remote unit

1. Connect a PC to a Hopper Plus remote unit. Connect the COM port of the PC to the MANAGEMENT port of the remote unit using an adapter plug and RS-232 cable. See [Configuring a Base Station](#), page 16 for cabling diagram.
2. Start HyperTerminal® or other terminal emulation program (see [Appendix B: Using HyperTerminal](#), page 121). Use the following communication settings: 9600 bps, 8 bits, no parity, 1 stop bit, no flow control.
3. Press **Enter**. The Hopper Plus Login window is displayed. Type the default password `supervisor` and press **Enter**. The Main Menu is displayed.
4. Select **Network Configuration**. Check the IP settings. If necessary, change the settings to match the network plan.
5. From the Main Menu, select **Radio Module Configuration** and press **Enter**. The Radio Module Configuration window is displayed.

Radio Module Configuration			
	New	Current	Flash
Station Type	-> Remote Unit	Remote Unit	Remote Unit
Station Rank (1-1000)	1	1	1
Center Frequency	2.4400 GHz	2.4400 GHz	2.4400 GHz
Security Password 1 (Hex)	1	1	1
Security Password 2 (Hex)	10	10	10
Security Password 3 (Hex)	100	100	100
Security Password 4 (Hex)	1000	1000	1000
Security Password 5 (Hex)	10000	10000	10000
Scrambling Code (Hex)	0	0	0
Acquisition Code (0-15)	1	1	1
Config Test Minutes (1-120)	10	10	10
Base Station Only Parameters			
Repeater Mode	off	off	off
System Symmetry Type	Asymmetric	Asymmetric	Asymmetric
Dynamic Polling Level (1-100)			
Remote Station Only Parameters			
Remote Unit RF Group (0-63)	0	0	0
Reboot New RF configuration	Press Enter to Execute		
Save Current Config to Flash	Press Enter to Execute		

- **Select Station Type.** Choose Remote Unit.
 - **Select Station Rank.** Enter the rank number of the remote unit. Enter a number from 1–1000.
 - **Select Center Frequency.** Choose a frequency and press **Enter**. Remote units must be set to the same center frequency as the base station.
 - **Select Acquisition Code.** Enter a value from 0–15. (All units in the same network must have the same acquisition code.)
 - **Select Security Password 1.** Type a security password in hexadecimal for the unit.
 - Enter the remaining passwords. (All units in the same network must have the same set of five security passwords.)
 - **Select Remote Unit RF Group.** Enter a value from 0–63. (For testing purposes, you may leave the value = 0.)
6. Select **Config Test Minutes** and press **Enter**. Enter a time in minutes, for example, 10. At the end of this time period, the unit will automatically reboot using the settings stored in flash memory rather than the **Current** settings.
 7. Select **Reboot New RF configuration** and press **Enter**. The unit reboots and the Login window is displayed.
 8. Log in to the unit. (Type **supervisor** for the password). The Main Menu is displayed.
 9. Select **Radio Module Configuration** and press **Enter**. The Radio Module Configuration window is displayed. The settings under **Current** change to values that were in the **New** column.
 10. Select **Save Current Config to Flash** and press **Enter**. The new settings are stored in flash memory and displayed on the menu. The word **Success** appears on the screen.
 11. Press **Esc** to go back to the Main Menu.
 12. Select **Logout** to exit or press **Esc**.

Note: At this time you may want finish configuring the unit according to the network plan. See [Configuration](#), page 31 for instructions about viewing and changing various settings.

Bench Test Units

In this section, you will perform the following tasks.

- Ensure that a basic RF link exists between a base station and a remote unit
- Test the ability of the link to carry test data
- Perform a simple network test

Establishing a Basic RF Link

This test ensures that a basic RF link exists between a base station and a remote unit.

IMPORTANT

The quality of your digital data transmission depends greatly on the quality of your RF link. **Always try to establish a high-quality RF link first.** A high-quality RF link will result in high-quality data transmissions and a low BER. A low-quality RF link will result in low-quality data transmissions and a high bit error rate (BER). Digital data can always be sent across a high-quality RF link. If the RF link is of poor quality, data either cannot be sent at all or will contain too many errors to be useful.

Tip: First configure one unit as a base station, and then use it to test all the remote units.



To establish a basic RF link

1. Ensure that one unit is configured to a base station, select a center frequency and set the test minutes. See [Configuring a Base Station](#), page 16.
2. Ensure that the other unit(s) are configured as remote units and with the center frequency the same as the base station. See [Configuring a Remote Unit](#), page 19.
3. Place the base station and a remote unit at least twenty meters apart with a clear line of sight between antennas.
For directional antennas, point antennas toward each other. For a dipole antenna, orient the antenna vertically.

Basic Test Setup

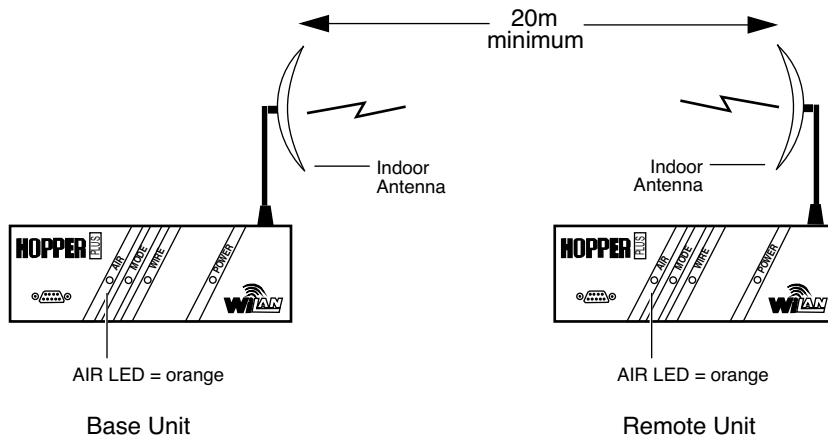

4. Power up the base station. The green POWER LED is ON. The AIR LED of the base unit is red. This AIR LED color indicates that the unit is transmitting data but is not receiving a response. (The reason is that the remote is powered off.)
5. Power up the remote unit. The green POWER LED is ON. The AIR LED of the remote unit turns orange and the AIR LED of the base station also turns orange as both units send and receive data from each other. Orange is the normal AIR LED color.

The color of the AIR LED during this step indicates the following conditions.

Orange (both stations)	Units are continuously sending and receiving sync packets
Red (base station)	Stations are configured incorrectly, and the base station is transmitting without receiving acknowledgment
Green (remote station)	Stations are configured incorrectly, and the remote station is receiving packets to which it cannot respond
Off	Nothing is being received (by the remote) or transmitted (from the base)

Note: If antennas are placed too close together (< 20 m), the strong transmit signal can saturate the receiving unit. Fine-tune antennas by changing antenna orientations until the AIR LED is orange.

Next, you will test the link's basic ability to carry data.

Testing a Basic RF Link

When both the base station and remote unit can receive and transmit data to each other (indicated by orange AIR LEDs on both units), a basic RF link is established. You can now test the link with Link Monitor. Link Monitor tests a link by sending and receiving test data over a link, in both directions, at the same time. For information about testing a link in the receive or transmit direction only, see [Performing Link Monitor Test \(Normal Mode\)](#), page 52.



To test the RF link

1. Connect the test PC to the MANAGEMENT port of the base station or remote unit. See [Connecting PC to MANAGEMENT Port](#), page 16.
2. Log in to the unit and go to the Main Menu.
3. Select **RF Station Configuration** and press **Enter**. The RF Station Configuration window is displayed.

```

RF Station Configuration

Operating Mode                -> Normal Mode
RF Transmit Status            unblocked
Link Monitor Period (0=OFF, 1-10000)  0
Test Mode Timer Minutes (1-1000)    5

Base Station Only Parameters

Maximum Remote Distance        5 Km
Link Monitor Remote Station Rank  1

Remote Station Only Parameters

Throttle Enable                off
Throttle Level (1-50)          1

```

- Select **Operating Mode**. Press the arrow keys to select Normal mode.
- Select **RF Transmit Status**. Select unblocked.
- Select **Link Monitor Remote Station Rank**. Enter the rank of the unit that you want to link test. (The rank is the identification number of the unit. The rank of a remote can be any number from 1 – 1000. The rank number of the the base station is always 0. See [Setting the Station Rank](#), page 67.)
- Select **Link Monitor Period**. Enter a link monitor period of 1. (A value of 1 means that 50% of available data packets will carry test data. The higher the period number, the fewer the number of data packets that will carry test data. See [Setting the Link Monitor Period](#), page 59 for more information.) **The Link Monitor test starts as soon as a non-zero value is entered in the field.**

Next, you will view the link statistics.

- From the Main Menu select **Link Monitor Display** and press **Enter**. The RF Background Link Monitor Statistics window is displayed.

RF Background Link Monitor Statistics	
Link Monitor Rank	1
Base to Remote BER	0.0E+00
Remote to Base BER	0.0E+00
Missed Packet Count	0
Base to Remote Env Power	27
Base to Remote Corr Power	28
Remote to Base Env Power	29
Remote to Base Corr Power	30

- Check for the following statistics.
 - Base to Remote BER = 0.0E+00
 - Remote to Base BER = 0.0E+00
 - Base to Remote Corr Power between 15 – 50 dB
 - Remote to Base Corr Power between 15 – 50 dB

If the Corr Power is <15 dB the receive signal is probably too weak to be useful. If the power is > 55 dB the receiving unit is probably being saturated. If you have problems ensure the unit is configured to its basic default settings (see [Restoring Factory Configurations](#), page 94) and reconfigure the unit, or contact Wi-LAN technical assistance center.
- When you finish viewing link monitor statistics, disable Link Monitor to remove the overhead test data from the wireless link. To disable Link Monitor, select **RF Station Configuration** from the Main Menu and press **Enter**. The RF Station Configuration window is displayed.
- Select **Link Monitor Period** and press **Enter**. The field is highlighted.
- Type 0 in the field and press **Enter**. The link monitor test ends.
- Press **Esc** to exit to Main Menu.

You have now established an RF link between two units and tested the ability of the link to carry some test data. Next, you connect the units to a simple network and perform some tests.

Performing Simple Network Tests

To test units within a simple network you require two Hopper Plus 120-24 units, a LAN connection, a PC and a crossover ethernet cable or hub connection.

To perform a simple network test

- Connect the 10/100BaseT port of the remote unit to the wired LAN.

10/100BASET Connection

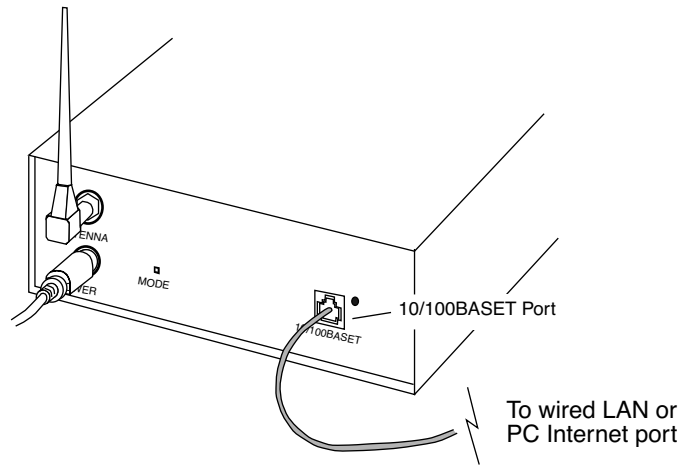

2. Connect the 10/100BaseT port of the base station to the internet port of the PC. You can either connect to a network hub or connect directly using an RJ45 crossover ethernet cable.

Simple Network Test Setup

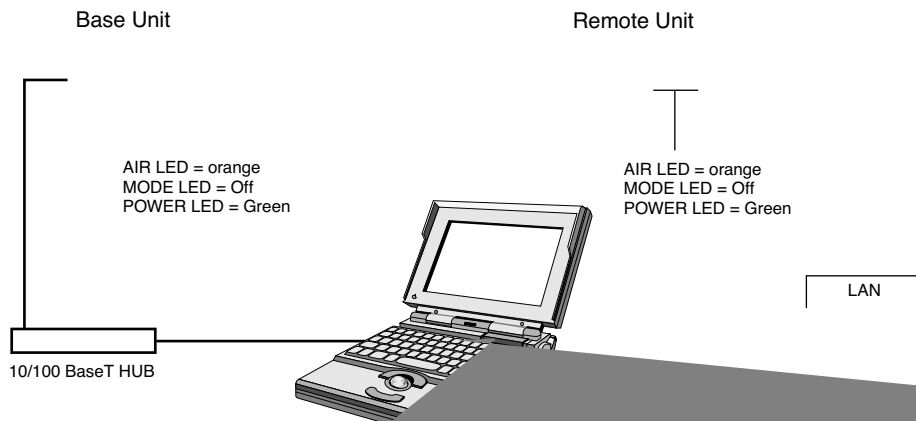

3. Power up both Hopper Plus units. I

PC

- Configure the Hopper Plus units within your network. See [Network Configuration](#), page 40 for information about Hopper Plus Internet addresses. See [Appendix C: Configuring a Simple Data Network](#), page 127 for information about configuring simple peer-to-peer networks.
- Create some network traffic to test the wireless link. For example, use **ping** or **ftp put** and **get** to transfer a large test files, in both directions, across the link. The WIRE LED on the Hopper Plus indicates link file transfer activity to the wired LAN. When the file transfer is done, **ftp** displays the size of the file and the time it took to transfer the file. This information can be used to measure the data throughput of the wireless link, and is very useful for troubleshooting.

Using ping and ftp

ping

From the command line prompt, type:

```
C:> ping IP Address
```

Example:

```
ping 192.163.2.88
```

ftp

To connect to the node, from the DOS prompt, type:

```
C:> ftp IP Address
```

For instructions about using ftp, type "help" at the ftp prompt.

```
ftp> help
```

Follow the instructions.

- Test all units in the network.

Install Units

This section provides some guidelines about installing units in the field.

- Install the units at locations identified in the network plan. Some units will simply sit on a table or desk and do not require any special antenna work. Other units must be installed inside communication cabinets or racks and will require professional antenna installation.

WARNING

Outdoor antennas must be professionally installed following accepted safety, grounding, electrical, and civil engineering standards. An antenna (indoor or outdoor) must be connected to the ANTENNA port of a unit before a unit is powered up to avoid damaging the unit.

- Verify that there is no interference at the site by performing spectrum sweeps with a spectrum analyzer. Perform sweeps at various times of the day (for example, 9AM, noon, and 3 PM are peak telephone traffic times.) If there are problems, contact the network planner, who may need to change the system configuration or design.
- Sweep antennas and cables with the Site Master[®] communications test set, before securing antennas and cables to towers, while they are on the ground and easy to access. Sweeping helps to ensure that antennas and cables will operate as expected.
- Initially install equipment with flexibility—do not tie down cables, antennas should be free to move, allow some slack in cables, avoid drilling and do not seal connections.
- Align antennas. (Two people are required, one at the base station and one at the remote unit. When in the field, you may require binoculars and 2-way radios to communicate.) When aligning antennas, adjust the orientation of the remote antenna while running a link monitor test between the remote and the base station. Adjust the antenna until you achieve the highest fade margin with no bit errors (BER = 0). See [Performing the RSSI Test](#), page 57 and [Performing Link Monitor Test \(Normal Mode\)](#), page 52 for instructions. Repeat the antenna alignment procedure for each remote.
- When antennas are aligned and cables are secured, sweep the antennas with the Site Master test set a final time before connecting to Hopper Plus.
- Perform diagnostic tests on the installed system. Compare field results to bench test results using ping, ftp, fade margins, etc. Document your results (these results will be very useful when troubleshooting and monitoring the system's performance).
- When the system works as specified in the network plan, lock down and weatherproof all equipment and connections.

Point-to-Multipoint Installation

The procedure for installing a point-to-multipoint system is the same as the procedure for installing a point-to-point system. Treat each link in a point-to-multipoint system as a single, point-to-point wireless link.

Co-Location Installation

When you install a system with sectors and co-located base stations (see [Creating a Network with Cells](#), page 5 for an example), you install and test sectors as if they were point-to-point systems; however, in this case you must ensure that individual sectors are not interfering with each other.

- Align and test the first sector. Measure the fade margin and run the link monitor test. Document your results, then turn off the radio in the first sector.
- Align and test the second sector. Measure the fade margin and run the link monitor test. Leave the link monitor test running in the second sector.
- Turn on the radio in the first sector again and run the continuous transmit test. See [Performing Transmit and Receive Tests](#), page 55.
- Observe the BER and fade margin of the second sector radio. Look for changes to determine if the first sector is interfering with the second sector.
- Repeat the tests for all sector/pair combinations.

Test Network

Run the link monitor test, transmit test and network tests such as ping and ftp file transfers to verify operation when the units are installed in the field. See [Performing Link Monitor Test \(Normal Mode\)](#), page 52.

Adding to a Network

Always add to your network one link or device at a time, working from a known base network. Measure and document changes to the system and changes in performance. For example, you can transfer files with **ftp** and measure the performance with a tool such as NetXray®. The key to a successful network is to proceed one step at a time and to understand your network!

Network Test Setup

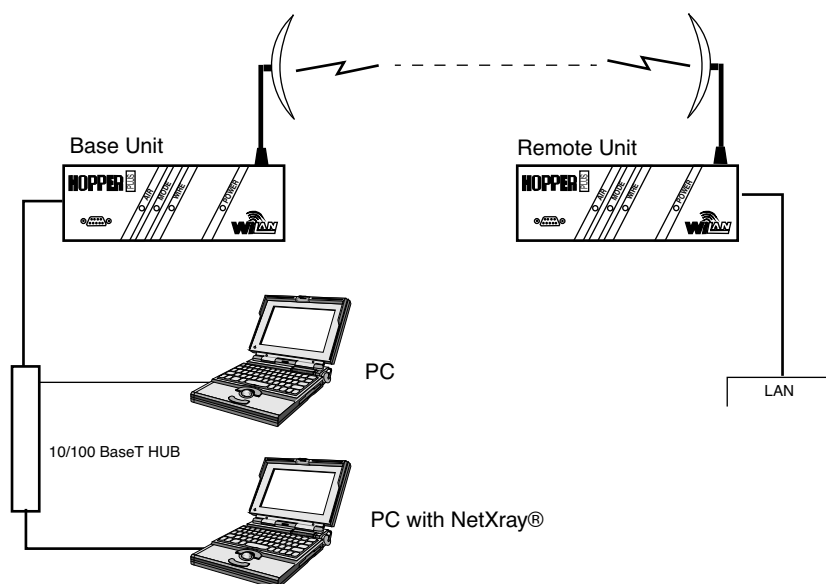

Preventative Maintenance and Monitoring

You should set up a preventative maintenance schedule for your network. Wi-LAN recommends that the following preventative maintenance be performed at least semi-annually.

- Regularly run link monitor tests across the network and measure BER and fade margin. You can also test the network with ping, ftp and file transfers. Other resources are available on the Internet that can help you monitor the performance of your link, for example see www.globalcast.se.
- If you have SNMP application software, you can check unit operation from a remote location. See [Appendix D: SNMP](#), page 133 for more information.

You should periodically perform a physical inspection of each site.

- Check that antennas and cables are secure and have not become loose.
- Check for physical obstructions in the line-of-sight radio path, such as trees and buildings.
- Sweep antennas and cables to ensure that antennas and cables are intact and operating properly.
- Check that there are no water leaks in cabinets.
- Check weatherproofing.
- Check for new sources of electromagnetic interference.

Configuration

Overview

This section explains how to use the Main Menu to configure and test your Hopper Plus unit, and to obtain useful statistical and maintenance information.

Main Menu

In this section, each item in the Main Menu is described in the order that it appears in the menu. See [Appendix F: Menu Map](#), page 149 for a complete listing of submenus. Use the Main Menu and your keyboard keys to select, view or change settings. Some items in the menu simply display information, while others ask you to enter data or make a selection from a list.

Main Menu

```
Wi-LAN Hopper Plus 120-24 Main Menu
```

```
-> Unit Identification  
    Hardware/Software Revision  
    System Software ROM Images  
    Current System Status  
    Network Configuration  
    IP Filter Configuration  
    RF Station Configuration  
    Radio Module Configuration  
    RF/Ethernet Statistics  
    System Security  
    System Commands  
    Link Monitor Display
```

```
Logout
```

Accessing the Main Menu

You can access the Main Menu of a Hopper Plus unit with a HyperTerminal® session (via the MANAGEMENT port) **or** a *telnet* session. Most instructions provided in this chapter assume that you have opened a HyperTerminal session.

You can also configure the Hopper Plus 120-24 remotely with the SNMP (Simple Network Management Protocol). See [Appendix D: SNMP](#), page 133 for information about SNMP.

Accessing the Main Menu with HyperTerminal®

To access the Main Menu with HyperTerminal

1. Disconnect power from the Hopper Plus unit.
2. Connect a serial cable from a DB9 serial port on the PC to the MANAGEMENT port on the Hopper Plus. See [Configuring a Base Station](#), page 16.
3. Start Hyperterminal or another terminal emulation program on the PC. See [Appendix B: Using HyperTerminal](#).
4. Set the terminal emulation program to emulate a VT100 terminal with the following settings.
 - COM port PC serial port connected to Hopper Plus unit
 - Bits per second: 9600
 - Data bits: 8
 - Parity: none
 - Stop bits: 1
 - Flow control: none
5. Reconnect the power to the Hopper Plus unit.
6. Press **Enter**. The Wi-LAN Hopper Plus 120-24 Login menu is displayed.

```

Wi-LAN Hopper Plus 120-24 Login

Software:  Rev 0.0.0 (May 25 2000 10:13:37)
Hardware:  Rev 0.0.0 (4MB SDRAM, 4MB Intel Flash)

Enter Password:

```

7. Type a default password (`user` or `supervisor`) or type your personal password if already have one.

Login Account	Default Password	Privileges
User	user	Read Only
Supervisor	supervisor	Read and Write

The Main Menu is displayed.

Accessing Units via telnet

To access units via telnet

1. Ensure that the unit's Internet IP address has been configured, the unit has a working Ethernet connection, and wire and remote access has been enabled (see [Allowing Remote Access and Configuration](#), page 89).
2. Ensure that the VT100 Arrows feature in your telnet session is enabled. See [Setting VT100 Arrows](#), page 33.
3. From the DOS prompt, type
`C:>telnet <IP address>`
 where <IP address> is the IP address of the unit that you want to configure.
4. Press **Enter**. The Login menu is displayed.

```

Wi-LAN Hopper Plus 120-24 Login

Software:   Rev 0.0.0 (May 25 2000 10:13:37)
Hardware:   Rev 0.0.0 (4MB SDRAM, 4MB Intel Flash)

Enter Password:
  
```

5. Type the default password (`user` or `supervisor`) or type your personal password. The Main Menu is displayed.

Setting VT100 Arrows

To set the VT100 arrows in Microsoft telnet

1. In the active Microsoft telnet I.O session, select **Terminal, Preferences** from the menu bar. The Terminal Preferences window is displayed.

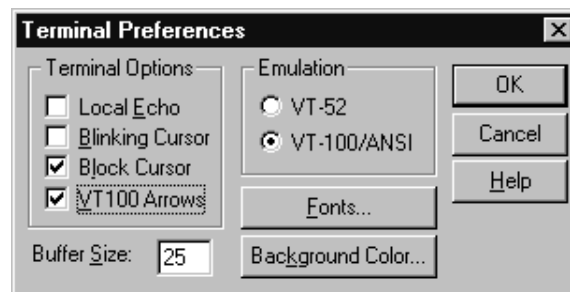

2. Click the **VT100 Arrows** checkbox.
3. Click **OK**. The VT100 arrows are enabled in the telnet session.

You can now use the keyboard arrow keys to navigate the configuration menus.

Configuring with the Main Menu

This section describes how to configure units with the Main Menu. Menu items are presented in the order they appear in the menu shown below.







Main Menu

```
Wi-LAN Hopper Plus 120-24 Main Menu

-> Unit Identification
   Hardware/Software Revision
   System Software ROM Images
   Current System Status
   Network Configuration
   IP Filter Configuration
   RF Station Configuration
   Radio Module Configuration
   RF/Ethernet Statistics
   System Security
   System Commands
   Link Monitor Display

Logout
```

How to Use the Main Menu

- To select an item from the Main Menu or a sub-menu, press the keyboard arrow keys   to move the cursor -> next to the item.
Press the Enter key  to open the data entry field.
- To scroll through items in the data entry field, press   .
Press  to select an item from the field.
- To exit from a menu, press the **Esc** key. 

Unit Identification

Viewing Unit Identification

You can view a unit's serial number, production date, and MAC address with the Unit Identification menu. The fields are view only and are set at the factory.

You can also view the Unit Name/Description, Unit Location, and Contact Name. These fields are optional and can be changed.

To view unit identification information

- I. From the Main Menu, select **Unit Identification** and press **Enter**. The Unit Identification menu is displayed.

```

                                Unit Identification

Serial Number                    Serial-Number
Production Date                  Jun 07 2000
Ethernet MAC Address             001030000000

Unit Name/Description            -> System Name
Unit Location                    System Location
Contact Name                     System Manager's Name

```

Serial Number	Unique serial number of unit (Read Only)
Production Date	Date unit was produced (Read Only)
Ethernet MAC Address	Unique Internet MAC (Media Access Control) address of the unit (Read Only)
Unit Name/Description	Name of unit (optional)
Unit Location	Location of unit (optional)
Contact Name	Name of contact person (optional)

Assigning Unit Identification Information

You can assign a name, location and contact name to units. This information will help you to distinguish units by physical location or by meaningful names rather than station rank only. Unit identification information is optional.

▶ To assign or change unit identification information

1. From the Main Menu, select **Unit Identification** and press **Enter**. The Unit Identification menu is displayed.

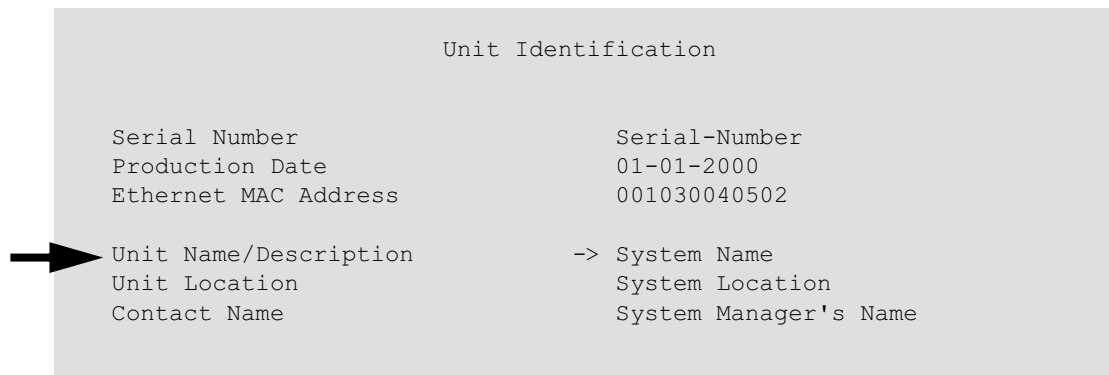

2. Select **Unit Name/Description** and press **Enter**. The data field highlights.
3. Type in a new name or description.
4. Press **Enter**. The new name or description is displayed in the data field.
5. Select **Unit Location** and press **Enter**. The data field highlights.
6. Type the location of the unit.
7. Press **Enter**. The new location appears in the data field.
8. Select **Contact Name** and press **Enter**. The data field highlights.
9. Type a contact or manager name.
10. Press **Enter**. The new name appears in the entry field.
11. Press **Esc** to exit to the Main Menu.

Hardware/Software Revision

Viewing System Revision Information

The System Revision Information window shows the revision information of the unit including memory revision number, memory size and software revision number.

▶ To view system revision information

1. From the Main Menu, select **Hardware/Software Revision** and press **Enter**. The System Revision Information window is displayed. The menu is view only.

```

System Revision Information

Hardware      Rev 0.0.0 (4MB SDRAM, 4MB Intel Flash)
ROM Size     0x400000
RAM Size     0x400000

Software      Rev 0.0.0 (Wi-LAN Hopper Plus 120-24 WEBII)
              June 26 2000 10:13:37
              318452 Bytes
File Name     FACTORY-IMAGE
  
```

Hardware	Revision number of the unit, the amount SDRAM and FLASH memory available in the unit
ROM Size	Amount of Flash read-only memory in the unit = 4 MB
RAM Size	Amount of random-access memory in the unit = 4MB
Software	Revision number of the system image running on the unit, the date of the revision, and the size of the image file (in this example FACTORY-IMAGE is about 318 Kbytes)
File Name	File name of the system image running on the unit

2. Press **Esc** to exit to the Main Menu.

System Software ROM Images

Viewing System Software ROM Images

A ROM image is the software that a unit uses to operate. The System Software ROM Images window lists software images currently available in the unit. New images can be loaded into a unit's Flash ROM from an outside source such as a PC or EPROMs inside the unit that contain the software can be replaced. The example below shows that only the "Factory-Image" is available, however, in the future other images may be available. If required, you can obtain a new image file from Wi-LAN Technical Assistance Center and download it to your Hopper unit—see [Appendix G: Upgrading Software](#), page 151 for instructions. See [Setting Default System Image](#), page 92 for instructions about selecting a default image.

▶ **To view system software ROM images**

1. From the Main Menu, select **System Software ROM Images** and press **Enter**. The System Software ROM Images window is displayed. The window is view only.

System Software ROM Images						
File Name	Revision	Date	Time	Size	Default Image	
FACTORY-IMAGE	0.0.0	Aug 24 2000	10:13:37	306524	Current	

File Name	Name(s) of system image file(s) stored in the unit. To add or delete images you must use ftp. See Appendix G: Upgrading Software , page 151
Revision	Revision number of the system image file. Each time the system image is modified, the revision number increases by 1 unit. For example, the first revision to the file would make the revision number 0.0.1
Date	Date image file was last revised
Time	Time image file was last revised
Size	Size of image file in bytes
Default Image	Indicates which image file is the default. Default Image is used at power up. See Setting Default System Image , page 92 to modify default image

2. Press **Esc** to exit to the Main Menu.

System Current Status

Viewing System Current Status

The System Current Status window provides administration information such as the amount of time a unit has been running and login statistics.

► To view system current status

1. From the Main Menu, select **System Current Status** and press **Enter**. The System Current Status window is displayed. The window is view only.

```

System Current Status

Cumulative Run-Time          Days: 0      Hours: 7
Current Run-Time            Days: 0    00:38:38
Successful Logins           16
Unsuccessful Logins         1
Local User Logged In       Supervisor
Telnet User Logged In      None
FTP User Logged In         None

```

Cumulative Run-Time	Number of hours the system has been running since it was manufactured—information is required for maintenance purposes
Current Run-Time	Time duration since the unit was last reset or power cycled
Successful Logins	Number of times the configuration menus have been successfully accessed
Unsuccessful Logins	Number of times access to the configuration menus has failed
Local User Logged In	Access level of user currently logged into the configuration menus via the RS-232
Telnet User Logged In	Access level of user currently logged into the configuration menus via a telnet session
FTP User Logged In	Access level of user currently logged into the host FTP server

2. Press **Esc** to exit to the Main Menu.

Network Configuration

Each Hopper Plus 120-24 unit in a system must have a valid Internet IP address and subnet mask to communicate via TCP/IP. You will need to know this information to remotely manage units. Your system administrator should be able to supply you with this information.

Viewing Internet IP Addresses and Subnet Mask

► To view the Internet IP addresses and subnet mask

1. From the Main Menu, select **Network Configuration** and press **Enter**. The Network Configuration menu is displayed.

```

Network Configuration

Internet IP Address                192.168.1.100
New IP Address (Reboot Req'd)    -> 192.168.1.100
Internet IP Subnet Mask          255.255.255.0
Default Gateway IP Address       0.0.0.0
SNMP NMS Trap IP Address        0.0.0.0
MAC Filter Entry Age Time Minutes (1-60) 5
    
```

Internet IP Address	IP address of unit
New Internet IP Address (Reboot Req'd)	New IP address of unit. Required when changing IP address
Internet IP Subnet Mask	Number that is used to determine if a node is part of LAN or whether a transmission must be handled by router (the subnet mask is logically ANDed with the IP address)
Default Gateway IP Address	Address of main entry point into the network
SNMP NMS Trap IP Address	NMS (network management system) trap address Collects alarms and events and passes them to the network administrator
MAC Filter Entry Age Time Minutes	Number of minutes after which the MAC (Media Access Control) filter entry will expire

2. Press **Esc** to exit to the Main Menu.

Setting the Internet IP Address

▶ To set the new Internet IP address

1. From the Main Menu, select **IP Network Configuration** and press **Enter**. The Network Configuration menu is displayed.

```

Network Configuration

Internet IP Address                192.168.1.100

▶ New IP Address (Reboot Req'd)    -> 192.168.1.100
Internet IP Subnet Mask            255.255.255.0
Default Gateway IP Address         0.0.0.0
SNMP NMS Trap IP Address          0.0.0.0
MAC Filter Entry Age Time Minutes (1-60) 5

```

2. Select **New IP Address** and press **Enter**. The data field highlights.
3. Type the unique Internet IP address for the unit.
4. Press the **Enter** key. The new Internet IP address appears in the **New IP Address (Reboot Req'd)** field, but the old address remains in the Internet IP Address field.
5. To save the changes, reboot the unit or power the unit down and up.
6. Press **Esc** to exit to the Main Menu.

Setting the IP Subnet Mask

▶ To set the default IP subnet address

1. From the Network Configuration menu, select **Internet IP Subnet Mask** and press **Enter**. The data field highlights.
2. Type the Internet IP subnet mask for the unit.
3. Press **Enter**. The Internet IP subnet mask appears in the field and is assigned to the unit.
4. Press **Esc** to exit to the Main Menu.

Setting the Default Gateway IP Address (future)

You can define the IP address of the system gateway. This address designates the main entry point into the network and is usually in the same subnetwork as the unit IP address.

To set the default gateway IP address

1. From the Network Configuration menu, select **Network Configuration**. The Network Configuration menu is displayed.
2. Select **Default Gateway IP Address** and press **Enter**. The data field highlights.
3. Type the default gateway IP address for the unit.
4. Press **Enter**. The default gateway IP address for the unit appears in the field.
5. Press **Esc** to exit to the Main Menu.

Setting the SNMP NMS Trap IP Address (future)

The SNMP (System Network Management Protocol) NMS (Network Management System) Trap IP address identifies the IP address of the network manager. This address passes alarms or events from the unit to the network manager. The network manager can define the types of traps or alarms that will be forwarded to the IP address.

To set the SNMP NMS trap IP address

1. From the Network Configuration menu, select **SNMP NMS Trap IP Address** and press **Enter**. The data field highlights.
2. Type the SNMP NMS Trap IP address for the unit.
3. Press **Enter**. The SNMP NMS Trap IP address appears in the entry field and is applied to the unit.
4. Press **Esc** to exit to the Main Menu.

Setting the MAC Filter Entry Age Time Minutes

The MAC Filter Entry Age Time Minutes setting enables you to control the number of minutes after which the MAC (Media Access Control) filter will expire. This feature enables you to set the MAC time period of a unit to a value that is most compatible with the MAC time period of other devices on a network.

To set the MAC Filter minutes

1. From the Network Configuration menu, select **MAC Filter Entry Age Time Minutes** and press **Enter**. The data field highlights.
2. Type a value from 1–60 and press **Enter**. The number of minutes appears in the entry field and is applied to the unit.
3. Press **Esc** to exit to the Main Menu.

IP Filter Configuration

Two different IP filters are available: a packet filter, and an address filter. The IP packet filter determines which type of packets are allowed to pass through a unit. If the IP Packet Filter is OFF, the unit passes all packets. If the IP Packet Filter is ON, the unit passes only IP and ARP (Address Resolution Protocol) packets.

IP address filters are actually tables containing sets of IP addresses. When IP address filtering is enabled, all IP packet are sorted according to the following conditions:

1. If the **source** IP address is contained in one of the IP address lists, IP packets coming from the wire will be forwarded to the air. If not, IP packets are dropped.
2. If the **destination** IP address is contained in one of the IP address lists, IP packets coming from the air will be forwarded to the wire. If not, IP packets are dropped.

Each IP address filter is defined by a range and base value. IP address filtering improves system security and helps manage data throughput.

Viewing IP Filter Configuration



To view current IP filter configuration

1. From the Main Menu, select **IP Filter Configuration** and press **Enter**. The IP Filter Configuration menu is displayed.

```

IP Filter Configuration

IP Packet Filtering      -> off
IP Address Filtering     off

Filter 1 Range (0-255)   0
Filter 1 Base Address    0.0.0.0

Filter 2 Range (0-255)   0
Filter 2 Base Address    0.0.0.0

Filter 3 Range (0-255)   0
Filter 3 Base Address    0.0.0.0

Filter 4 Range (0-255)   0
Filter 4 Base Address    0.0.0.0

Filter 5 Range (0-255)   0
Filter 5 Base Address    0.0.0.0

```

IP Packet Filtering	off (disabled)	All packets are passed
	on (enabled)	Only IP (Internet Protocol) packets and ARP packets can pass
IP Address Filtering	off (disabled)	Packets from all IP addresses pass
	on (enabled)	Only packets whose IP addresses listed in at least one IP filter pass. Up to five IP filters are available; each filter lists up to 255 IP addresses
Filter n Range	n = 0–5	Defines how many contiguous IP addresses are in the filter's list of addresses
Filter n Base Address	n = lowest IP Address	Lowest numbered address on the filter's list of IP addresses

The following is an example of an IP Filter.

Example: IP Filter

```

IP Packet Filtering = on
IP Address Filtering = on
Filter 1 Range (0 - 255) = 4
Filter 1 Base Address = 192.168.2.10
Filter 2 Range (0 - 255) = 2
Filter 2 Base Address = 194.120.3.51
Filter 3 Range (0 - 255) = 4
Filter 3 Base Address = 194.120.3.254
    
```

Enabling IP Packet Filtering

IP Packet filtering should initially be set to **off** so you can start from a known state and observe changes that result from using the IP packet filter.

▶ To enable IP packet filtering

1. From the IP Filter Configuration menu, select **IP Packet Filtering** and press **Enter**. The data field highlights.

```

IP Filter Configuration
  IP Packet Filtering      -> off
  IP Address Filtering     off

  Filter 1 Range (0-255)  0
  Filter 1 Base Address   0.0.0.0

  Filter 2 Range (0-255)  0
  Filter 2 Base Address   0.0.0.0

  Filter 3 Range (0-255)  0
  Filter 3 Base Address   0.0.0.0

  Filter 4 Range (0-255)  0
  Filter 4 Base Address   0.0.0.0

  Filter 5 Range (0-255)  0
  Filter 5 Base Address   0.0.0.0

```

2. Scroll to **on**.
3. Press **Enter** to make the change.
4. Press **Esc** to exit to the Main Menu.

Enabling IP Address Filtering

▶ To enable IP address filtering

1. From the IP Filter Configuration menu, select **IP Address Filtering** and press **Enter**. The data field highlights.
2. Scroll to **on** and press **Enter**.
3. Press **Esc** to exit to the Main Menu.

Setting IP Address Filter Range

▶ To set IP address filter range

1. From the IP Filter Configuration menu, select **Filter 1 Range (0 - 255)** and press **Enter**. The data field highlights.
2. Type in the number of contiguous addresses in the filter list (0 - 255) and press **Enter**.
3. Press **Esc** to exit to the Main Menu.

Setting the IP Filter Base Address

▶ To set IP filter base address

1. From the IP Filter Configuration menu, select **Filter 1 Base Address** and press **Enter**. The data field highlights.
2. Type the IP address and press **Enter**. The data field highlights.

Some sample IP base addresses are shown below.

Addresses that pass only IP packets and IP Addresses

192.168.2.10	194.120.3.51	194.120.3.254
192.168.2.11	194.120.3.52	194.120.3.255
192.168.2.11		194.120.4.0
192.168.2.12		194.120.4.1
192.168.2.13		

3. Press **Esc** to exit to the Main Menu.

RF Station Configuration

The RF Station Configuration menu enables you to choose the operating mode, run some tests and optimize the RF link. Four tests can be run from this menu: link monitor test, transmit test, receive test and RSSI test. You can optimize a link by setting the maximum remote distance to a remote and by controlling the rate of data throughput (throttling). You can also block a unit so that it cannot pass any data.

Viewing Current RF Station Configuration

► To view the current RF station configuration

- I. From the Main Menu, select **RF Station Configuration** and press **Enter**. The RF Station Configuration menu is displayed.

```

RF Station Configuration

Operating Mode                -> Normal Mode
RF Transmit Status            unblocked
Link Monitor Period (0=OFF, 1-10000)  0
Test Mode Timer Minutes (1-1000)    5

Base Station Only Parameters

Maximum Remote Distance       5 Km
Link Monitor Remote Station Rank  1

Remote Station Only Parameters
Throttle Enable               off
Throttle Level (1-50)        1

```

Operating Mode	Four modes are available: Normal Mode, Receive Test, Transmit Test, and RSSI Test
RF Transmit Status	Determines if data transmissions through the unit will be blocked or passed
Link Monitor Period	Period determines the amount of test data that is used to test the link. The smaller the number, the larger the amount of test data and test data overhead. A non-zero value starts the link monitor test
Test Mode Timer Minutes	Maximum time in minutes that a unit will be allowed to stay in test mode
Maximum Remote Distance	Distance value compensates for polling delay due to large distances
Link Monitor Remote Station Rank	Rank (or ID number) of the remote that you want to test

Throttle Enable	Turns throttling (data throughput control) on or off
Throttle Level	Determines the data rate of a remote unit. When throttling is enabled, the data rate passed is equal to the throttling level times 128 kbps

2. Press **Esc** to exit to the Main Menu.

Setting the Operating Mode

Four modes are available: Normal Mode, Receive Test, Transmit Test, and RSSI Test.

Normal Mode	Normal operating mode of a unit. Unit transmits and receives data in both directions across the RF link. Link Monitor test is run with the unit set to Normal mode. (You can view the link statistics with Link Monitor Display.)
Receive Test	Receives test data only. Processes expected packet data and displays statistics on RS-232 monitor. Use this mode to test a unit's ability to receive data.
Transmit Test	Transmits test data only. Sends known packet data to the receiving unit. Use this mode to test a unit's ability to transmit data.
RSSI Test	RSSI (Received Signal Strength Indicator) test—indicates signal strength. Unit receives known data packets and displays fade margin data on the AIR LED. Use this mode to get a quick visual indication of the signal strength. See Performing the RSSI Test , page 57 for more information.

▶ To set the operating mode

1. From the Main Menu, select **RF Station Configuration** and press **Enter**. The RF Station Configuration menu is displayed.

```

RF Station Configuration
Operating Mode                -> Normal Mode
RF Transmit Status            unblocked
Link Monitor Period (0=OFF, 1-10000) 0
Test Mode Timer Minutes (1-1000) 5

Base Station Only Parameters

Maximum Remote Distance       5 Km
Link Monitor Remote Station Rank 1

Remote Station Only Parameters
Throttle Enable                off
Throttle Level (1-50)         1

```

2. Select **Operating Mode** and press **Enter**. The data field highlights.
3. Press the arrow keys to select the desired mode: Normal mode, Transmit mode, Receive mode, or RSSI mode.
4. Press **Enter**. The screen clears, and the MODE LED on the unit is ON. The color of the MODE LED indicates the current mode: Normal Mode = off, Transmit Test = red, Receive Test = green and RSSI Test = orange.

- To exit a mode, briefly disconnect the power **or** press and hold the MODE button on the rear panel of the unit. The MODE LED goes off (Normal mode) and the Login menu is displayed.

Note: The operating mode can also be set with the MODE button on the back of the Hopper Plus. See [Setting Operating Mode with the MODE Button](#), page 97 for more information.

General Equipment Setup for Performing RF Tests

The general equipment setup is shown below. The specific setup depends on the test you want to run.

- To perform the Normal Mode (Link Monitor) test you need to connect a PC to either the base station or a remote unit.
- To perform the Transmit Test or Receive Test you need at least one base station with PC, a remote station with PC, and an RF link between units. See [Establishing a Basic RF Link](#), page 21 for instructions about establishing an RF link.
- To perform the RSSI test you need a PC for the unit that will transmit. The receiving unit does not require a PC. You can also run this test with the MODE button.

General Equipment Setup

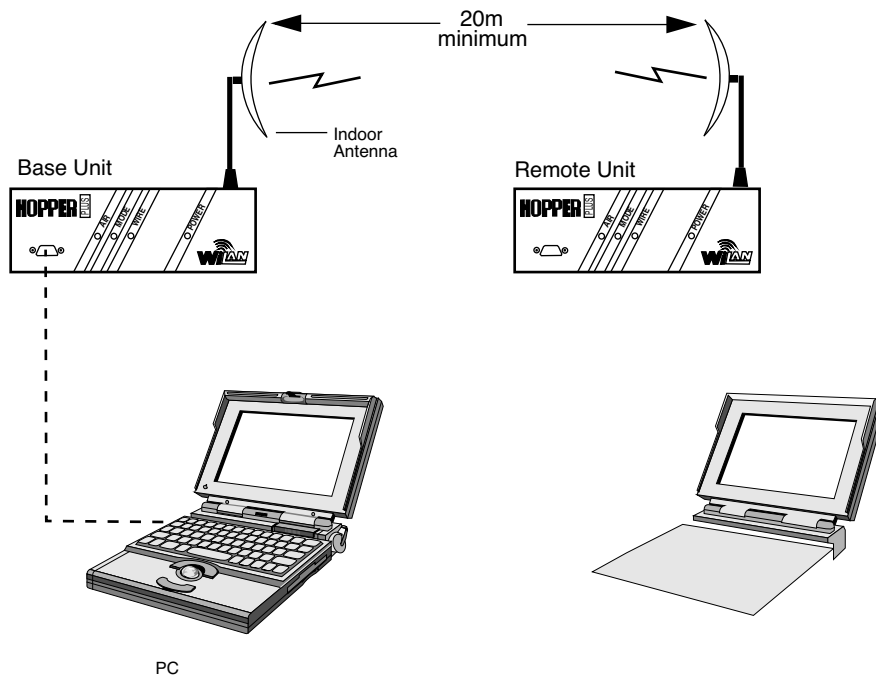

Before you run any tests, you should set the number of test minutes, as described below in [Setting Test Mode Timer Minutes](#), page 51.

Setting Test Mode Timer Minutes

Before you run any of these tests, you should set the maximum time, in minutes, that a unit will be allowed to stay in test mode. When this time period expires, the Hopper Plus unit performs an automatic software reboot and returns to Normal mode. (Test mode timer minutes setting applies only to Transmit Test, Receive Test, and RSSI Test modes.)

Note: The test mode timer minutes can be changed only with this menu. This time period does not apply to Normal mode or the Link Monitor test. See [Setting Operating Mode with the MODE Button](#), page 97.

▶ To set test mode timer minutes

1. From the Main Menu, select **RF Station Configuration** and press **Enter**. The RF Station Configuration menu is displayed.

```

RF Station Configuration

Operating Mode                Normal Mode
RF Transmit Status            unblocked
Link Monitor Period (0=OFF, 1-10000)  0
▶ Test Mode Timer Minutes (1-1000)  -> 10

Base Station Only Parameters

Maximum Remote Distance       5 Km
Link Monitor Remote Station Rank  1

Remote Station Only Parameters
Throttle Enable               off
Throttle Level (1-50)         1

```

2. Select **Test Mode Timer Minutes** and press **Enter**. The data field highlights.
3. Type the desired time in minutes (1-1000). (10 minutes is a suggested starting value.)
4. Press **Enter**.
5. Press **Esc** to exit to the Main Menu.

Performing Link Monitor Test (Normal Mode)

The link monitor test can be run from either a base station or a remote unit that is set to Normal Mode. The test operates in parallel with the message stream, so it consumes some of the link's total data capacity. You can control the ratio of test data to message data (and thereby control the amount of test data overhead) by setting the link monitor period. See [Setting the Link Monitor Period](#), page 59 for more information.

Note: Link monitor test stays in effect even if you power cycle or reboot units, so you must turn it off using the Link Monitor Period (0 = OFF) setting.

▶ To perform Link Monitor test from a base station

1. Connect the test PC to the MANAGEMENT port of the base station. See [General Equipment Setup for Performing RF Tests](#), page 50.
2. Log in to the unit and go to the Main Menu.
3. Select **RF Station Configuration** and press **Enter**. The RF Station Configuration menu is displayed.

```

RF Station Configuration
  Operating Mode                -> Normal Mode
  RF Transmit Status           unblocked
  Link Monitor Period (0=OFF, 1-10000)  0
  Test Mode Timer Minutes (1-1000)    5

Base Station Only Parameters

  Maximum Remote Distance       5 Km
  Link Monitor Remote Station Rank  1

Remote Station Only Parameters
  Throttle Enable               off
  Throttle Level (1-50)         1

```

4. Select **Operating Mode** and press **Enter**. The data field highlights.
5. Press the arrow keys to select **Normal mode** and press **Enter**.
6. Select **RF Transmit Status** and press **Enter**. The data field highlights.
7. Press the arrow keys to select **unblocked** and press **Enter**.
8. Select **Link Monitor Remote Station Rank** and press **Enter**. The data field highlights.
9. Type the rank of the remote unit that you want to link to and press **Enter**. (The rank is the identification number of the remote unit. The rank of a remote can be any number from 1 – 1000. See [Setting the Station Rank](#), page 67.)
10. Select **Link Monitor Period** and press **Enter**. The data field highlights.
11. Type a link monitor period (1) and press **Enter**. Link Monitor starts as soon as a non-zero value is entered in the field. (A setting of 1 means that 50% of all data is test data.)

12. View the link statistics. From the Main Menu select **Link Monitor Display** and press **Enter**. The RF Link Monitor Statistics window is displayed.

RF Link Monitor Statistics	
Link Monitor Rank	1
Base to Remote BER	0.0E+00
Remote to Base BER	0.0E+00
Missed Packet Count	0
Base to Remote Env Power	27
Base to Remote Corr Power	28
Remote to Base Env Power	29
Remote to Base Corr Power	30

13. Check for BER = 0.0E+00 and Corr Power between 15 – 50 dB. If the Corr Power is <15 dB the receive signal is probably too weak. If the power is >55 dB the receiving unit is probably saturated. See [Viewing Link Monitor Statistics](#), page 96 for more information about Link Monitor Statistics.
- If you have problems, ensure that the unit is configured to its basic default settings (see [Restoring Factory Configurations](#), page 94) and reconfigure the unit, or contact Wi-LAN Technical Assistance Center.
14. When finished viewing link monitor statistics, disable Link Monitor to remove the test overhead data from the RF link. Select **RF Station Configuration** from the Main Menu and press **Enter**. The RF Station Configuration menu is displayed.
15. Select **Link Monitor Period** and press **Enter**. The field is highlighted.
16. Type 0 in the field and press **Enter**. The link monitor test ends.
17. Press **Esc** to exit.

To perform Link Monitor test from a remote unit

1. Connect the test PC to the MANAGEMENT port of the remote unit. See [General Equipment Setup for Performing RF Tests](#), page 50.
2. Log in to the unit and go to the Main Menu.

3. Select **RF Station Configuration** and press **Enter**. The RF Station Configuration menu is displayed.

```

RF Station Configuration

-> Operating Mode                -> Normal Mode
RF Transmit Status             unblocked
Link Monitor Period (0=OFF, 1-10000) 0
Test Mode Timer Minutes (1-1000) 5

Base Station Only Parameters

Maximum Remote Distance        5 Km
Link Monitor Remote Station Rank 1

Remote Station Only Parameters
Throttle Enable                off
Throttle Level (1-50)         1
    
```

4. Select **Operating Mode** and press **Enter**. The data field highlights.
5. Press the arrow keys to select **Normal** mode and press **Enter**.
6. Select **RF Transmit Status** and press **Enter**. The data field highlights.
7. Press the arrow keys to select **unblocked** and press **Enter**.
8. Select **Link Monitor Remote Station Rank** and press **Enter**. The data field highlights and the remote automatically connects with the base station.
9. Select **Link Monitor Period** and press **Enter**. The data field highlights.
10. Type a link monitor period (1) and press **Enter**. Link Monitor starts as soon as a non-zero value is entered in the field. (A setting of 1 means that 50% of all data is test data.)
11. View the link statistics. From the Main Menu select **Link Monitor Display** and press **Enter**. The RF Link Monitor Statistics window is displayed.

```

RF Link Monitor Statistics

Link Monitor Rank                1
Base to Remote BER               0.0E+00
Remote to Base BER               0.0E+00
Missed Packet Count              0
Base to Remote Env Power         27
Base to Remote Corr Power        28
Remote to Base Env Power         29
Remote to Base Corr Power        30
    
```

12. Check for BER = 0.0E+00 and Corr Power between 15 – 50 dB. If the Corr Power is <15 dB the receive signal is probably too weak. If the power is >55 dB the receiving unit is probably saturated. See [Viewing Link Monitor Statistics](#), page 96 for more information about Link Monitor Statistics. If you have problems, ensure that the unit is configured to its basic default settings (see [Restoring Factory Configurations](#), page 94) and reconfigure the unit or contact Wi-LAN customer support.

13. When you finish viewing link monitor statistics, disable Link Monitor to remove the test overhead data from the RF link. Select **RF Station Configuration** from the Main Menu and press **Enter**. The RF Station Configuration menu is displayed.
14. Select **Link Monitor Period** and press **Enter**. The field is highlighted.
15. Type 0 in the field and press **Enter**. The link monitor test ends.
16. Press **Esc** to exit.

Note: When testing, it is possible to run the link monitor in both directions over one link by enabling link monitor on the base and the remote at the same time. This situation should be avoided during normal operation because it causes needless overhead.

Performing Transmit and Receive Tests

When performing transmit or receive tests, one unit is set up to operate in Transmit Test mode and the other unit is set up to operate in Receive Test mode. The transmitting unit sends packets of known data to the receiving unit. The receiving unit analyzes the data and displays link statistics on the PC connected to the MANAGEMENT port.

To set up the transmit unit

1. Connect a PC to the MANAGEMENT port of the unit.
2. Log in to the unit and go to the Main Menu.
3. From the Main Menu, select **RF Station Configuration** and press **Enter**. The RF Station Configuration menu is displayed.
4. Select **Operating Mode** and press **Enter**. The field highlights.
5. Select **Transmit Test** and press **Enter**. The MODE LED on the unit is **red**, indicating that the unit is transmitting.

To set up the receive unit

1. Connect a PC to the MANAGEMENT port of the unit.
2. Log in to the unit and go to the Main Menu.
3. From the Main Menu, select **RF Station Configuration** and press **Enter**. The RF Station Configuration menu is displayed.
4. Select **Operating Mode** and press **Enter**. The field highlights.
5. Select **Receive Test** and press **Enter**. The MODE LED on the turns **green**, indicating that the unit is receiving. The link statistics are displayed on the receiving unit. Alternating lines of statistics across the screen indicate that data is incoming. See the following example.

Link Statistics Example

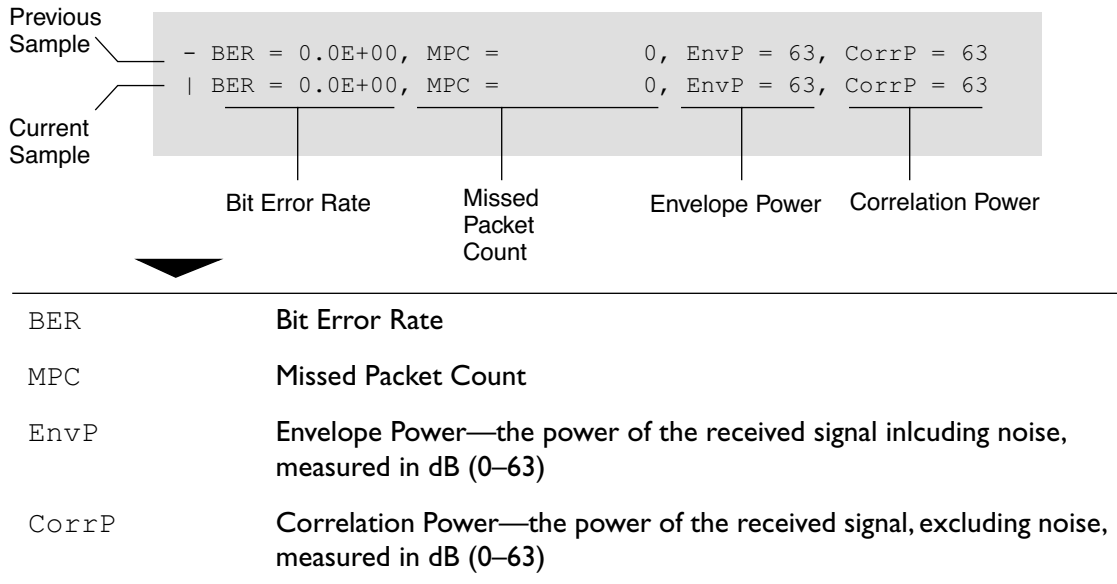

6. Check for BER = 0.0E+00 and CorrP between 15 – 50 dB. If the CorrP is <15 dB the receive signal is probably too weak. If the power is >55 dB the receiving unit is probably saturated. If you have problems ensure that the unit is configured to its basic default settings (see [Restoring Factory Configurations](#), page 94) and reconfigure the unit, or contact Wi-LAN customer support.
7. To end the test, briefly disconnect power from the unit or press and hold the MODE button to return to Normal mode.

Performing the RSSI Test

RSSI mode is used to measure the signal strength (fade margin) of a system. When running the test between two units, the transmit unit is set to Transmit Test mode (using either the RF Station Configuration menu or the MODE button). The receive unit is put into RSSI Test mode (using either the RF Station Configuration menu or the MODE button). The AIR LED on the receiving unit indicates the fade margin.



To run the RSSI test

1. Put the receiving unit into RSSI mode. See [Setting the Operating Mode](#), page 49 or [Setting Operating Mode with the MODE Button](#), page 97. The MODE LED is **orange** when the unit is in RSSI mode.
2. Put the transmitting unit into `Transmit Test` mode. The MODE LED on the unit is **red**, indicating that the unit is in transmit mode. See [Setting the Operating Mode](#), page 49 or [Setting Operating Mode with the MODE Button](#), page 97.
3. Observe the color of the AIR LED on the receiving unit. The AIR LED is **green** when the signal strength is acceptable.

AIR LED Color	Signal Strength
Green	Reliable signal—greater than 15 dB fade margin
Orange	Marginal signal—between 11 and 15 dB fade margin
Red	Poor signal—less than 10 dB fade margin
Blank	No signal at all

4. To exit from the test, briefly disconnect power from the unit or press and hold the MODE button to return to Normal mode.

Setting the RF Transmit Status

This setting can block a unit (or link) from carrying data traffic. It is used to disable units and to discontinue service to customers if necessary.

► To set RF transmit status

1. From the Main Menu, select **RF Station Configuration** and press **Enter**. The RF Station Configuration menu is displayed.

```

RF Station Configuration

Operating Mode                Normal Mode
RF Transmit Status           -> unblocked
Link Monitor Period (0=OFF, 1-10000)  0
Test Mode Timer Minutes (1-1000)    5

Base Station Only Parameters

Maximum Remote Distance       5 Km
Link Monitor Remote Station Rank  1

Remote Station Only Parameters
Throttle Enable               off
Throttle Level (1-50)        1
    
```

2. Select **RF Transmit Status** and press **Enter**. The data field highlights.
3. Select a setting.

unblocked	Unit passes data in both directions(default setting)
blocked	Will not pass data in either direction

4. Press **Enter**.
5. Press **Esc** to exit to the Main Menu.

Setting the Link Monitor Period

The Link Monitor Period determines the ratio of test data to message data that is sent when you run the link monitor test. The higher the period number, the smaller the ratio of test data to message data. The following diagram shows the ratios of test data to link data

Link Monitor Period Settings

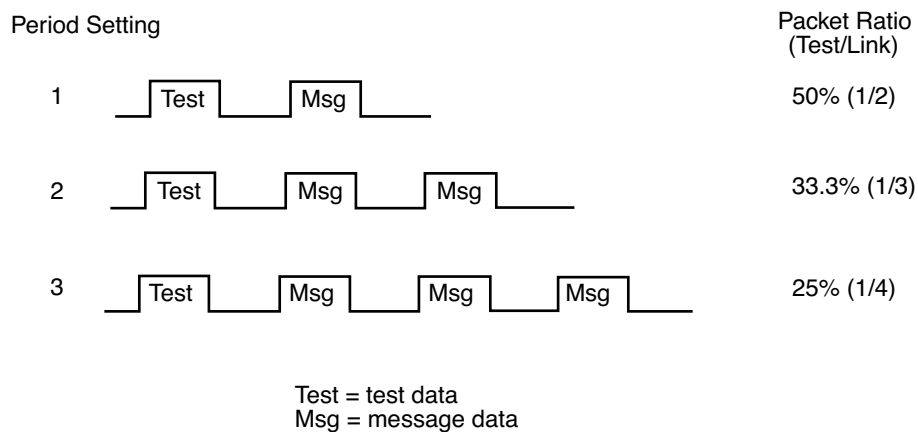

See [Performing Link Monitor Test \(Normal Mode\)](#), page 52 for information about running the Link Monitor test.

▶ To set Link Monitor Period

1. From the Main Menu, select **RF Station Configuration** and press **Enter**. The RF Station Configuration menu is displayed.

```

RF Station Configuration

Operating Mode                Normal Mode
RF Transmit Status           unblocked
Link Monitor Period (0=OFF, 1-10000) -> 1
Test Mode Timer Minutes (1-1000) 5

Base Station Only Parameters

Maximum Remote Distance       5 Km
Link Monitor Remote Station Rank 1

Remote Station Only Parameters
Throttle Enable               off
Throttle Level (1-50)         1

```

2. Select **Link Monitor Period** and press **Enter**. The data field highlights.
3. Type the period setting (0=OFF, 1-10000)
4. Press **Enter**. The test starts as soon as a non-zero value is entered.
5. Press **Esc** to exit to the Main Menu.

Setting Maximum Remote Distance (Base Station Only)

The Maximum Remote Distance setting is used to optimize dynamic polling by compensating for time delays caused by long distances between the sending unit and the receiving unit.

IMPORTANT

In the base unit, the Maximum Remote Distance should always be set to the distance between the base and the farthest remote.

▶ To set the maximum remote distance

1. From the Main Menu, select **RF Station Configuration** and press **Enter**. The RF Station Configuration menu is displayed.

```

RF Station Configuration

Operating Mode                Normal Mode
RF Transmit Status           unblocked
Link Monitor Period (0=OFF, 1-10000)  0
Test Mode Timer (1-1000)mins  5

Base Station Only Parameters

▶ Maximum Remote Distance     -> 5 Km
Link Monitor Remote Station Rank  1

Remote Station Only Parameters
Throttle Enable              off
Throttle Level (1-50)       1
    
```

2. Select **Maximum Remote Distance** and press **Enter**. The data field highlights.
3. Press the arrow keys to set the distance of the furthest remote unit (5 km increments are used).
4. Press **Enter**.
5. Press **Esc** to exit to the Main Menu.

Setting Link Monitor Remote Station Rank

When you run the Link Monitor Test from a base station, you need to specify the rank (ID number) of the remote that you want to test. When you run the link monitor test from a remote, there is only one base, so the rank number does not need to be entered.

► To set the link monitor remote station rank

1. From the Main Menu, select **RF Station Configuration** and press **Enter**. The RF Station Configuration menu is displayed.

```

RF Station Configuration

Operating Mode                Normal Mode
RF Transmit Status           unblocked
Link Monitor Period (0-OFF, 1-10000)  0
Test Mode Timer Minutes (1-1000)    5

Base Station Only Parameters

Maximum Remote Distance       5 Km
Link Monitor Remote Station Rank -> 1

Remote Station Only Parameters
Throttle Enable               off
Throttle Level (1-50)        1

```

2. Select **Link Monitor Remote Station Rank** and press **Enter**. The data field highlights.
3. Type the station rank (ID#) of the remote to test.
4. Press **Enter**.
5. Press **Esc** to exit to the Main Menu.

Adjusting Throttling (Remote Station Only)

Throttling enables you to control the rate that data passes through a remote, so data throughput can be adjusted to make the data rate compatible with the rest of the system. Throttling restricts the flow of data from air to wire or from wire to air. When throttling is enabled, the amount of data passed is equal to the throttling level times 128 kbps, to a maximum of 6.4 Mbps. Throttling applies to both down link and up link traffic, so a throttle level of 1 means the unit will pass 128 kbps in each direction. A throttle level of 50 means that 50 x 128 kbps will be passed. When throttling is disabled, the unit uses the maximum available bandwidth. The default setting is to disable throttling.

► To enable throttling

1. From the Main Menu, select **RF Station Configuration** and press **Enter**. The RF Station Configuration menu is displayed.

```

RF Station Configuration

Operating Mode                Normal Mode
RF Transmit Status           unblocked
Link Monitor Period (0=OFF, 1-10000)  0
Test Mode Timer (1-1000)mins  5

Base Station Only Parameters

Maximum Remote Distance      5 Km
Link Monitor Remote Station Rank  1

Remote Station Only Parameters
▶ Throttle Enable             -> off
Throttle Level (1-50)        1

```

2. Select **Throttle Enable** and press **Enter**. The data field highlights.
3. Scroll to select **on** or **off**, and press **Enter**.
4. Press **Esc** to exit to the Main Menu.

► To set the throttle level

1. Set Throttle Enable to on, then select **Throttle Level** from the RF Configuration menu and press **Enter**. The data field highlights.
2. Type a value from 1–50 to select the data throughput rate (where 1 = 1 x 128 kbps, 50 = 50 x 128 kbps) and press **Enter**.
3. Press **Esc** to exit to the Main Menu.

Radio Module Configuration

The Radio Module Configuration menu is used to change several key parameters, including station type, station rank and security passwords. Because these settings can affect service, they are changed in three progressive stages: new, current, and flash. (New and current are for temporary storage, while flash is for long-term storage.) The general procedure for changing settings with the Radio Module Configuration menu follows.

1. View the current Radio Module Configuration menu. See [Viewing the Radio Module Configuration](#), page 63.
2. Select **Config Test Minutes**. To begin, enter a time of 15–20 minutes. See [Setting Config Test Minutes](#), page 65.
3. Select a parameter and, if necessary, change the value in the "New" column.
4. After making changes, select **Reboot New RF Configuration** and press **Enter**. The unit reboots and the "New" settings become the "Current" settings of the unit. See [Rebooting and Saving RF Module Configurations](#), page 79.
5. If the unit operates as expected, you can save the current settings to "Flash". See [Rebooting and Saving RF Module Configurations](#), page 79.

If current settings *do not* operate as expected, do not save them to "Flash". Change the current settings or wait for the **Config Test Minutes** time period to expire. At expiry, the unit will automatically reboot and revert to the last-saved flash memory settings. See [Rebooting and Saving RF Module Configurations](#), page 79.

Viewing the Radio Module Configuration

▶ To view the current radio module configuration

1. From the Main Menu, select **Radio Module Configuration** and press **Enter**. The Radio Module Configuration menu is displayed.

Radio Module Configuration			
	New	Current	Flash
Station Type	-> Remote Unit	Remote Unit	Remote Unit
Station Rank (1-1000)	1	1	1
Center Frequency	2.4400 GHz	2.4400 GHz	2.4400 GHz
Security Password 1 (Hex)	1	1	1
Security Password 2 (Hex)	10	10	10
Security Password 3 (Hex)	100	100	100
Security Password 4 (Hex)	1000	1000	1000
Security Password 5 (Hex)	10000	10000	10000
Scrambling Code (Hex)	0	0	0
Acquisition Code (0-15)	1	1	1
Config Test Minutes (1-120)	30	30	30
Base Station Only Parameters			
Repeater Mode	off	off	off
System Symmetry Type	Asymmetric	Asymmetric	Asymmetric
Dynamic Polling Level (1-100)	1		
Remote Station Only Parameters			
Remote Unit RF Group (0-63)	0	0	0
Reboot New RF configuration	Press Enter to Execute		
Save Current Config to Flash	Press Enter to Execute		

Station Type	Defines unit as either a base station or a remote station
Station Rank	For a base station, the number of remotes that the base polls For a remote, the polling ID # of the remote.
Center Frequency	Defines the channel the unit uses to transmit and receive.
Security Password <i>n</i>	Password(s) for the unit.
Scrambling Code	Code used to scramble messages
Acquisition Code	Code used to reduce system-induced interference in a multi-sector system
Config Test Minutes	Amount of time before unit returns to its pre-configuration state
Repeater Mode	Sets up a base station to pass data to and from remotes rather than function as a control unit
System Symmetry Type	Defines the amount of priority the base unit has when polling the remotes
Dynamic Polling Level	Number of polling cycles that inactive remote units are ignored by the base station
Remote Unit RF Group	Identifies the group number of the remote unit. Remote units with same RF group number can communicate directly with each other
Reboot new RF configuration	Reboots unit to save New settings as Current settings
Save Current Config to Flash	Stores current settings in flash memory

2. Press **Esc** to exit to the Main Menu.

Setting Config Test Minutes

When changing Radio Module Configuration settings, you may enter settings that cause a unit or system to not function as expected. If this happens, you can return to the last-saved settings *if you first set the Config Test Minutes test period*. When this test period expires, the unit automatically reboots and returns to its last-saved flash memory settings. The time period can be fixed from 1 to 120 minutes.

Tip: To begin, enter a time period of 30 minutes. If the time period is too short, you will not have enough time to make configuration changes and save them to flash ROM. If the time period is long, you will have to wait a long time before the unit automatically reboots and restores the settings to the original flash ROM state.

▶ To set the config test timeout period

1. From the Main Menu, select **Radio Module Configuration** and press **Enter**. The Radio Module Configuration menu is displayed.

Radio Module Configuration			
	New	Current	Flash
Station Type	Remote Unit	Remote Unit	Remote Unit
Station Rank (1-1000)	1	1	1
Center Frequency	2.4400 GHz	2.4400 GHz	2.4400 GHz
Security Password 1 (Hex)	1	1	1
Security Password 2 (Hex)	10	10	10
Security Password 3 (Hex)	100	100	100
Security Password 4 (Hex)	1000	1000	1000
Security Password 5 (Hex)	10000	10000	10000
Scrambling Code (Hex)	0	0	0
Acquisition Code (0-15)	0	0	0
▶ Config Test Minutes (1-120)	-> 30	30	30
Base Station Only Parameters			
Repeater Mode	off	off	off
System Symmetry Type	Asymmetric	Asymmetric	Asymmetric
Dynamic Polling Level (1-100)	1		
Remote Station Only Parameters			
Remote Unit RF Group (0-63)	0	0	0
Reboot New RF configuration	Press Enter to Execute		
Save Current Config to Flash	Press Enter to Execute		

2. Select **Config Test Minutes** and press **Enter**. The data field highlights.
3. Type the number of minutes (1-120) and press **Enter**. The number of minutes is stored in the *New* state.
4. Select **Reboot New RF Configuration** and press **Enter**. The unit reboots and the Hopper Plus 120-24 Login menu is displayed. The unit will now use the current settings to operate, for the length of time specified by the *Current Test Minutes*.
5. To save the current setting(s) to flash memory, log in, go to the Main Menu, and select **Radio Module Configuration, Save Current Config to Flash**. See [Rebooting and Saving RF Module Configurations](#), page 79.
6. Press **Esc** to exit to the Main Menu.

Setting the Station Type

Each unit must be set up as either a base station or a remote station. In a given system there is only one base station, but there can be numerous remote stations. (A base station can also be set up as a repeater base.) You define the unit as a base station or remote unit by setting the Station Type.

▶ To set the station type

1. From the Main Menu, select **Radio Module Configuration** and press **Enter**. The Radio Module Configuration menu is displayed.

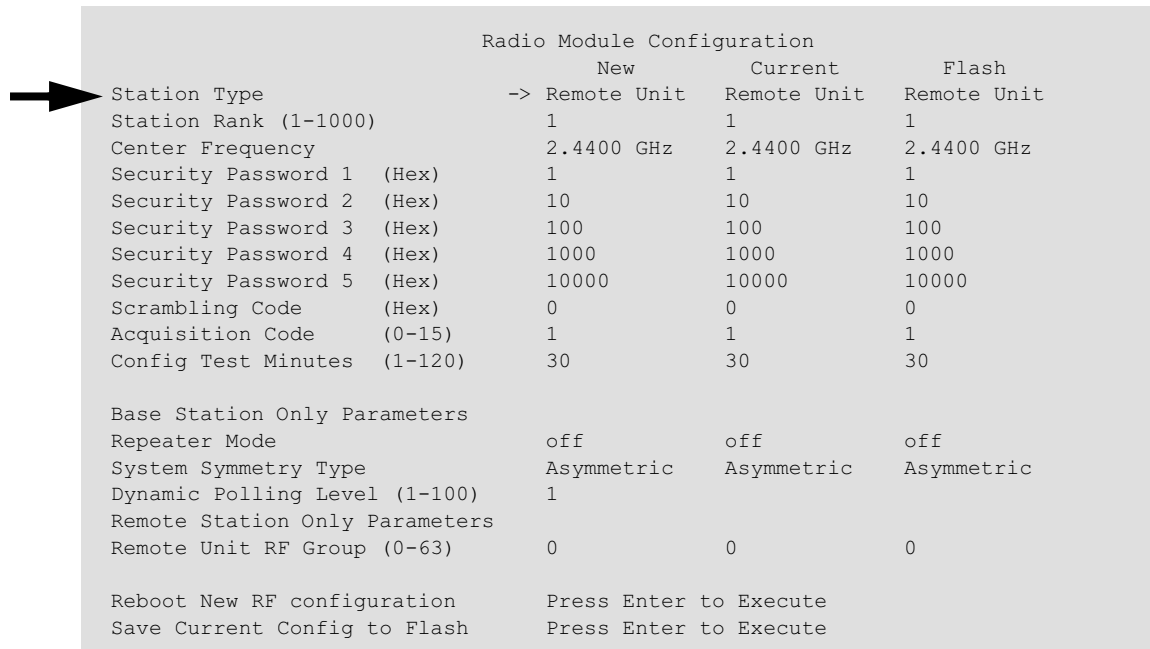

Radio Module Configuration				
	New	Current	Flash	
Station Type	-> Remote Unit	Remote Unit	Remote Unit	
Station Rank (1-1000)	1	1	1	
Center Frequency	2.4400 GHz	2.4400 GHz	2.4400 GHz	
Security Password 1 (Hex)	1	1	1	
Security Password 2 (Hex)	10	10	10	
Security Password 3 (Hex)	100	100	100	
Security Password 4 (Hex)	1000	1000	1000	
Security Password 5 (Hex)	10000	10000	10000	
Scrambling Code (Hex)	0	0	0	
Acquisition Code (0-15)	1	1	1	
Config Test Minutes (1-120)	30	30	30	
Base Station Only Parameters				
Repeater Mode	off	off	off	
System Symmetry Type	Asymmetric	Asymmetric	Asymmetric	
Dynamic Polling Level (1-100)	1			
Remote Station Only Parameters				
Remote Unit RF Group (0-63)	0	0	0	
Reboot New RF configuration	Press Enter to Execute			
Save Current Config to Flash	Press Enter to Execute			

2. Select **Station Type** and press **Enter**. The data field highlights.
3. Scroll to select the Station Type (base station or remote unit).
4. Press **Enter**. The new setting is displayed in the "New" column.
5. Select **Reboot New RF Configuration** and press **Enter**. The unit reboots and the Hopper Plus 120-24 Login menu is displayed. The unit now runs using the "Current" station type for the amount of time specified by the Current Test Minutes.
6. To save the current setting(s) to flash memory, log in, go to the Main Menu, and select **Radio Module Configuration, Save Current Config to Flash**. See [Rebooting and Saving RF Module Configurations](#), page 79.
7. Press **Esc** to exit to the Main Menu.

Setting the Station Rank

Station Rank is defined two different ways, which depend on the station type: For a base station, rank is the *total number of remotes* that a base will poll. For a remote unit, rank is a unique *polling ID number* that identifies a remote to a base station.

When it polls remotes, the base station begins polling at the remote with rank number 1, then proceeds to the remote with rank number 2, then goes to the remote with rank number 3, and so on. The base continues polling remotes until it reaches the remote with the highest rank number. The base then repeats the polling cycle.

Note: Dynamic polling gives you some control over the polling process. See [Setting Dynamic Polling Level \(Base Station Only\)](#), page 75.

▶ To set the station rank

1. From the Main Menu, select **Radio Module Configuration** and press **Enter**. The Radio Module Configuration menu is displayed.

	Radio Module Configuration		
	New	Current	Flash
Station Type			
Station Rank (1-1000)	-> 1	1	1
Center Frequency	2.4400 GHz	2.4400 GHz	2.4400 GHz
Security Password 1 (Hex)	1	1	1
Security Password 2 (Hex)	10	10	10
Security Password 3 (Hex)	100	100	100
Security Password 4 (Hex)	1000	1000	1000
Security Password 5 (Hex)	10000	10000	10000
Scrambling Code (Hex)	0	0	0
Acquisition Code (0-15)	1	1	1
Config Test Minutes (1-120)	30	30	30
Base Station Only Parameters			
Repeater Mode	off	off	off
System Symmetry Type	Asymmetric	Asymmetric	Asymmetric
Dynamic Polling Level (1-100)	1		
Remote Station Only Parameters			
Remote Unit RF Group (0-63)	0	0	0
Reboot New RF configuration	Press Enter to Execute		
Save Current Config to Flash	Press Enter to Execute		

2. Select **Station Rank (1-1000)**.
3. Type the rank (a number from 1-1000) of the station.
4. Press **Enter**. The new setting is displayed in the "New" column.
5. Select **Reboot New RF Configuration** and press **Enter**. The unit reboots and the Hopper Plus 120-24 Login menu is displayed. The unit now runs using the "Current" rank for the amount of time specified by the *Current Test Minutes*.
6. To save the current setting(s) to flash memory, log in, go to the Main Menu, and select **Radio Module Configuration, Save Current Config to Flash**. See [Rebooting and Saving RF Module Configurations](#), page 79.
7. Press **Esc** to exit to the Main Menu.

Setting the Center Frequency

The center frequency defines the channel a unit uses to transmit and receive. To ensure communication between units, all units in a system must have the same center frequency value.

▶ To set the center frequency

1. From the Main Menu, select **Radio Module Configuration** and press **Enter**. The Radio Module Configuration menu is displayed.

Radio Module Configuration			
	New	Current	Flash
Station Type	Remote Unit	Remote Unit	Remote Unit
Station Rank (1-1000)	1	1	1
Center Frequency	-> 2.4400 GHz	2.4400 GHz	2.4400 GHz
Security Password 1 (Hex)	1	1	1
Security Password 2 (Hex)	10	10	10
Security Password 3 (Hex)	100	100	100
Security Password 4 (Hex)	1000	1000	1000
Security Password 5 (Hex)	10000	10000	10000
Scrambling Code (Hex)	0	0	0
Acquisition Code (0-15)	1	1	1
Config Test Minutes (1-120)	30	30	30
Base Station Only Parameters			
Repeater Mode	off	off	off
System Symmetry Type	Asymmetric	Asymmetric	Asymmetric
Dynamic Polling Level (1-100)	1		
Remote Station Only Parameters			
Remote Unit RF Group (0-63)	0	0	0
Reboot New RF configuration	Press Enter to Execute		
Save Current Config to Flash	Press Enter to Execute		

2. Select **Center Frequency** and press **Enter**. The data field highlights.
3. Scroll to select the RF center frequency to apply to all units in the network.
4. Press **Enter**. The new setting is displayed in the "New" column.
5. Select **Reboot New RF Configuration** and press **Enter**. The unit reboots and the Hopper Plus 120-24 Login menu is displayed. The unit now runs using the "Current" center frequency for the amount of time specified by the Current Test Minutes.
6. To save the current setting(s) to flash memory, log in, go to the Main Menu, and select **Radio Module Configuration, Save Current Config to Flash**. See [Rebooting and Saving RF Module Configurations](#), page 79.
7. Press **Esc** to exit to the Main Menu.

Setting Security Passwords

Passwords are always exchanged between units when they communicate with each other. A set of five security passwords is assigned to each unit. The set of passwords must be exactly the same for all units in a system. (A convenient, but non-secure option is to set all passwords to "0".) The more password levels you use, the greater the security of your system. For example, using a set of five different passwords will result in a highly secure system. All units in the same network must use the same set of security passwords.

▶ To set security passwords

1. From the Main Menu, select **Radio Module Configuration** and press **Enter**. The Radio Module Configuration menu is displayed.

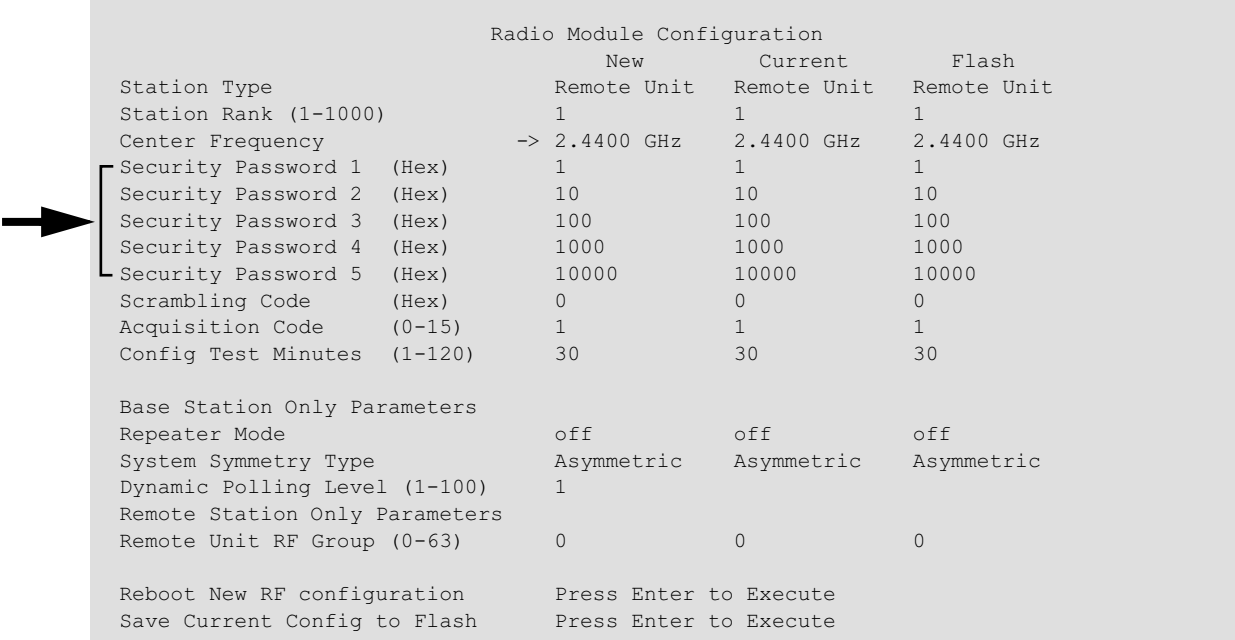

Radio Module Configuration			
	New	Current	Flash
Station Type	Remote Unit	Remote Unit	Remote Unit
Station Rank (1-1000)	1	1	1
Center Frequency	-> 2.4400 GHz	2.4400 GHz	2.4400 GHz
Security Password 1 (Hex)	1	1	1
Security Password 2 (Hex)	10	10	10
Security Password 3 (Hex)	100	100	100
Security Password 4 (Hex)	1000	1000	1000
Security Password 5 (Hex)	10000	10000	10000
Scrambling Code (Hex)	0	0	0
Acquisition Code (0-15)	1	1	1
Config Test Minutes (1-120)	30	30	30
Base Station Only Parameters			
Repeater Mode	off	off	off
System Symmetry Type	Asymmetric	Asymmetric	Asymmetric
Dynamic Polling Level (1-100)	1		
Remote Station Only Parameters			
Remote Unit RF Group (0-63)	0	0	0
Reboot New RF configuration	Press Enter to Execute		
Save Current Config to Flash	Press Enter to Execute		

2. Select **Security Password 1** and press **Enter**. The data field highlights.
3. Enter a password in Hex code and press **Enter**. The password is stored in the **New** state.
4. Select **Security Password 2** and press **Enter**. The data field highlights.
5. Enter a different password in Hex code and press **Enter**. The password is stored in the **New** state.
6. Repeat this process until you complete all five password levels.
7. Select **Reboot New RF Configuration** and press **Enter**. The unit reboots and the Hopper Plus 120-24 Login menu is displayed. The unit now runs using the "Current" set of passwords for the amount of time specified by the **Current Test Minutes**.
8. To save the current setting(s) to flash memory, log in, go to the Main Menu, and select **Radio Module Configuration, Save Current Config to Flash**. See [Rebooting and Saving RF Module Configurations](#), page 79.
9. Press **Esc** to exit to the Main Menu.

Setting the Scrambling Code

To protect the privacy of a wireless link, units can scramble messages—the message content is rearranged so that messages are difficult to read by unintended receivers. The scrambling code determines how messages are scrambled by a unit. Only units with the same scrambling code as the originating unit can de-scramble and read the message. The scrambling code can be 0-32 bits long. ^A

Setting the Acquisition Code

An acquisition code is a unique code contained within the preamble of a transmitted message. Units search the air for messages that begin with a particular acquisition code. Messages without the correct code are treated as interference and are rejected by a unit. Messages with the correct code are accepted and processed. Acquisition codes serve to isolate units from each other, especially when several units operate in close proximity or at the same frequency in a multiple-sector or multi-cell environment. All units in the same network must have the same acquisition code in order to communicate with each other.

▶ To set the acquisition code

1. From the Main Menu, select **Radio Module Configuration** and press **Enter**. The Radio Module Configuration menu is displayed.

Radio Module Configuration			
	New	Current	Flash
Station Type	Remote Unit	Remote Unit	Remote Unit
Station Rank (1-1000)	1	1	1
Center Frequency	2.4400 GHz	2.4400 GHz	2.4400 GHz
Security Password 1 (Hex)	1	1	1
Security Password 2 (Hex)	10	10	10
Security Password 3 (Hex)	100	100	100
Security Password 4 (Hex)	1000	1000	1000
Security Password 5 (Hex)	10000	10000	10000
Scrambling Code (Hex)	0	0	0
→ Acquisition Code (0-15)	-> 0	0	0
Config Test Minutes (1-120)	30	30	30
Base Station Only Parameters			
Repeater Mode	off	off	off
System Symmetry Type	Asymmetric	Asymmetric	Asymmetric
Dynamic Polling Level (1-100)	1		
Remote Station Only Parameters			
Remote Unit RF Group (0-63)	0	0	0
Reboot New RF configuration	Press Enter to Execute		
Save Current Config to Flash	Press Enter to Execute		

2. Select **Acquisition Code** and press **Enter**. The data field highlights.
3. Type the Acquisition code (0-15).
4. Press **Enter**. The new setting is displayed in the "New" column.
5. Select **Reboot New RF Configuration** and press **Enter**. The unit reboots and the Hopper Plus 120-24 Login menu is displayed. The unit now runs using the "Current" acquisition code for the amount of time specified by the Current Test Minutes.
6. To save the current setting(s) to flash memory, log in, go to the Main Menu, and select **Radio Module Configuration, Save Current Config to Flash**. See [Rebooting and Saving RF Module Configurations](#), page 79.
7. Press **Esc** to exit to the Main Menu.

Setting a Base to Repeater Mode (Base Station Only)

When repeater mode is enabled at a base station, the base acts as a repeater in addition to performing its normal base station functions. As a repeater, the base station receives incoming messages from remotes, stores them and broadcasts them to all remotes within RF range. Remotes belonging to the same RF group (with the same RF Group number) can communicate via the repeater. (See [Setting Remote Unit RF Group](#), page 76 for information about RF groups.) The following diagram explains the process.

Repeater Mode

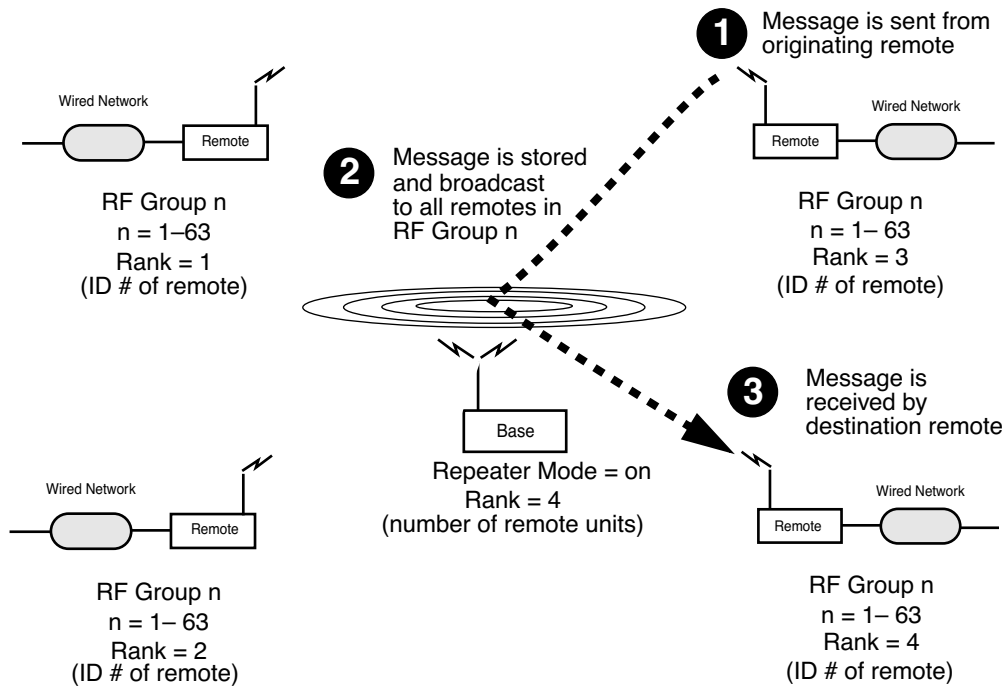

When repeater mode is disabled (Repeater Mode = off), the base station functions normally (it polls remotes and links the various segments of the network). By definition, Repeater Mode does not apply to units of RF Group = 0.

▶ To set base to repeater mode

1. From the Main Menu, select **Radio Module Configuration** and press **Enter**. The Radio Module Configuration menu is displayed.

Radio Module Configuration			
	New	Current	Flash
Station Type	Remote Unit	Remote Unit	Remote Unit
Station Rank (1-1000)	1	1	1
Center Frequency	2.4400 GHz	2.4400 GHz	2.4400 GHz
Security Password 1 (Hex)	1	1	1
Security Password 2 (Hex)	10	10	10
Security Password 3 (Hex)	100	100	100
Security Password 4 (Hex)	1000	1000	1000
Security Password 5 (Hex)	10000	10000	10000
Scrambling Code (Hex)	0	0	0
Acquisition Code (0-15)	0	0	0
Config Test Minutes (1-120)	30	30	30
Base Station Only Parameters			
▶ Repeater Mode	-> off	off	off
System Symmetry Type	Asymmetric	Asymmetric	Asymmetric
Dynamic Polling Level (1-100)	1		
Remote Station Only Parameters			
Remote Unit RF Group (0-63)	0	0	0
Reboot New RF configuration	Press Enter to Execute		
Save Current Config to Flash	Press Enter to Execute		

2. Select **Repeater Mode** and press **Enter**. The data field highlights.
3. Scroll to select the desired setting where:

off	Base unit does not re-transmit messages—default setting
on	Base unit re-transmits messages received from one remote to other remotes in same RF group

4. Press **Enter**. The new setting is displayed in the "New" column.
5. Select **Reboot New RF Configuration** and press **Enter**. The unit reboots and the Hopper Plus 120-24 Login menu is displayed. The unit now runs using the "Current" repeater mode for the amount of time specified by the `Current Test Minutes`.
6. To save the current setting(s) to flash memory, log in, go to the Main Menu, and select **Radio Module Configuration, Save Current Config to Flash**. See [Rebooting and Saving RF Module Configurations](#), page 79.
7. Press **Esc** to exit to the Main Menu.

Setting System Symmetry Type (Base Station Only)

System symmetry type fixes the priority of the base unit when it polls remotes. The default "asymmetric" setting alots the base one time slot for each time a remote is polled—this setting is useful when the base is the access point to a large network. The "symmetric" setting alots the base one time slot per *polling cycle*. A symmetric system gives the base station the same polling priority as a remote unit.

▶ To set system symmetry type

1. From the Main Menu, select **Radio Module Configuration** and press **Enter**. The Radio Module Configuration menu is displayed.

Radio Module Configuration			
	New	Current	Flash
Station Type	Remote Unit	Remote Unit	Remote Unit
Station Rank (1-1000)	1	1	1
Center Frequency	2.4400 GHz	2.4400 GHz	2.4400 GHz
Security Password 1 (Hex)	1	1	1
Security Password 2 (Hex)	10	10	10
Security Password 3 (Hex)	100	100	100
Security Password 4 (Hex)	1000	1000	1000
Security Password 5 (Hex)	10000	10000	10000
Scrambling Code (Hex)	0	0	0
Acquisition Code (0-15)	0	0	0
Config Test Minutes (1-120)	30	30	30
Base Station Only Parameters			
Repeater Mode	off	off	off
System Symmetry Type	-> Asymmetric	Asymmetric	Asymmetric
Dynamic Polling Level (1-100)	1		
Remote Station Only Parameters			
Remote Unit RF Group (0-63)	0	0	0
Reboot New RF configuration	Press Enter to Execute		
Save Current Config to Flash	Press Enter to Execute		

2. Select **System Symmetry Type** and press **Enter**. The data field highlights.
3. Scroll to the desired setting where:

asymmetric	Base unit has higher priority than remotes: the base unit has one time slot after every remote time slot. Default setting
symmetric	Base unit has the same priority as all remotes: the base unit has one time slot for every polling cycle

4. Press **Enter**. The new setting is displayed in the "New" column.
5. Select **Reboot New RF Configuration** and press **Enter**. The unit reboots and the Hopper Plus 120-24 Login menu is displayed. The unit now runs using the "Current" symmetry type for the amount of time specified by the Current Test Minutes.
6. To save the current setting(s) to flash memory, log in, go to the Main Menu, and select **Radio Module Configuration, Save Current Config to Flash**. See [Rebooting and Saving RF Module Configurations](#), page 79.
7. Press **Esc** to exit to the Main Menu.

Setting Dynamic Polling Level (Base Station Only)

Dynamic polling improves system performance by reducing overhead due to idle remote units. A base station automatically learns which remote stations are active and which are idle. The base station waits a brief time period for a remote to respond to a poll. If the remote doesn't respond within the time period, the base considers the remote to be idle. (This process is called dynamic time allocation or DTA.) Idle remote units are ignored by the base station for the number of polling rounds entered in the Dynamic Polling Level field. The higher the dynamic polling level, the more efficient the throughput and the longer it takes to move a subscriber from an inactive state to an active state. Dynamic Polling improves system performance whenever there is more than one remote. When there are a large number of remotes system performance improves significantly.

Note: Polling level is set only at the base station.

▶ To set the dynamic polling level

1. From the Main Menu, select **RF Station Configuration** and press **Enter**. The RF Station Configuration menu is displayed.

Radio Module Configuration			
	New	Current	Flash
Station Type	Remote Unit	Remote Unit	Remote Unit
Station Rank (1-1000)	1	1	1
Center Frequency	2.4400 GHz	2.4400 GHz	2.4400 GHz
Security Password 1 (Hex)	1	1	1
Security Password 2 (Hex)	10	10	10
Security Password 3 (Hex)	100	100	100
Security Password 4 (Hex)	1000	1000	1000
Security Password 5 (Hex)	10000	10000	10000
Scrambling Code (Hex)	0	0	0
Acquisition Code (0-15)	0	0	0
Config Test Minutes (1-120)	30	30	30
Base Station Only Parameters			
Repeater Mode	off	off	off
System Symmetry Type	-> Asymmetric	Asymmetric	Asymmetric
Dynamic Polling Level (1-100)	1		
Remote Station Only Parameters			
Remote Unit RF Group (0-63)	0	0	0
Reboot New RF configuration	Press Enter to Execute		
Save Current Config to Flash	Press Enter to Execute		

1. Select **Dynamic Polling Level** and press **Enter**. The data field highlights.
2. Type the desired polling level (1-60).
3. Press **Enter**. The new setting is displayed in the "New" column.
4. Select **Reboot New RF Configuration** and press **Enter**. The unit reboots and the Hopper Plus 120-24 Login menu is displayed. The unit now runs using the "Current" dynamic polling level for the amount of time specified by the Current Test Minutes.
5. To save the current setting(s) to flash memory, log in, go to the Main Menu, and select **Radio Module Configuration, Save Current Config to Flash**. See [Rebooting and Saving RF Module Configurations](#), page 79.
6. Press **Esc** to exit to the Main Menu.

Setting Remote Unit RF Group

The RF Group setting enables you to determine which units in a system can communicate with each other. For example, in a system consisting of a base station and associated remotes, you can: 1) assign units to different groups so that only members of the same group can communicate with each other and the base (an open system); 2) isolate remotes so they cannot talk to other remotes, but can talk only to the base (a closed system); and 3) assign remote units to groups and configure the base station as a repeater (a closed system). These configurations are explained below.

Remote units with the same RF group number (RF Group = 1– 63) can communicate directly with each other and with the base station (if there is a line-of-sight RF path between units and base station Repeater Mode = off.) An example is a company where the Human Resources department needs direct access to the Payroll department, but the two departments must be isolated from other departments. Since HR and Payroll are in the same RF group 14, they can talk directly to each other, but they cannot talk directly to other groups such as R&D, which belongs to RF Group 20.

Example 1: Open System

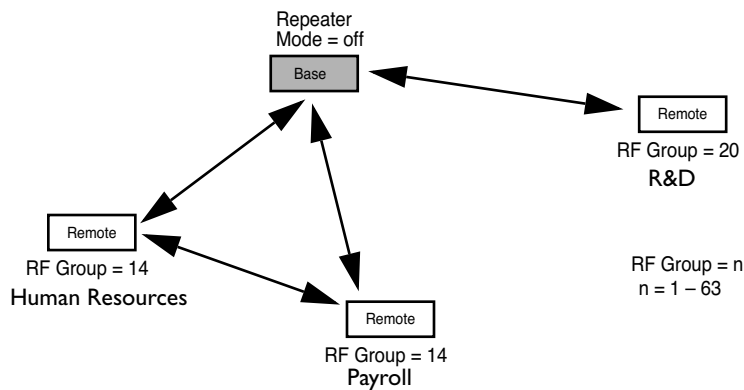

Remote units configured as RF Group = 0 are independent, closed units. Closed units cannot talk directly to each other; they can only talk directly to the base station. This setup acts to isolate remote units and the associated LANs from each other. Example 2 shows a situation where independent companies are connected wirelessly to a single base station and communication between the companies is prevented.

Example 2: Closed System

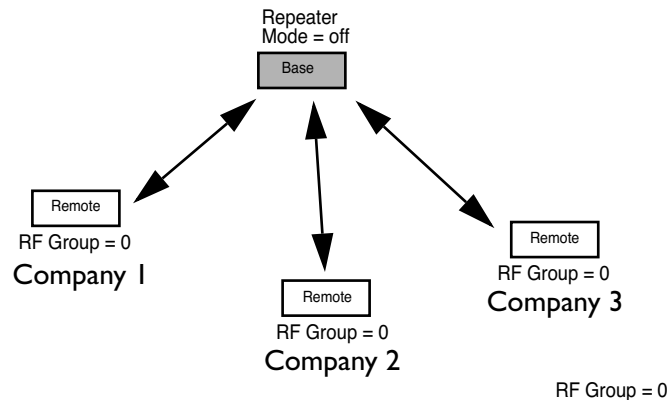

A repeater is used to bypass obstacles that block the RF path (for example, a mountain). When a base station is set to repeater mode (Repeater Mode = on), it can pass data from remotes in an RF group to other remotes in the same group. A system with a repeater is a closed system. Example 3 shows a repeater with four remotes. All the remotes are in the same RF Group 4, so they can talk to each other via the repeater base.

Example 3: Repeater Configuration (Closed System)

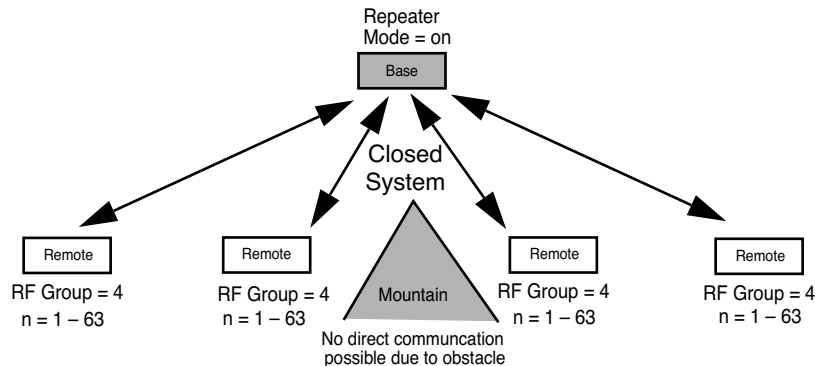

The following table summarizes the three situations.

Repeater Mode (Base only)	RF Group (Remote only)	System Type	System Characteristics
Repeater Mode = off	1-63	Open	Remotes can communicate directly with the base and each other if remotes that have the same non-zero RF group number (if a LOS RF path can be established)
Repeater Mode = off	0	Closed	Remotes can communicate only with the base station—they cannot talk to each other
Repeater Mode = on	1-63	Closed	Remotes cannot communicate directly with each other; they can only communicate via the repeater base with other remotes that have the same RF group number

▶ **To set remote unit RF group**

1. From the Main Menu, select **RF Module Configuration** and press **Enter**. The Radio Module Configuration menu is displayed.

Radio Module Configuration			
	New	Current	Flash
Station Type	Remote Unit	Remote Unit	Remote Unit
Station Rank (1-1000)	1	1	1
Center Frequency	2.4400 GHz	2.4400 GHz	2.4400 GHz
Security Password 1 (Hex)	1	1	1
Security Password 2 (Hex)	10	10	10
Security Password 3 (Hex)	100	100	100
Security Password 4 (Hex)	1000	1000	1000
Security Password 5 (Hex)	10000	10000	10000
Scrambling Code (Hex)	0	0	0
Acquisition Code (0-15)	1	1	1
Config Test Minutes (1-120)	30	30	30
Base Station Only Parameters			
Repeater Mode	off	off	off
System Symmetry Type	Asymmetric	Asymmetric	Asymmetric
Dynamic Polling Level (1-100)	1		
Remote Station Only Parameters			
Remote Unit RF Group (0-63)	-> 0	0	0
Reboot New RF configuration	Press Enter to Execute		
Save Current Config to Flash	Press Enter to Execute		

2. Select **Remote Unit RF Group** and press **Enter**. The data field highlights.
3. In the Remote Unit RF Group entry field, type the RF group number, using the following table as a guide.
4. Press **Enter**. The new setting is displayed in the "New" column.
5. Select **Reboot New RF Configuration** and press **Enter**. The unit reboots and the Hopper Plus 120-24 Login menu is displayed. The unit now runs using the "Current" remote unit RF group for the amount of time specified by the Current Test Minutes.
6. To save the current setting(s) to FLASH, log in, go to the Main Menu, and select **Radio Module Configuration, Save Current Config to Flash**. See [Rebooting and Saving RF Module Configurations](#), page 79.
7. Press **Esc** to exit to the Main Menu.

Rebooting and Saving RF Module Configurations

Because changes to Radio Module Configuration settings can affect service in a wireless system, changes are made in three progressive stages: new, current, and flash.

New	Intended configuration changes. Temporary memory storage.
Current	Configuration actually running on the unit. Temporary memory storage.
Flash	Configuration stored in FLASH memory. Long-term memory storage.

A reboot of a unit is required to save **New** settings as **Current** settings. If **Current** settings are valid (and do not disrupt the system), they can be saved to **Flash** memory. If the changes disrupt the system, the original configuration will be restored automatically when the **Config Test Minutes** period expires.

▶ To reboot a unit

1. From the Main Menu, select **Radio Module Configuration** and press **Enter**. The Radio Module Configuration menu is displayed.

Radio Module Configuration			
	New	Current	Flash
Station Type	Remote Unit	Remote Unit	Remote Unit
Station Rank (1-1000)	1	1	1
Cg Frequency	2.4400 GHz	2.4400 GHz	2.4400 GHz
Security Password 1 (Hex)	1	1	1
Security Password 2 (Hex)	10	10	10
Security Password 3 (Hex)	100	100	100
Security Password 4 (Hex)	1000	1000	1000
Security Password 5 (Hex)	10000	10000	10000
Scrambling Code (Hex)	0	0	0
Acquisition Code (0-15)	1	1	1
Config Test Minutes (1-120)	30	30	30
Base Station Only Parameters			
Repeater Mode	off	off	off
System Symmetry Type	Asymmetric	Asymmetric	Asymmetric
Dynamic Polling Level (1-100)	1		
Remote Station Only Parameters			
Remote Unit RF Group (0-63)	0	0	0
Reboot New RF configuration	-> Press Enter to Execute		
Save Current Config to Flash	Press Enter to Execute		

2. Select **Reboot New RF configuration** and press **Enter**. The unit reboots with the with new settings and with the **Config Test Minutes** timeout period in effect. The new settings can be viewed in the "Current" column of the Radio Module Configuration menu. The old, last-saved configuration remains in Flash memory.

If the configuration is the one you want and the unit operates as intended, you can save the current changes to "permanent" flash memory by selecting **Save Current Config to Flash** from the Radio Module Configuration menu. When you save the current settings to "Flash" the new settings overwrite the old flash memory settings.

▶ To save current configuration to FLASH

1. From the Main Menu, select **Radio Module Configuration** and press **Enter**. The Radio Module Configuration menu is displayed.

Radio Module Configuration			
	New	Current	Flash
	Remote Unit	Remote Unit	Remote Unit
Station Type			
Station Rank (1-1000)	1	1	1
Center Frequency	2.4400 GHz	2.4400 GHz	2.4400 GHz
Security Password 1 (Hex)	1	1	1
Security Password 2 (Hex)	10	10	10
Security Password 3 (Hex)	100	100	100
Security Password 4 (Hex)	1000	1000	1000
Security Password 5 (Hex)	10000	10000	10000
Scrambling Code (Hex)	0	0	0
Acquisition Code (0-15)	1	1	1
Config Test Minutes (1-120)	30	30	30
Base Station Only Parameters			
Repeater Mode	off	off	off
System Symmetry Type	Asymmetric	Asymmetric	Asymmetric
Dynamic Polling Level (1-100)	1		
Remote Station Only Parameters			
Remote Unit RF Group (0-63)	0	0	0
Reboot New RF configuration	Press Enter to Execute		
Save Current Config to Flash	-> Press Enter to Execute		

2. Select **Save Current Config to Flash**.
3. Press **Enter**. The current configuration is saved to flash memory. A reboot is not required. The new flash memory values are displayed in the "Flash" column of the Radio Module Configuration menu.

RF/Ethernet Statistics

Ethernet and RF statistics are useful for troubleshooting, monitoring link performance, and measuring throughput. Ethernet and RF statistics are cumulative and increment until reset. The window is view only. See [Resetting Radio and Ethernet Statistics](#), page 95 for information about resetting RF/Ethernet statistics.

Viewing RF/Ethernet Statistics

► To view RF and Ethernet statistics

- I. From the Main Menu, select **RF/Ethernet Statistics** and press **Enter**. The RF/Ethernet Statistics window is displayed. The window is view only.

```

RF/Ethernet Statistics

Ethernet Receive Statistics          Ethernet Transmit Statistics
Total Packets Received             0          Total Packets Transmitted      0
Packets For Local Host             0          Packets From Local Host       0
Receive Errors                     0          Packets Dropped                0
Packets Dropped                    0          Total KBytes Transmitted      0
Packets Discarded                  0          Broadcast KBytes Transmitted  0
Total KBytes Received              0
Broadcast KBytes Received          0

RF Receive Statistics              RF Transmit Statistics
Total Packets Received             0          Total Packets Transmitted      0
Packets For Local Host             0          Frames From Local Host        0
Packets Dropped                    0          Packets Dropped                0
Packets Discarded                  0

RF Super Frame Rx Statistics       RF Super Frame Tx Statistics
Super Frames Received              0          Super Frames Transmitted      0
Receive Overrun Errors             0
Frame Control Word Errors          0
Header Checksum Errors             0          Throughput Statistics
Packet Control Word Errors         0          Ethernet-to-RF Throughput     0
Super Frame Length Errors          0          RF-to-Ethernet Throughput     0

```

Ethernet Receive	Total Packets Received	Number of Ethernet packets from 10/100BaseT connection
	Packets For Local Host	Number of Ethernet packets received from the 10/100BaseT connection which were destined for the Hopper Plus 120-24 unit's TCP/IP stack
	Receive Errors	Number of Ethernet packets received with errors, for example, runt (smaller than 64 bytes), jabber (larger than 1518 bytes) or overflow error
	Packets Dropped	Number of Ethernet packets dropped because the wireless link is at capacity
	Packets Discarded	Number of Ethernet packets discarded as the result of filtering
	Total KBytes Received	Total number of kbytes received from the Ethernet port (broadcast and non-broadcast packets)
Broadcast KBytes Received	Number of kbytes received from the Ethernet port (broadcast packets only)	
RF Receive	Total Packets Received	Number of Ethernet packets received over RF
	Packets For Local Host	Number of Ethernet packets received over RF and destined for the local host
	Packets Dropped	Number of Ethernet packets dropped because the wireless link is at capacity
	Packets Discarded	Number of Ethernet packets discarded as the result of filtering
RF Super Frame Rx	Super Frames Received	Number of super frames received
	Receive Overrun Errors	Number of errors caused by receive buffer overrun
	Frame Control Word Errors	Number of errors caused by frame control word problems
	Header Checksum Word Errors	Number of errors caused by receiving an invalid header checksum
	Packet Control Word Errors	Number of errors caused by packet control word problems
	Super Frame Length Errors	Number of errors caused by receiving an invalid super frame length

Ethernet Transmit	Total Packets Transmitted	Number of Ethernet packets transmitted onto the 10/100BaseT connection
	Packets From Local Host	Number of Ethernet packets transmitted onto the 10/100BaseT connection which originated from the Hopper Plus 120-24 unit's TCP/IP stack
	Packets Dropped	Number of Ethernet packets not transmitted due to some error, for example, unable to transmit within 15 retries or underflow error
	Total KBytes Transmitted	Total number of kbytes transmitted from the Ethernet port (broadcast and non-broadcast packets)
	Broadcast KBytes Transmitted	Number of kbytes transmitted from the Ethernet port (broadcast packets only)
RF Transmit	Total Packets Transmitted	Number of Ethernet packets transmitted over RF
	Frames From Local Host	Number of Ethernet packets transmitted to RF from the local host
	Packets Dropped	Number of packets dropped because of RF problems
RF S. F. Tx	Super Frames Transmitted	Number of super frames transmitted
Throughput	Ethernet-to-RF Throughput	Current data rate measured from wire to air Resolution = 1 second
	RF-to-Ethernet Throughput	Current data rate measured from air to wire Resolution = 1 second

2. Press **Esc** to exit to the Main Menu.

System Security

The System Security menu is used to control access to a Hopper Plus 120-24 unit, including the following.

- Restrict access to a unit’s Main Menu with passwords
- Restrict SNMP read and write access with SNMP Community Name
- Enable or disable remote access via Ethernet
- Enable or disable remote access via a wireless link
- Determine the amount of time that a unit remains idle before it automatically logs out

Viewing System Security

 **To view system security settings**

- I. From the Main Menu, select **System Security** and press **Enter**. The System Security menu is displayed.

```

System Security

SNMP Community Name 1      -> public
SNMP Community Name 2      netman

Change User Password       Press Enter to change password
Confirm User Password      Press Enter to confirm password

Change Supervisor Password Press Enter to change password
Confirm Supervisor Password Press Enter to confirm password

Ethernet Access to Local Host on
Wireless Access to Local Host on

Auto Logout Minutes (1-120) 10
    
```

SNMP Community Name 1	Controls SNMP access to the Hopper Plus Read access only
SNMP Community Name 2	Controls SNMP access to the Hopper Plus Read and write access
Change User Password	Changes user password to enable access to main menu Read access only
Change Supervisor Password	Changes supervisor password to enable access to main menu. Read and write access
Ethernet Access to Local Host	Allows remote access to unit to change configuration settings via wire link with telnet or SNMP

Wireless Access to Local Host	Allows remote access to unit to change configuration settings via RF link with telnet or SNMP
Auto Logout Minutes	Maximum time the system can remain idle before the configuration menus close and the Login menu reappears

2. Press **Esc** to exit to the Main Menu.

Assigning Community Names

Community names can be used to control SNMP access to the Hopper Plus. Community Name 1 has read only access, and Community Name 2 has both read and write access. An SNMP manager can access and configure any Hopper Plus unit on the network as long as the unit has the correct community names and remote access is enabled (see [Allowing Remote Access and Configuration](#), page 89).

WARNING

Default community names are presented in all Installation and Configuration guides distributed by Wi-LAN. It is the responsibility of the customer to ensure that default community names are changed to unique names at installation. Record all community name changes.

Community name	Privileges	Default value
SNMP Community Name 1	Read	public
SNMP Community Name 2	Read and Write	netman

▶ To assign community names

- From the Main Menu, select **System Security** and press **Enter**. The System Security menu is displayed.

```

System Security
SNMP Community Name 1      -> public
SNMP Community Name 2      netman

Change User Password       Press Enter to change password
Confirm User Password      Press Enter to confirm password

Change Supervisor Password Press Enter to change password
Confirm Supervisor Password Press Enter to confirm password

Ethernet Access to Local Host on
Wireless Access to Local Host on

Auto Logout Minutes (1-120) 10
    
```

- Select **SNMP Community Name 1**.
- Type in name. (Valid community names are assigned using SNMP software.)
- Press **Enter**. The new name appears in the entry field.
- Select **SNMP Community Name 2**.
- Type in name. (Valid community names are assigned using SNMP software.)
- Press **Enter**. The new name appears in the entry field.
- Press **Esc** to exit to the Main Menu.

Setting Menu Passwords

You can use passwords to control access to the Main Menu. The default passwords are `user`, which allows you to read configuration settings and `supervisor`, which allows you to change configuration settings.

WARNING

The default passwords are printed in all customer documents distributed by Wi-LAN. It is the responsibility of the customer to change the default passwords to unique passwords during installation. Record all password changes. When you restore factory configurations, the login passwords revert to the defaults.

▶ To change the user password

1. From the Main Menu, select **System Security** and press **Enter**. The System Security menu is displayed.

```

                                System Security

SNMP Community Name 1           public
SNMP Community Name 2           netman

Change User Password             -> Press Enter to change password
Confirm User Password            Press Enter to confirm password

Change Supervisor Password       Press Enter to change password
Confirm Supervisor Password       Press Enter to confirm password

Ethernet Access to Local Host    on
Wireless Access to Local Host    on

Auto Logout Minutes (1-120)     10

```

2. Select **Change User Password** and press **Enter**. The data field highlights.
3. Type the new password and press **Enter**.
4. Select **Confirm User Password** and press **Enter**. The data field highlights.
5. Re-type the new password and press **Enter**. The change is saved when **Success** appears beside the confirmation field.
6. Press **Esc** to exit to the Main Menu.

► To change the supervisor password

1. From the Main Menu, select **System Security** and press **Enter**. The System Security menu is displayed.

```
System Security

SNMP Community Name 1      public
SNMP Community Name 2      netman

Change User Password      -> Press Enter to change password
Confirm User Password      Press Enter to confirm password

Change Supervisor Password  Press Enter to change password
Confirm Supervisor Password  Press Enter to confirm password

Ethernet Access to Local Host  on
Wireless Access to Local Host  on

Auto Logout Minutes (1-120)  10
```

2. Select **Change Supervisor Password** and press **Enter**. The data field highlights.
3. Type the new password and press **Enter**.
4. Select **Confirm Supervisor Password** entry field and press **Enter**.
5. Re-type the new password and press **Enter**. The change is saved when **Success** appears beside the confirmation field.
6. Press **Esc** to exit to the Main Menu.

Allowing Remote Access and Configuration

One way to control remote access to a unit's configuration menu is by restricting the *type of link* that can be used to make remote configuration changes. The default setting is to allow remote configuration changes with both wired and wireless links using telnet or SNMP. However, you can enable or disable the type of link independently with two settings: Ethernet Access to Local Host and Wireless Access to Local Host.

Note: Data will pass as usual between both units. These two settings restrict remote access to the unit's depending on the type of link that exists between the remote terminal and the unit—wired or wireless. Also, you cannot "ping" a unit if the link is disabled.

▶ To enable Ethernet and wireless access

1. From the Main Menu, select **System Security** and press **Enter**. The System Security menu is displayed.

```

                                System Security

SNMP Community Name 1          public
SNMP Community Name 2          netman

Change User Password           Press Enter to change password
Confirm User Password          Press Enter to confirm password

Change Supervisor Password     Press Enter to change password
Confirm Supervisor Password     Press Enter to confirm password

[ Ethernet Access to Local Host -> on
[ Wireless Access to Local Host  on

Auto Logout Minutes (1-120)    10

```

2. Select **Ethernet Access to Local Host** and press **Enter**. The data field highlights.
3. Select the desired setting, where:

on	Enable configuration changes to the unit via the Ethernet
off	Disable configuration changes to the unit via the Ethernet

4. Press **Enter**. The new value appears in the field.
5. Select **Wireless Access to Local Host** and press **Enter**. The data field highlights.
6. Select the desired setting where:

on	Enable configuration changes to the unit via the air
off	Disable configuration changes to the unit via the air

7. Press **Enter**. The new value appears in the field.
8. Press **Esc** to exit to the Main Menu.

Setting the Auto Logout Minutes

You can specify the maximum time the system can remain idle before the configuration menus close and the Login menu reappears. This feature ensures that the configuration menus close if a user forgets to exit.

Note: When the menus automatically timeout, the system may appear to be frozen. Press **Enter** to view the Login menu, where you can login to the Main Menu.

▶ To set the automatic logout timeout period

1. From the Main Menu, select **System Security** and press **Enter**. The System Security menu is displayed.

```
System Security

SNMP Community Name 1      public
SNMP Community Name 2      netman

Change User Password       Press Enter to change password
Confirm User Password      Press Enter to confirm password

Change Supervisor Password Press Enter to change password
Confirm Supervisor Password Press Enter to confirm password

Ethernet Access to Local Host on
Wireless Access to Local Host on

Auto Logout Minutes (1-120) -> 10
```

2. Select **Auto Logout Minutes** and press **Enter**. The data field highlights.
3. Type the maximum idle time period in minutes that can pass before the configuration menus close.
4. Press **Enter**. The new value appears in the field.
5. Press **Esc** to exit to the Main Menu.

System Commands

System image files contain the software that runs the unit. When you first power up the Hopper Plus unit, it runs from the factory-image. With the System Commands menu you can choose the image file that a unit uses to power up and the image file that a unit uses when rebooted.

Viewing System Command Menu



To view system security settings

1. From the Main Menu, select **System Commands** and press **Enter**. The System Commands menu is displayed.

```

                                System Commands

Default System Image             -> FACTORY-IMAGE
Reboot a System Image           FACTORY-IMAGE

Reboot Current Image             Press Enter to Execute
Restore Factory Config and Reboot Press Enter to Execute
Reset Radio Statistics           Press Enter to Execute
Reset Ethernet Statistics        Press Enter to Execute

```

Default System Image	Default image file used at power up
Reboot a System Image	Choose the image from which to reboot
Reboot Current Image	Reboot unit from the current image
Restore Factory Config and Reboot	Restore unit to default factory configuration and reboots unit
Reset Radio Statistics	Reset RF statistics
Reset Ethernet Statistics	Reset Ethernet statistics

2. Press **Esc** to exit to the Main Menu.

Setting Default System Image

The default image is the image file that a unit uses when it powers up. If you have more than one image saved on a unit, you can choose the default power up file.

► To set the default image

1. From the Main Menu, select **System Commands** and press **Enter**. The System Commands menu is displayed.

```

System Commands
-----
Default System Image          -> FACTORY-IMAGE
Reboot a System Image        FACTORY-IMAGE

Reboot Current Image         Press Enter to Execute
Restore Factory Config and Reboot Press Enter to Execute
Reset Radio Statistics        Press Enter to Execute
Reset Ethernet Statistics     Press Enter to Execute
    
```

2. Select **Default System Image** and press **Enter**. The data field highlights.
3. Scroll to select the image to use as the default.
4. Press **Enter**. The name of the new image file appears in the field. The image will be used the next time the Hopper Plus is powered up.
5. Press **Esc** to exit to the Main Menu.

Setting the Reboot System Image

You can choose the system image that a unit uses when it is rebooted.

► To choose the reboot image

1. From the Main Menu, select **System Commands** and press **Enter**. The System Commands menu is displayed.

```

System Commands

Default System Image           FACTORY-IMAGE
Reboot a System Image         -> FACTORY-IMAGE

Reboot Current Image          Press Enter to Execute
Restore Factory Config and Reboot Press Enter to Execute
Reset Radio Statistics         Press Enter to Execute
Reset Ethernet Statistics      Press Enter to Execute

```

2. Select **Reboot a System Image** and press **Enter**. The data field highlights.
3. Scroll to select the image to use when rebooting.
4. Press **Enter**. The name of the image file appears in the field. This image will be used the next time the Hopper Plus is rebooted.
5. Press **Esc** to exit to the Main Menu.

Rebooting the Current Image

The Reboot Current Image command can be used when the IP address is changed. See [Setting the Internet IP Address](#), page 41.

► To reboot the current image

1. From the Main Menu, select **System Commands** and press **Enter**. The System Commands menu is displayed.

```

System Commands

Default System Image           FACTORY-IMAGE
Reboot a System Image         FACTORY-IMAGE

Reboot Current Image          -> Press Enter to Execute
Restore Factory Config and Reboot Press Enter to Execute
Reset Radio Statistics         Press Enter to Execute
Reset Ethernet Statistics      Press Enter to Execute

```

2. Select **Reboot Current Image** and press **Enter**. The Hopper Plus reboots using the current image.

Restoring Factory Configurations

If necessary, you can restore the unit to its original factory configuration. This command puts the unit into a known state, which can help you when troubleshooting, and also provides an easy way to remove custom configuration settings when you deinstall a unit.

IMPORTANT

When you restore factory configurations, the login passwords reset automatically to default values (user and supervisor).

▶ To restore the factory configuration

1. From the Main Menu, select **System Commands** and press **Enter**. The System Commands menu is displayed.

```

System Commands

Default System Image           FACTORY-IMAGE
Reboot a System Image         FACTORY-IMAGE

Reboot Current Image           Press Enter to Execute
Restore Factory Config and Reboot -> Press Enter to Execute
Reset Radio Statistics         Press Enter to Execute
Reset Ethernet Statistics      Press Enter to Execute
    
```

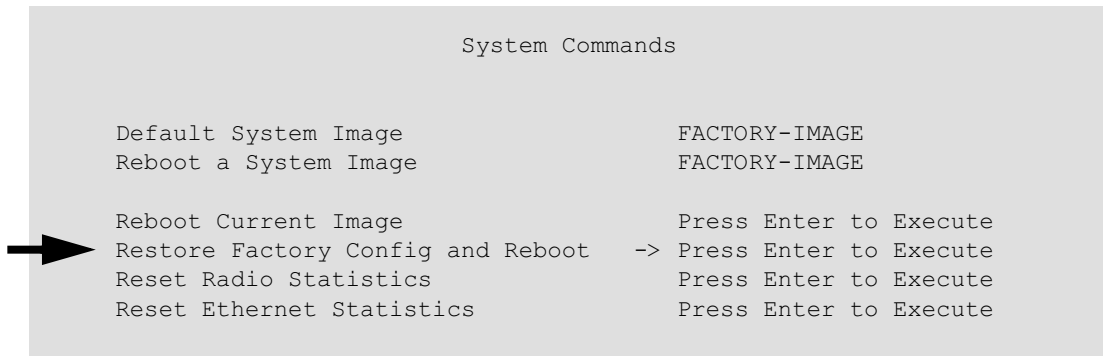

2. Select **Restore Factory Configuration and Reboot** and press **Enter**. The unit's configuration is restored to the original factory settings when the unit reboots.

Resetting Radio and Ethernet Statistics

The statistics displayed in the RF/Ethernet Statistics window are cumulative, but can be reset to track specific events and for troubleshooting. (See [Viewing RF/Ethernet Statistics](#), page 81 for information about viewing the statistics). For example, a suspected RF problem can be diagnosed by resetting the radio statistics and simulating the situation suspected of causing the problem.

▶ To reset radio statistics

1. From the Main Menu, select **System Commands**. The System Commands menu is displayed.

```

System Commands

Default System Image          FACTORY-IMAGE
Reboot a System Image        FACTORY-IMAGE

Reboot Current Image          Press Enter to Execute
Restore Factory Config and Reboot Press Enter to Execute
Reset Radio Statistics        -> Press Enter to Execute
Reset Ethernet Statistics     Press Enter to Execute
  
```

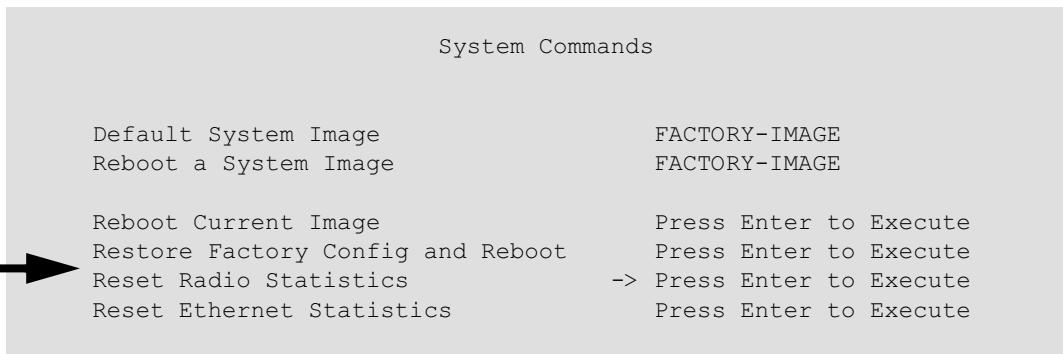

2. Select **Reset Radio Statistics** and press **Enter**. The radio statistics in the RF/Ethernet Statistics window reset to 0 when **Success** appears beside the enter field.
3. Press **Esc** to exit to the Main Menu.

▶ To reset Ethernet statistics

1. From the Main Menu, select **System Commands**. The System Commands menu is displayed.

```

System Commands

Default System Image          FACTORY-IMAGE
Reboot a System Image        FACTORY-IMAGE

Reboot Current Image          Press Enter to Execute
Restore Factory Config and Reboot Press Enter to Execute
Reset Radio Statistics        Press Enter to Execute
Reset Ethernet Statistics     -> Press Enter to Execute
  
```

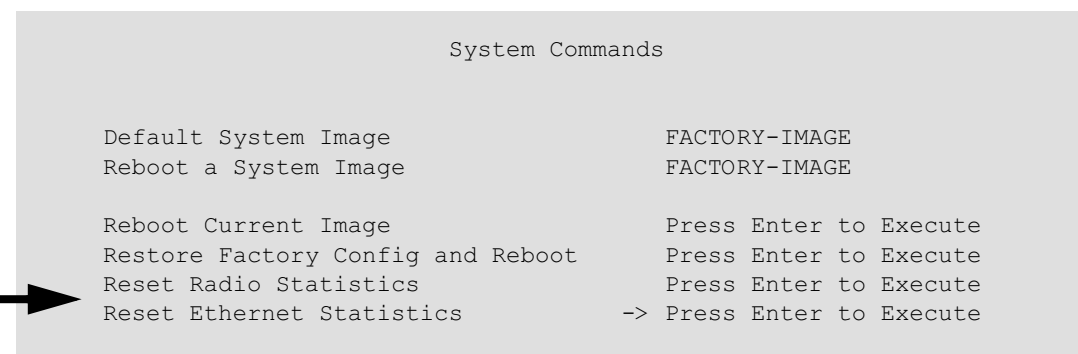

2. Select **Reset Ethernet Statistics** and press **Enter**. The Ethernet statistics in the RF/Ethernet Statistics window are reset to 0 when **Success** appears beside the enter field.
3. Press **Esc** to exit to the Main Menu.

Link Monitor Display

Viewing Link Monitor Statistics

Link performance statistics such as envelope power, correlation power and bit error rate can be viewed while the link monitor is running. Statistics are only available on the unit running the link monitor test. The window is view only.

▶ To view link monitor statistics

1. From the Main Menu, select **Link Monitor Display**. The RF Link Monitor Statistics window is displayed. The window is view only.

```

RF Link Monitor Statistics

Link Monitor Rank           0
Base to Remote BER         N/A
Remote to Base BER         N/A
Missed Packet Count        0
Base to Remote Env Power   0
Base to Remote Corr Power  0
Remote to Base Env Power   0
Remote to Base Corr Power  0
    
```

Link Monitor Rank	When run from on the base unit, it is the rank number of the remote unit whose link is being tested. When run from the remote unit, this field is zero, the rank number of the base
Base to Remote BER	Bit error rate from the base to the remote Displays "N/A" when the link monitor is not running
Remote to Base BER	Bit error rate from the remote to the base Displays "N/A" when the link monitor is not running
Missed Packet Count	Number of missed packets
Base to Remote Env Power	Envelope power received at the remote (including noise, measured in dB)
Base to Remote Corr Power	Correlation power received at the remote (excluding noise, measured in dB)
Remote to Base Env Power	Envelope power received at the base (including noise, measured in dB)
Remote to Base Corr Power	Correlation power received at the base (excluding noise, measured in dB)

Logout

Logging Out

There are two ways to log out of the main menu.

To log out of the Main Menu

From the Main Menu, select **Logout** and press **Enter**.

or

1. Press the **Esc** key on the keyboard until you reach the `wilan` command line.

```

Enter ESC to return to Main Menu
wilan> logout

```

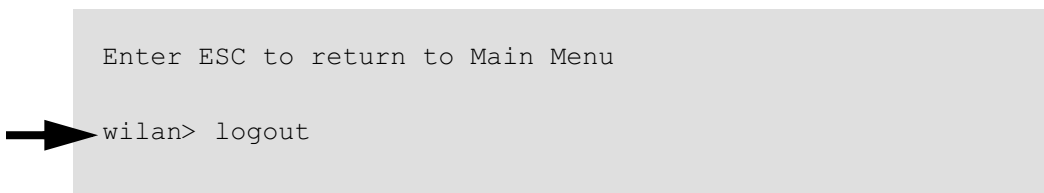

2. Type **logout** at the `wilan>` prompt.
3. Press **Enter** to log out.

Setting Operating Mode with the MODE Button

The operating mode of a unit is usually selected from the RF Station Configuration menu (see [Setting the Operating Mode](#), page 49). However, operating mode can also be set using the MODE button located on the back panel of the Hopper Plus 120-24. When you select an operating mode, the color of the MODE LED indicates the operating mode and the color of the AIR LED indicates whether a unit is transmitting, receiving, or listening.

The Hopper Plus starts up in Normal operating mode and the MODE LED is OFF. The following modes are available.

Mode	Function	Mode LED
Normal Mode	Transmit and receive in both directions—normal operating mode See Performing Link Monitor Test (Normal Mode) , page 52	OFF
Transmit Test	Transmit only See Performing Transmit and Receive Tests , page 55	Red
Receive Test	Receive only See Performing Transmit and Receive Tests , page 55	Green
RSSI Test	Received Signal Strength Indicator. Indicates fade margin data on the AIR LED See Performing the RSSI Test , page 57	Orange

Selecting RF Tests with the MODE Button

You can use the MODE button at the back of the unit to select and run RF tests. (The other method of running RF tests is with the RF Station Configuration menu. See [Setting the Operating Mode](#), page 49 for more information about running tests from a menu.)

► To select the operating mode with the mode button

1. Press the MODE button once and release it quickly. The unit goes to Transmit Test mode. MODE LED = Red.
2. Press the MODE button once and the unit goes to Receive Test mode. MODE LED = Green.
3. Press the MODE button once and the unit goes to RSSI Test mode. MODE LED = Orange.
4. Press the MODE button once and the unit returns to Transmit Test mode. MODE LED = Red.
5. To return to Normal Mode, press the MODE button and release it after at least two seconds. The AIR LED and MODE LED both turn orange when the button has been held long enough, and the MODE LED turns OFF.

MODE Button Operation

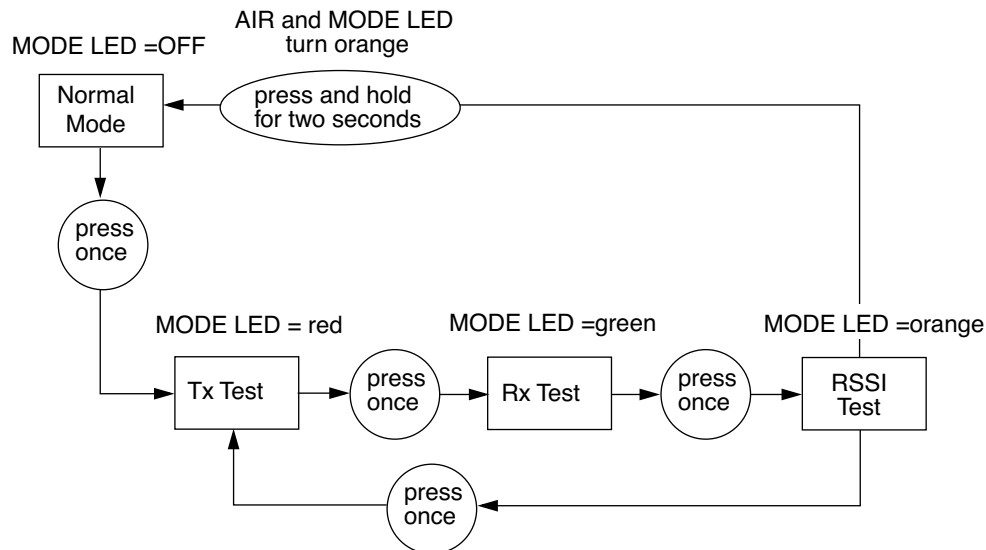

Note: If you do not manually return the unit to Normal Mode, the unit will automatically reboot and return to Normal Mode when the end of the test time period time is reached. The test time period cannot be set with the MODE button—you must use the RF Station Configuration menu to set the test mode timer minutes (see [Setting Config Test Minutes](#), page 65).

Command Line Interface

You can perform some basic commands with the command line interface. Type the commands from the prompt.

To use the command line interface

1. Log in to the Hopper unit. The Main Menu is displayed.
2. Press **Esc**. The `wilan>` prompt appears.

 `wilan>`

3. Type a command after the prompt and press **Enter**.

The following are some commands you can run with the command line interface.

Command	Action	Example
help	show the following command summary list: menu cls dir del ping logout exit quit	wilan>help menu
menu	return to the configuration menus	wilan>menu
cls	clear the terminal screen	wilan>cls
dir	show a file directory	wilan>dir
del	delete a file	wilan>del sample.txt
ping	ping a remote IP address	wilan>ping 198.168.200.5
logout	log out of the command line interface or terminate a remote telnet session	wilan>logout
exit	log out of the command line interface or terminate a remote telnet session	wilan>exit
quit	log out of the command line interface or terminate a remote telnet session	wilan>quit

Troubleshooting

Administrative Best Practices

By performing some administrative best practices and preventative maintenance, you can prevent many problems with your system, or become aware of minor problems before they become serious ones.

Wi-LAN recommends the following practices.

- Maintain the integrity of the system design when adding or changing a system. The introduction of new elements to a system can cause problems unless the network plan is revised to take into account the changes. For example, improper installation of a co-located antenna can add unwanted system interference.
- Measure and document system performance at the time of the original installation.
- Monitor system performance regularly. Environmental change as well as normal wear and tear on components can affect system performance.
- Perform preventative maintenance every 6 months. See [Preventative Maintenance and Monitoring](#), page 29 for information.
- After periods of extreme weather, perform link monitor tests to verify the system; inspect towers, antennas, cables and connectors for damage.
- Change menu passwords so that only key personnel can reconfigure the system. See [Setting Menu Passwords](#), page 87.
- Keep records of recent changes. Especially document the addition of units, hardware and software changes and changes to configuration settings. Configuration errors often cause other problems. Current records can be compared with original installation records and function as a benchmark to help you troubleshoot.
- Keep a log of past and present problems and solutions. Store the log on-site, if possible. The log identifies common failure points and fixes.
- Before contacting Wi-LAN for customer support, document the symptoms of the problem and the steps taken to diagnose and fix the problem. Record the current configuration of the system.

Troubleshooting Areas

There are five key areas to be aware of when troubleshooting.

Network Integrity: Continued performance and reliability of a network depends upon maintaining the integrity of the network. If you change a network's design, you will affect its operation. Be aware of recent changes to your network.

Quality of RF link: Data communication depends first on the quality of the RF link. If you can establish and maintain a high-quality RF link, then you can be sure the link will carry high-speed data. If the quality of the RF link is degraded for some reason, the quality of the transmitted data will also degrade.

Radio Hardware: There are three basic parts to a Hopper Plus: radio unit, antenna feed (cable, connectors, surge suppressors, patch cables etc.) and antenna. You can isolate faulty hardware using measurement and/or replacement methods.

- Verify the radio unit with diagnostic tests (such as RSSI and link monitor tests), bench test a unit, or replace a unit.
- Verify the antenna feed with a Site Master test set. Sweep cables, connectors and lightning suppressors, or exchange these parts for known good parts.
- To verify the antenna you can sweep the antenna with the Site Master test set or exchange the antenna.

Correct Unit Configuration: Units must be configured correctly, according to the network plan. Configuration errors can cause an inability to communicate or poor performance. The addition of units or changes to your system may require you to change configuration settings.

Embedded Software: Operate with a proven software image. Download new software if you suspect that a unit's software is corrupted.

The following chart provides answers to some of the more common problems that can occur when installing and using a Hopper Plus wireless ethernet bridge.

Troubleshooting Chart

Indication	Possible Cause	Suggested Corrective Actions
High BER	Signal strength is too low	Perform RSSI test to determine fade margin Align or change antennas or cables Ensure LOS between antennas
	Signal strength is too high	Adjust antennas Increase distance between units
	Interference	Change center frequency Increase RF power Change polarization of antennas Physically isolate antenna from source of interference or change physical location of antenna
	Bad radio (Tx/Rx)	Bench test radio Exchange radio
	Bad antenna	Visually inspect antenna for damage Sweep antenna Replace antenna
	Bad cable	Visually inspect cable Replace cable
	Bad connectors	Visually inspect connectors Replace cable/connectors
	Noisy power supply	Replace power supply unit
Low signal strength/ fade margin	Temperature	Determine ambient operating temperature is too high or low Increase or reduce ambient temperature.
	Bad radio	Bench test radio Replace radio
	Bad antenna	Visually inspect antenna for damage Sweep antenna Replace antenna
	Poor antenna alignment	Use RF diagnostics to re-align antenna
	Bad cable	Visually inspect cables/connectors Replace cable/connectors
	Bad surge suppressor	Use voltmeter to check for open circuit Replace surge suppressor.
	Incorrect radio configuration	Bench test radio to confirm configuration Reconfigure radio

Indication	Possible Cause	Suggested Corrective Actions
	<p>No Fresnel zone clearance</p> <p>Power supply problems</p>	<p>Increase antenna height to obtain clearance</p> <p>Relocate antenna</p> <p>Remove obstacles to LOS (line of sight)</p> <p>Use repeater base configuration</p> <p>Try a different AC circuit</p> <p>Measure the power at the AC outlet</p> <p>Measure the output from the power supply unit</p> <p>Replace the power supply unit</p>
<p>High packet loss</p>	<p>Signal strength too low</p> <p>Interference</p> <p>Multipath interference</p> <p>Temperature</p>	<p>Check for LOS between antennas</p> <p>Check for obstacles in RF path</p> <p>Check for interference</p> <p>Realign antennas</p> <p>Replace antenna</p> <p>Change center frequency</p> <p>Increase RF power</p> <p>Change polarization of antennas</p> <p>Physically isolate antenna from source of interference or change physical location of antenna</p> <p>Realign antennas</p> <p>Relocate radio/antenna</p> <p>Determine if ambient operating temperature is too high or low</p> <p>Increase or reduce ambient temperature</p>
<p>No communication between units</p>	<p>Configuration problems</p>	<p>Check the following configuration settings:</p> <p>Rank number—Each unit must have a unique rank number. Base station rank or remote rank may be incorrect</p> <p>Access code—Only units with same access code can communicate</p> <p>Scrambling code—Base station and remote units must use same scrambling codes to decode messages</p> <p>Acquisition code—All units must have same acquisition code to communicate</p> <p>Center frequency—Units must have same center frequency to communicate</p>

Indication	Possible Cause	Suggested Corrective Actions
		<p>IP address/subnet mask—Incorrectly configured IP addresses will result in units being unable to communicate</p> <p>Check that IP addresses are unique for each unit within a subnet and the correct subnet mask is being used</p>
	<p>Antenna or cable failure or damage</p>	<p>Visually inspect antenna and cables for damage</p> <p>Sweep antenna and cables</p> <p>Replace antenna or cables</p>
<p>Poor link performance</p>	<p>Polling sequence</p>	<p>Check polling round number. Higher polling round number increase the delay between polls for less active units</p>
	<p>Distance</p>	<p>Check the maximum remote distance configuration setting</p>
	<p>No LOS</p>	<p>Check LOS between antennas</p>
	<p>Excessive Bit errors and processing errors</p>	<p>Multipath interference—align or relocate antennas or radio</p>
	<p>Signal absorption</p>	<p>Check LOS for obstacles such as trees</p>
	<p>Throttling level</p>	<p>Check if throttling is correctly configured (Control throttling by enabling or disabling throttling and by modifying the throttling index)</p>
	<p>Center frequency</p>	<p>Set units from different systems in the same geographic area to different center frequencies—overlapping wavelengths from other systems will degrade performance</p>
	<p>Overpowering co-located unit</p>	<p>Output power from one unit can overpower another co-located radio, even if units operate on different channels—lower unit power</p>
<p>SNMP can't be activated</p>	<p>IP filtering configured incorrectly for SNMP</p>	<p>Change IP filtering to enable SNMP</p>
<p>New configuration will not take</p>	<p>Incorrectly upgraded software</p>	<p>Reload the software image using ftp or install new EPROMs</p>
<p>Unable to access main configuration menu</p>	<p>Invalid passwords</p>	<p>Contact Wi-LAN for information about how to re-enter your system</p> <p>Units will need to be reset</p>

Indication	Possible Cause	Suggested Corrective Actions
Unit will not operate	Faulty unit	Bench test unit
	Corrupt unit software	Reload unit software
Point-point link is too slow	Throttling level	Check if throttling is correctly configured
	Center frequency	Set units from different systems in the same geographic area to different center frequencies—overlapping wavelengths from other systems will degrade performance
	Overpowering co-located unit	Output power from one unit can overpower another co-located radio, even if units operate on different channels Lower the power of the unit

Appendix A: Planning Your Wireless Link

To ensure an effective and reliable wireless link, you first need to perform some network planning. This section provides some general guidelines for planning a wireless link, including the following:

- Planning the physical layout of your system
- Determining antenna and cable requirements
- Determining configuration settings for units
- Calculating a link budget

Planning the Physical Layout

You need to plan the physical layout of your wireless system.

- Determine the number of remotes
- Ensure LOS (line-of-sight) exists between units and determine coverage areas
- Measure the distance between the base station and each remote unit
- Consider the need for equipment shelters, electrical power and environmental requirements

Determine the Number of Remotes

Since the 12 Mbps data rate is shared between all units, the fewer the number of remote units, the faster each wireless link. Although a maximum of 1000 remotes is supported per base station, this number would result in low data rates. Instead, to ensure high data rates, Wi-LAN suggests a standard where 75 remotes can maintain constant 128 kbps communication with a base station. Since it is unlikely that all units will be active at the same time, the total number of remotes for planning purposes can be increased by a factor of three, so that a maximum of 225 (3×75) remotes per base station is recommended. This should enable all users to easily achieve 128 kbps performance.

Ensure LOS and Determine Coverage Area

Ensure the availability of a clear, LOS (line-of-sight) radio path between base station and all its remotes. Plot the coverage area of each base station on a map, and determine which base station will service which remote unit. Plan some alternate links in case base station coverage areas overlap or if physical obstacles block the radio path to some remotes.

Measure the Distance Between Units

Use a mapping method or GPS (global positioning system) to measure the distance between the base station and each remote, and check the radio path to identify any obstructions in the site path between the two antennas. Due to the high frequency and low output power permitted in the ISM bands, no obstructions can exist between the base station antenna and the remote unit antennas.

Determine Shelter, Power and Environmental Requirements

Hopper units must be located in a weatherproof environment (a room, EMS cabinet or shelter) with an ambient temperature between 0° and 40° Celsius, and humidity from 0 to 95% non-condensing. Consider building, electrical power, heating and air conditioning requirements.

Determining Antenna and Cable Requirements

If you plan to install a unit indoors, the indoor antenna shipped with the unit may be adequate. The signal from an indoor antenna can penetrate several walls, although metal obstructions or building features such as elevator shafts can deflect or inhibit radio waves. On-site testing is advised because all interiors are unique.

If you plan to install antennas outdoors you need to consider several factors.

- Ensure a clear line-of-sight radio path is available between each remote and its base station.
- Ensure that Fresnel zone clearances are met. Identify obstructions that could degrade link performance now and in the future.
- Obtain permission from building owners if you intend to install the antenna on a rooftop
- Obtain 24-hour access to antennas, cables and equipment
- Determine antenna mounting positions: the final position should be selected to enable physical shielding of the antenna at the back and sides from radio interference in the ISM band.
- Consider potential wind load and ice loading impact on the antenna
- Be aware of possible multipath effects: installing an antenna too close to reflective surfaces can cause signal problems.
- Check local regulatory restrictions, such as height, on antenna mast usage in the identified location
- Ensure that your antenna is properly grounded and installed according to local electrical codes.
- Determine transmission cable lengths and plan cable routes. Minimize the length of the coaxial cable because the longer the cable, the greater the cable losses.
- Calculate the fade margin—a minimum 15 dB fade margin is required to ensure the reliability of your wireless link.
- Determine Ethernet cable lengths and plan cable routes.

WARNING

Correct antenna installation is critical to the safe operation and performance of your system. Outdoor antennas should always be professionally installed.

More information about antennas is provided in [Antenna Basics](#), page 114.

Determining Unit Configuration Settings

Configuration settings of units should be determined before installation to ensure easy installation and to reduce installation costs. An information sheet should be prepared for each unit that specifies the basic configuration settings of that unit.

- Unit Name
- IP Address
- Subnet Mask
- Station Type
- Station Rank
- Center Frequency
- Security passwords
- Scrambling Code
- Acquisition Code
- Remote Unit RF Group

You may also specify other settings such as remote distance, IP filtering and throttling.

Calculating a Link Budget

Proper path planning ensures that each end of the RF link receives sufficient signal power to maintain the desired Bit Error Rate (BER). The effectiveness and reliability of your RF link depends on several factors.

- Antenna gain and other characteristics
- Distance between antennas and obstructions in the RF path
- Location and height of antennas
- Length and type of coaxial cable connecting the unit to the antenna

These factors are considered when you calculate your link budget. The calculation indicates, on paper, if your radio link is feasible over a given distance and path and if your RF link meets regulatory requirements. Link budgets are typically expressed in decibels (dB).

The following variables are used to calculate the link budget.

Variable	Description
System Gain	Maximum path loss that the system can support for usable data transmission
EIRP (Effective Isotropically Radiated Power)	Power radiating from an antenna taking into account the output power from the transmitter, connector losses, cable losses and antenna gain
Antenna Gain	Gain of the antenna over a dipole (dBd) or theoretical (dBi)
Propagation Loss	Signal loss experienced as it travels through the air, expressed in dB

Variable	Description
Fresnel Radius	Distance around line-of-sight that must be clear of obstacles
Cable Loss	Signal loss experienced as it passes through the coaxial cable, expressed in dB
Path Loss	Total loss from one end of the path to the other. Includes propagation losses, cable losses and any other losses that impact the system performance

Each variable is described below.

System Gain

The system gain of a radio system is the difference between the transmitted power and a receiver's sensitivity threshold. The system gain of the Hopper Plus 120-24 is calculated as follows.

Formula: System Gain = Transmission Power - Receiver Sensitivity @ 10^{-6} BER

Variables: Tx Power = 20 dBm
Receiver Sensitivity = -81 dBm (receiver sensitivity @ 10^{-6} BER)

Calculation: 20dBm - (-81) dBm = 101 dB

To ensure reliable communications, the system gain plus all antenna gains must be greater than the sum of all losses. For a reliable link, Wi-LAN recommends that the system gain plus all antenna gains be greater than the sum of all losses by 15 dB. This amount is the fade margin.

EIRP (Effective Isotropically Radiated Power)

EIRP is the power that radiates from an antenna, taking into account the output power from the transmitter, the connector and cable losses, and the antenna gain. Unlike the Tx output power of the devices, EIRP takes account of antenna gain and cable losses. Antennas use directional gain to increase the effective radiated power. Losses such as cable losses reduce the effective radiated power.

You calculate the EIRP as follows.

Formula: EIRP = Tx Power (dBm) - Cable Losses (dB) - Connector Losses (dB) + Antenna Gain (dBi)

Note: The FCC regulatory body has set the EIRP limit to +36 dBm for point-to-multipoint applications per FCC 15.247(b)(3)(i). For point-to-point applications, the FCC EIRP can be 3 dB higher than +36 dBm for every 1 dB less Tx power below 30 dBm.

Industry Canada specifies the EIRP limit to $\leq +36$ dBm as per RSS-210, 6.2.2(p).

In accordance with ETS 300-328 for 2.4 GHz RLANs, the maximum EIRP shall not exceed +20 dBm, with a maximum SPD (Spectral Power Density) not exceeding +10 dBm/MHz. Confirmation is required with the relevant European national radio communications local authority for deviations from this specification.

Antenna Gain

To ensure the best range and interference suppression, the external antenna should be directional, focusing the radio energy in one direction (toward the other end of the link) rather than omni-directional. Use of a directional antenna also reduces interference from other systems operating at the same frequency.

Note: In some situations, you may want to use an omni-directional antenna in your system design. For example, you would use an omni-directional antenna for a base station with remote sites situated in a 360° path around it.

When you select an antenna, pay particular attention to the gain specification. When you select an antenna for a remote station, select an antenna with a gain that provides at least 15 dB fade margin.

Antenna gain is specified in either dBi or dBd. When an antenna is specified in dBd, add 2.14 dB to the value to convert it to dBi.

Propagation Loss

Propagation loss is the attenuation (reduction) in RF signal energy as it travels through space. In most wireless systems, losses through space are the major contributor to signal attenuation. When you know the intended installation locations of the base and remote stations, determine the physical line of sight distance and then calculate the RF attenuation as follows:

Formula: Attenuation (dB) for 2.4 GHz band = $100 \text{ dB} + 20\log(d_{\text{km}})$

where:

d_{km} = Distance in Kilometers

100 dB = Pathloss Constant in the 2.4 GHz band

Fresnel Zone

It is essential that you locate your antennas at maximum above-ground height to ensure that all ground-based obstructions are cleared from the Line of Sight path and the Fresnel Zone.

The Fresnel Zone is the expansion of the RF signal radio angles in the vertical plane near the middle of the RF path.

Fresnel Zone

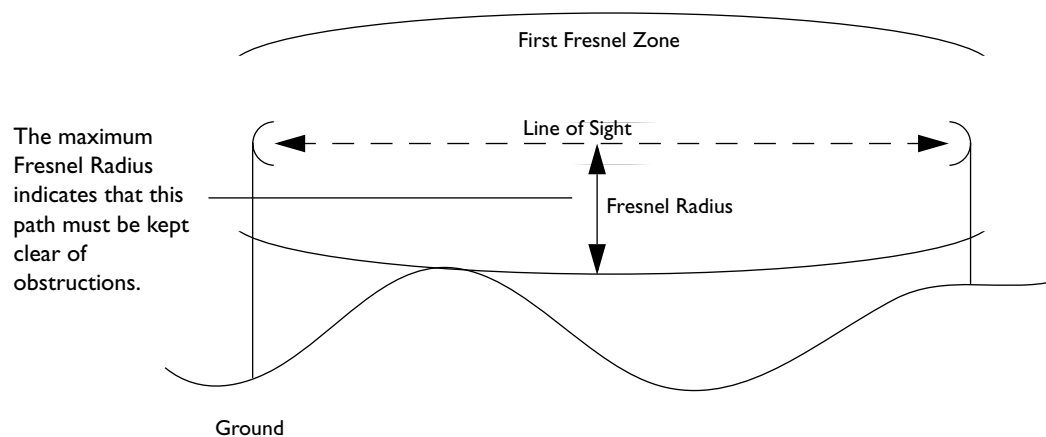

For the 2.4 GHz band, the approximate is Fresnel Radius calculated as follows.

Formula: Fresnel Radius (meters) = $3.4\sqrt{d_{km}} + (d_{km}/8.12)^2$

Cable Loss

Cable and connector losses affect the operation of the wireless link and therefore should be kept to a minimum by minimizing cable lengths and carefully selecting the type of cable. The two primary coaxial cable specifications for the Hopper Plus 120-24 are:

- Cable must be 50 ohms nominal impedance
- Cable must be of a low loss type

The following is an example of cable loss ratings at 2.4 GHz.

Cable Type	LMR400	LMR600	LDF2-50	LDF4-50A	LDF5-50A	LDF6-50
Loss (dB/meter)	0.22	0.144	0.190	0.128	0.073	0.053

Note: When you calculate path loss, you will add 1dB at each end of the link to compensate for connector losses in addition to the cable loss value.

Path Loss

Path loss describes the total RF attenuation throughout the system from Tx antenna to Rx antenna. This includes the losses as the RF signal travels through space plus Tx and Rx cable loss, and Tx and Rx connector loss. Use the following formula to calculate path loss.

Formula: Path Loss = Tx and Rx Cable Loss + Tx and Rx Connector Loss + Propagation Loss

Once you know the path loss, you can compare the value to the system gain value. If the system gain value is greater than the path loss, the link is feasible. See [System Gain](#), page 110 for more information about system gain.

Fade Margin

Fade margin is the amount by which the system gain plus the total antenna gain exceeds the path loss.

Formula: Total antenna gain = Tx Antenna Gain + Rx Antenna Gain

As calculated, the fade margin is the number of dB that the received signal strength exceeds the minimum receiver sensitivity. You require some level of fade margin for any wireless system to compensate for RF path fading due to weather conditions or multipath interference.

The Wi-LAN recommended fade margin for the Hopper Plus 120-24 is a minimum of 15 dB. The sum of the cable losses, connector losses, propagation losses, and the 15 dB required fade margin should be less than the sum of the system gain and antenna gain.

Link Budget Example

Formulas: System Gain + Antenna Gain \geq Propagation Loss + Desired Fade Margin + Cable Losses + Connector Losses

or

Actual Fade Margin \geq System Gain + Antenna Gain – Propagation Loss – Cable Losses – Connector Losses

and

Actual Fade Margin \geq Desired Fade Margin

where:

System Gain = Tx Power – Rx Sensitivity

Antenna Gains = Tx Antenna Gain + Rx Antenna Gain

Cable Losses = Base Cable Losses + Remote Cable Losses

Connector Losses = Base System Connector Losses + Remote System Connector Losses

Variables: Desired Fade Margin = 15 dB

Tx Power = 20 dBm

Rx Sensitivity = –81 dBm

Tx Antenna Gain = 21 dBi

Rx Antenna Gain = 21 dBi

Propagation Loss for desired range of 10km = $100 + 20 \times \log(10) = 120$ dB

Tx Cable Losses (5m LMR400) = $5 * 0.22 = 1.1$ dB

Rx Cable Losses (5m LMR 400)= $5 * 0.22 = 1.1$ dB

Tx Connector Losses = 1 dB

Rx Connector Losses = 1 dB

Variable System Gain = $20 - (-81) = 101$ dB

Calculations: Antenna Gains = $21 + 21 = 42$ dBi

Cable Losses = $1.1 + 1.1 = 2.2$ dB

Connector Losses = $1 + 1 = 2$ dB

Actual Fade Margin Actual Fade Margin = $101 + 42 - 120 - 2.2 - 2 = 18.8$ dB

Calculation:

Analysis: A goal of Actual Fade Margin ≥ 15 dB is achieved.

The values for cable and connector losses in this example are *only* for illustration. You will need to work these out for your specific installations.

Antenna Basics

Antennas focus and absorb radio energy in specific directions, depending on their design. Hopper Plus 120-24 antennas must be tuned to 2.40000 – 2.48350 GHz.

This section contains basic information about antenna parameters and how to select and install antennas for use in your wireless system. Antenna characteristics, mounting location, and correct operation of antennas are critical to a wireless link.

Antenna Parameters

Parameter	Description
Gain	<ul style="list-style-type: none"> Antennas have a gain associated with them, which is a measure of their ability to amplify signals in their tuned band Antenna gain is achieved by focusing the signal. A higher gain antenna has a more compressed signal
dBd vs. dBi	<ul style="list-style-type: none"> Antenna gain must be measured over a known reference and is often expressed as either dBd or dBi dBd is antenna gain referenced over a half-wave dipole which is an antenna that has a donut shaped radiation pattern dBi is antenna gain referenced over an isotropic radiator which is a theoretical antenna that radiates equally in all directions (e.g. the sun) Wi-LAN references antenna gain in dBi. The conversion factor is 0 dBd = 2.14 dBi
Beamwidth	<ul style="list-style-type: none"> Describes how a signal spreads out from the antenna, and the range of the reception area Beamwidth is measured between the points on the beam pattern at which the power density is half of the maximum power. This is often referred to as the –3 dB points A high gain antenna has a very narrow beamwidth and may be more difficult to align
Downtilt or uptilt	<ul style="list-style-type: none"> Some antennas have either an associated downtilt or an uptilt. The tilt further focuses the signal downward or upward with respect to the horizon Tilt may be either electrically built into the antenna or achieved mechanically with the mounting gear Downtilt or uptilt may be required when there is a significant deviation between the elevation of the remote site(s) and the base site
F/B	<ul style="list-style-type: none"> Front-to-back ratio Directional antennas focus the signal in a forward path. Achieved by directing the signal in one direction that reduces the signal in the opposite direction A higher gain antenna typically has a greater F/B ratio

Parameter	Description
XPD	<ul style="list-style-type: none"> • Polarity and Cross-Polarization Discrimination (XPD) • Antennas have an associated polarity, which is the orientation of the radiating element with respect to earth • Antennas are usually described as vertical, horizontal, or circularly polarized. The polarity of all antennas used in a system must be the same • Cross-Polarization Discrimination specifies the signal isolation achieved when the receiving element is perpendicular to the radiating element. Can be advantageous when co-locating radio systems
VSWR	<ul style="list-style-type: none"> • Voltage standing wave ratio • VSWR is the voltage ratio of minimum to maximum across a transmission line • A VSWR of 2.0:1 or less in an antenna is considered effective. Most antennas have a VSWR of 1.5:1 • For example, when using a radio with a 4 W output with an antenna VSWR of 1.5:1, the reflected power will be 160 mW

Implementation Considerations

Some key items to consider when selecting and installing antennas for your wireless network follow.

Item	Description
Absorption	<ul style="list-style-type: none"> • Antennas mounted too close to “soft” objects, such as trees, may experience a reduction in signal strength due to absorption • Absorption is most often encountered in applications installed during the fall or winter months, and the problem does not become evident until the spring
Diffraction	<ul style="list-style-type: none"> • Diffraction occurs when a radio signal reflects or bounces off of a solid object. • Level of diffraction could lead to connectivity problems if the remaining signal level is too low • Two types of diffraction are <i>shadowing</i> and <i>multipath</i>
Shadowing	<ul style="list-style-type: none"> • Shadowing is a form of diffraction that is typically caused when antennas are mounted too close to a structure and they lose a portion of the signal lobe due to reflection. The receive antenna is in a <i>shadowed</i> area • To minimize shadowing, ensure that there is adequate height above structures when mounting antenna equipment
Multipath Interference	<ul style="list-style-type: none"> • Multipath is a form of diffraction in which the reflected signal arrives at the receiver at different times which confuses the receiver • Multipath may be interpreted as interference by the receive antenna and can result in bit errors and processing delays

Selecting Antennas

There are several factors to consider when selecting the right antenna for a wireless application. The following are some initial questions you should ask before selecting an antenna.

- What is the operating frequency range?
- Will this be a point-to-point or point-to-multipoint application? Ensure that you consider if the application will change in the future?
- What are the coverage requirements?
- What is the gain requirement?
- What is the elevation of the remote site(s) with respect to the base station and will additional downtilt/uptilt be necessary at either the base or remote site to compensate?
- Will there be any obstructions in the path?
- Will systems be co-located? What polarity will be used?
- What are the regional environmental conditions? For example, is there windloading, salt air, excessive moisture, ice buildup etc.?
- What is the antenna lifetime expectation?
- What are the site and mounting options?
- What are the restrictions in the locale regarding the effective radiated power permitted from the antenna?
- Will antenna appearance be a factor?

Wi-LAN's Antenna Selection

The following are some antenna selections for the Wi-LAN Hopper Plus 120-24 product.

Antenna Type	Frequency	Gain
Omni	2.4 GHz	6, 9, 12
Dish	2.4 GHz	18, 19, 21, 24, 27
Planar	2.4 GHz	11, 13, 16, 17, 20

Antenna Installation Factors

Some factors you should consider when installing antennas into your wireless system are listed below.

Factor	Description
Maximizing the Hopper Plus 120-24's Capabilities	<ul style="list-style-type: none"> • Minimize obstructions in the radio path • Line Of Sight (LOS) is crucial for reliability • Ensure that equipment is installed correctly • Ensure proper grounding, testing, and alignment of antennas • Install in environmental conditions that are suitable for the Hopper unit • Select proper antennas and cable for the application • Ensure sufficient gain for the intended application
Safety	<ul style="list-style-type: none"> • Proper grounding of antenna apparatus in accordance with respective Electrical Code(s) is crucial • Wi-LAN recommends using a surge arrestor where the antenna cable enters the building • All installations should be completed by a qualified and competent RF technical
EIRP	<ul style="list-style-type: none"> • Effective Isotropically Radiated Power (EIRP) • EIRP is the amount of power that is transmitted to the air from the antenna • EIRP levels depend on the power of the radio transmitter, the size of the antenna, and the losses incurred in the antenna cable • To remain license-exempt the EIRP must remain under 4W or 36 dBm in Canada and the United States for point-to-multipoint applications. In Europe, this value is reduced to 100 mW or 20 dBm. <p>Note: $EIRP = Power\ out\ of\ unit - Power\ lost\ in\ cable + Gain\ in\ power\ from\ Antenna$</p>
Fade Margin	See Calculating a Link Budget , page 109
LOS	<ul style="list-style-type: none"> • Line of Sight (LOS) • LOS is a football shaped pattern known as the Fresnel Zone, which must be kept clear of obstructions. See Fresnel Zone, page 111 for more information • Visual line of sight must be achieved. When standing at the antenna position, you must be able to see the remote antenna

Minimal Clearance Above Obstructions

For the Hopper Plus 120-24, the absolute minimum clearance above obstructions requirements are as follows (in meters):

$$3.4m \times \sqrt{d_{km}} \text{ @ } 2.4 \text{ GHz}$$

Some example clearance requirements for 2.4 GHz links follow.

Distance (km)	Clearance (m)	Distance (miles)	Clearance (ft)
0.5	2.4	0.5	10.0
1	3.4	1	14.3
2	4.9	2	20.5
3	6.0	3	25.7
5	8.0	5	34.9
8	10.6	8	48.3
10	12.3	10	57.6
15	16.6	15	83.8

Note: There is also a correction factor to compensate for curvature of the earth. This correction factor is not required when the correction value is negligible < 10 km.

Installing Antennas

Outdoor antennas must be installed professionally to ensure that the antenna operates properly and follows accepted safety, electrical, grounding and civil engineering standards.

Ensure the following conditions.

- Dipole antennas are oriented vertically (point up).
- Antennas for the system have the same polarity (vertical, horizontal or circular).
- Connectors attaching the coaxial cable to the antenna are properly weatherproofed.
- A drip loop is formed at the building entrance to prevent water flowing down the coaxial cable and entering the installation building.
- The coaxial cable is secured to the supporting structure at one meter intervals to prevent wind damage and frost loading problems.
- The antenna is firmly attached to the mast to prevent it from falling, yet has some flexibility so you can move the antenna to fine-tune its position.
- The coaxial cable is connected to the antenna and to the ANTENNA port on both sides of the link (base and remote stations).
- Antennas are grounded properly.

Fine-tuning Antennas

You can fine-tune the antennas by physically moving the antenna. When the remote antenna is correctly aligned, the AIR LED is orange, indicating communication with the base station. You can use the Receive and Transmit Tests to test the link while adjusting the antennas to minimize BER and lost packets and maximize received power. You can use the RSSI Test to maximize RSSI.

Once antennas are adjusted to maximize performance, secure them properly to the support structures.

Co-locating Units

When Hopper Plus antennas are located on the same mast, you must take care to ensure the output power from one radio does not overpower another co-located bridge, even if the units are operating on different channels. You may need to install a signal attenuator to lower transmit power, use antenna polarity to your advantage, or adjust antenna up-tilt or down-tilt. Contact Wi-LAN Technical Assistance Center for antenna and installation assistance when co-locating units.

Appendix B: Using HyperTerminal

The Windows 95/98 operating system includes a terminal emulation program called HyperTerminal®. You can use this program to access the Hopper Plus 120-24 configuration menus through the MANAGEMENT port on the front of the unit.

Starting HyperTerminal

To start HyperTerminal

1. In Windows 95 or 98, from the **Start** menu, select **Programs, Accessories, Communications, HyperTerminal**. The Connection Description window is displayed.

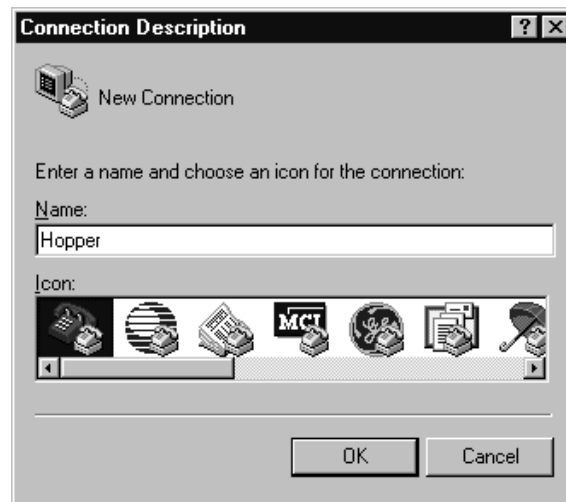

2. Select an icon for the HyperTerminal session and type a connection name.

3. Click **OK**. The Connect To window is displayed.



4. In the Connect using field, select the appropriate COM port.

5. Click **OK**. The COM Properties window is displayed.

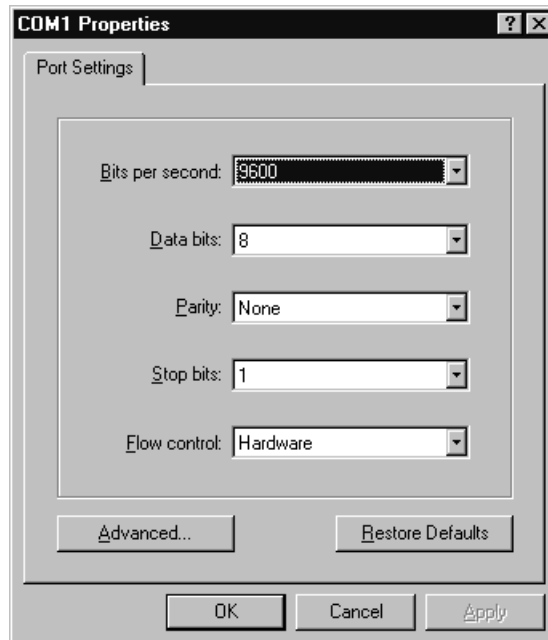

6. Enter the following settings.

Bits per second	9600
Data bits	8
Parity	None
Stop bits	1
Flow control	None

7. Click **OK**. The Hopper - HyperTerminal window is displayed.

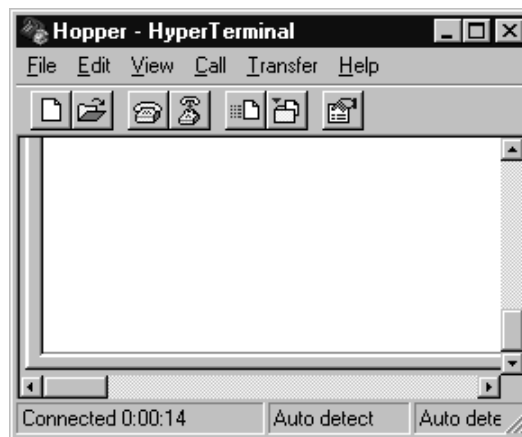

8. From the File menu, select **Properties**. The Hopper Properties window is displayed.

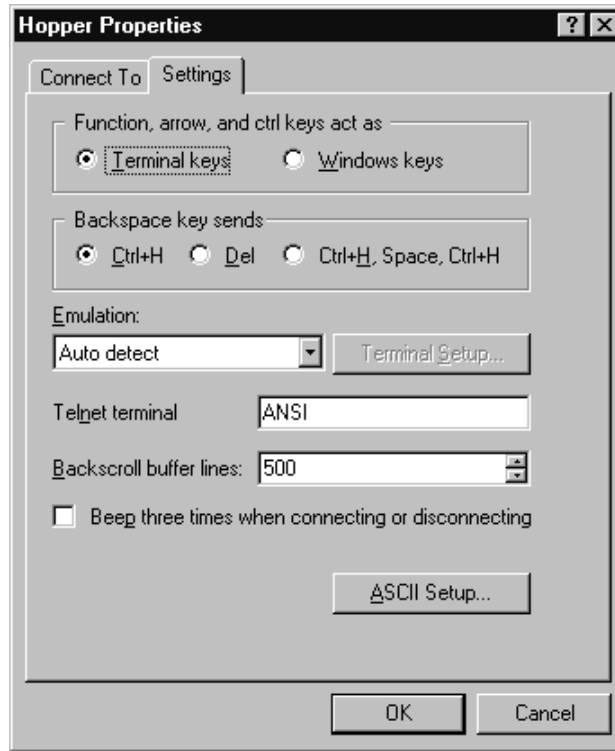

9. Click the **Settings** tab and then click **ASCII Setup**. The ASCII Setup window is displayed.

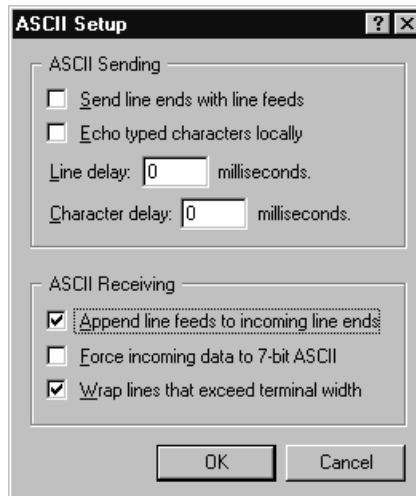

10. In the ASCII Sending area, choose the following settings.

Send line ends with line feeds	Clear the checkbox
Echo typed characters locally	Clear the checkbox
Line delay	Type 0
Character delay	Type 0

11. In the ASCII Receiving area, do the following.

Append line feeds to incoming line ends	Click to select the checkbox
Force incoming data to 7-bit ASCII	Clear the checkbox
Wrap lines that exceed terminal width	Click to select the checkbox

12. Click **OK**. The ASCII Setup window closes.
13. Click **OK**. The Hopper Properties window closes.
14. Use a cross-connect RS-232 serial cable to connect the communications port of the PC to the DB9 connector on the Hopper Plus unit.
15. Power up the unit.
16. Press **Enter**. The Configuration menu is displayed in the HyperTerminal window.

Determining the Communications Port

To set the communications port in the HyperTerminal session, you need to know which communications port you are using on your computer. Most laptops are connected through COM 1, but PCs can use COM 1 through 3.

To determine the communications port

1. Right-click the **My Computer** icon on your desktop and from the shortcut menu, select **Properties**. The System Properties window is displayed.

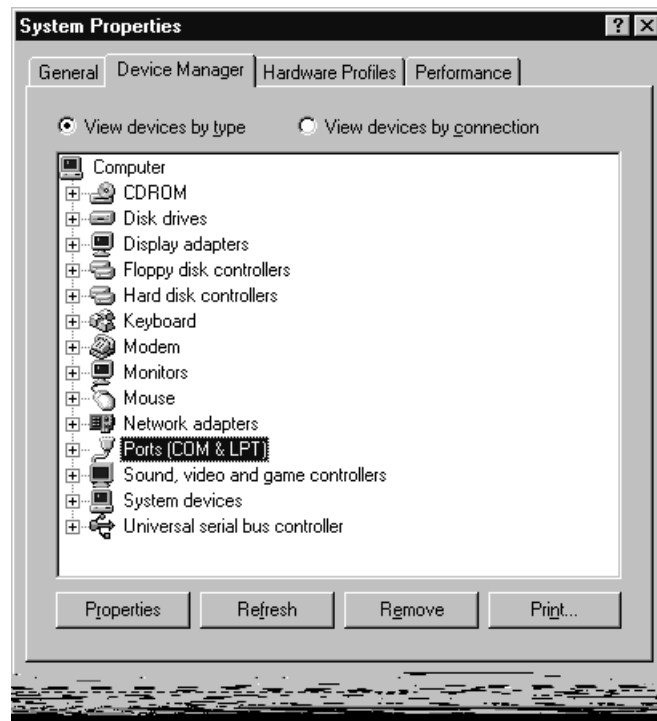

2. Click the **Device Manager** tab and click **Ports (COM & LPT)**. A list of the available communications ports appears.
3. Select the appropriate port for your HyperTerminal session.

Note: A connection to the Configuration menus will not be established if the wrong port is selected. If this occurs, reconfigure the HyperTerminal to connect using another available communications port.

Appendix C: Configuring a Simple Data Network

This section describes how to set up a simple network to perform file transfers between two computers. You need to perform the following tasks.

- Check the Network Adaptor Installation
- Configure the Network
- Enable the Sharing Feature on the Hard Disk Drive

Checking Network Adaptor Installation

To check the network adaptor installation

1. From Windows® choose the **Start** menu, select **Settings, Control Panel**. The Control Panel window is displayed.
2. Double-click the **System** icon. The System Properties window is displayed.
3. Click the **Device Manager** tab.
4. Double-click **Network Adapters**. A list of installed devices is displayed.
5. Check for trouble indicators with the previously installed network adaptor(s).
6. Click **OK**. The Control Panel window is displayed.

Configuring the Network

To configure the network

1. In the Control Panel window, double-click the **Network** icon. The Network window is displayed.

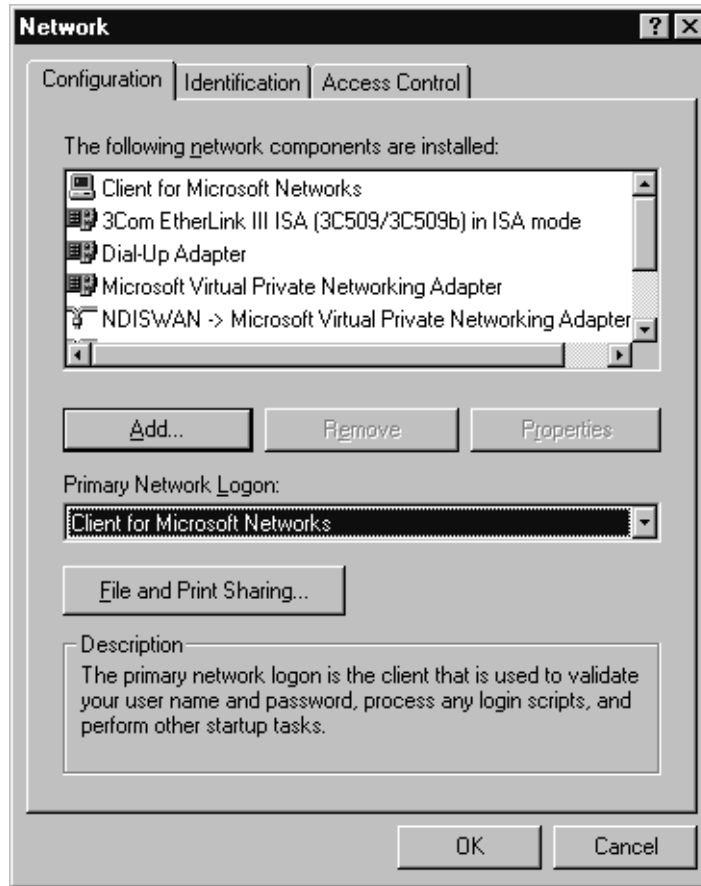

- In the list of network components area, double-click **Client for Microsoft Networks**. The Client for Microsoft Networks Properties window is displayed.

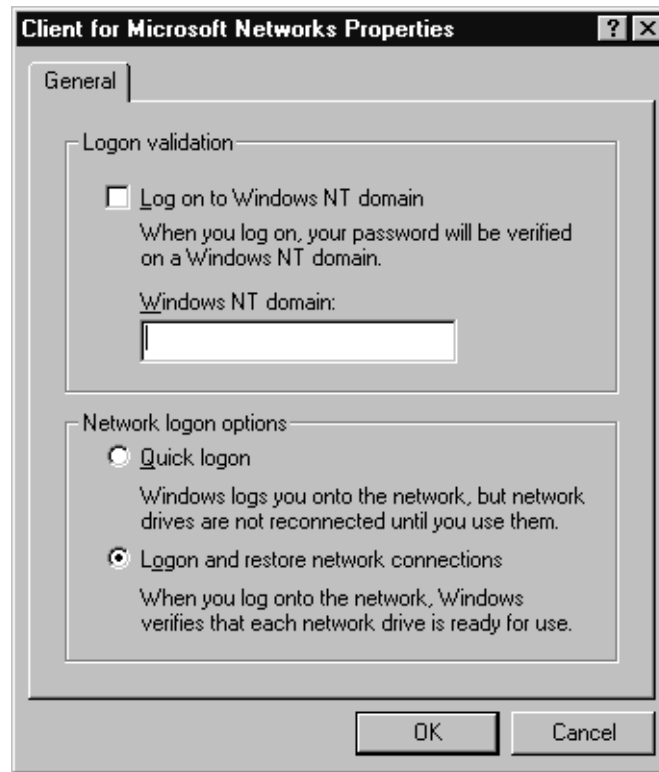

Note: If Client for Microsoft Networks is not listed, click **Add** and select **Client, Add, Microsoft, Client for Microsoft Networks**, and then click **OK**.

- In the Client for Microsoft Networks Properties window, do the following tasks.

Log on to Windows NT domain	Clear the checkbox
Windows NT domain	Clear the field
Logon and restore network connections	Click the button

- Click **OK**. The Client for Microsoft Networks Properties window closes.

5. In the Network window, double-click **TCP/IP**. The TCP/IP Properties window is displayed.

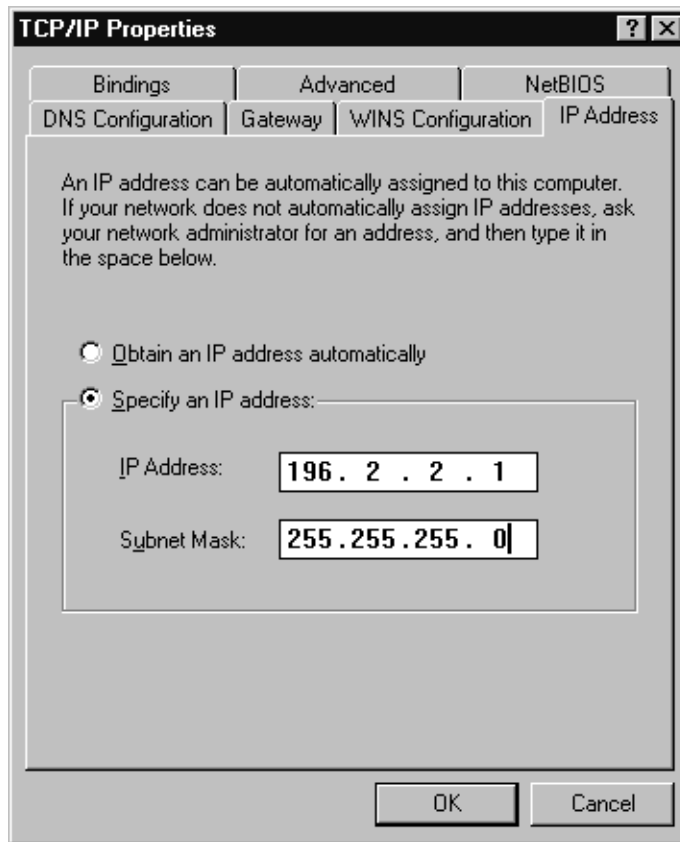

Note: If TCP/IP is not listed in the Network window, click Add and select **Protocol, Add, Microsoft, TCP/IP**, and then click **OK**.

6. Click the **IP Address** tab.
7. Click **Specify an IP Address**, and type the following.

IP Address	196.2.2.1 Note: Increment the last digit by 1 (i.e. type 196.2.2.2) when configuring the second computer
Subnet Mask	255.255.255.0 Note: This number is the same for both computers

8. Click **OK**.
9. Click **File and Print Sharing**. The File and Print Sharing window is displayed.
10. Click to select the **I want to be able to give others access to my files** checkbox.
11. Click **OK**.

12. In the Network window, click the **Identification** tab and type the following.

Computer Name	Unique name for each computer. For example, computer 1 and computer 2
Workgroup	Workgroup name. For example, Test Note: All computers in the network must have the same workgroup name
Computer Description	Description of the type of computer used. For example, laptop or desktop

13. In the Network window, click the **Access Control** tab.

14. Click **Share Level Access Control**.

15. Click **OK**.

16. You are prompted to restart your computer.

17. Click **Yes**. Wait for your computer to restart, then proceed with Enabling the Sharing Feature on the Hard Disk Drive.

Enabling the Sharing Feature on the Hard Disk Drive

To enable the sharing feature on the hard disk drive

1. On the desktop, double-click **My Computer**. The My Computer window is displayed.

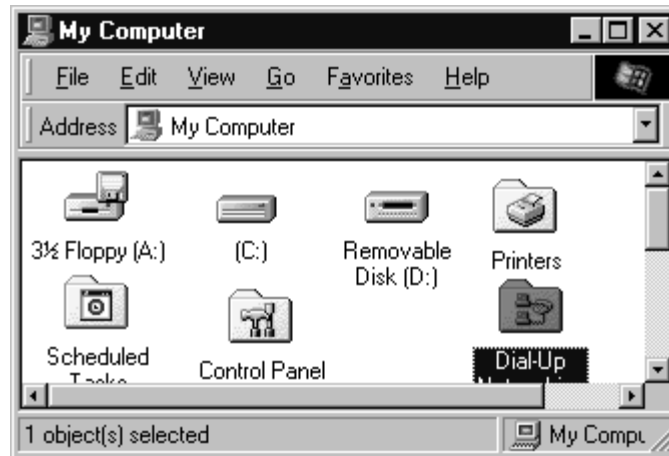

- Right-click the hard disk drive icon (typically drive C:), and select **Open**. The Properties window is displayed.

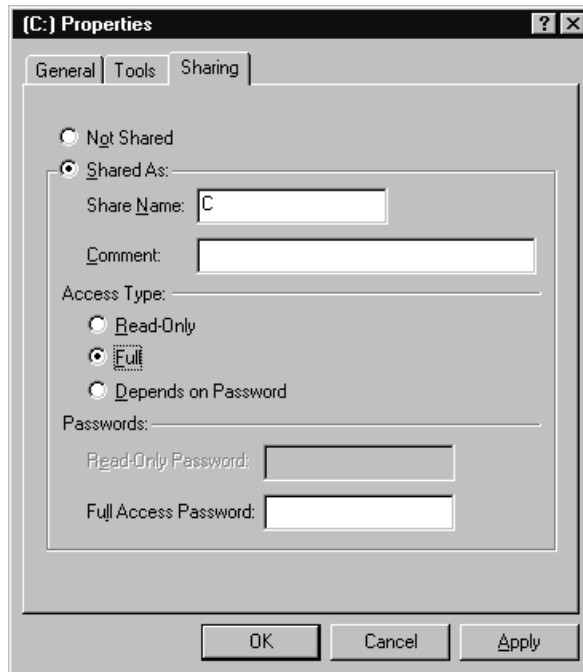

- Click the **Sharing** tab, and choose the following:

Shared As	Click the radio button
Share Name	Type C
Comment	Leave this field blank
Access Type	Click to select Full
Passwords	Leave these fields blank

- Click **OK**.
- Repeat this procedure for all PCs in the network.

Once all PCs in the network have been shared, you can view the network by double clicking the **Network Neighborhood** icon that appears on each PC desktop.

Appendix D: SNMP

About SNMP MIB

Three elements are required to use SNMP: agent software, management software and a MIB file. SNMP agent software is contained in every Hopper Plus unit. Agent software enables a unit to interpret SNMP (Simple Network Management Protocol) MIB (Management Information Block) commands.

SNMP management software is installed on a networked PC or workstation and enables a network administrator to remotely manage Hopper Plus units. If you have SNMP manager software installed on a networked PC or workstation, you can configure, monitor and control Hopper Plus units via the Ethernet or air. SNMP network management software is available commercially and as shareware (for example, you can download a free evaluation copy from www.mg-soft.com).

MIB is simply a list of objects that SNMP can monitor. You can download a proprietary Wi-LAN MIB file from www.wi-lan.com or obtain a copy through the Wi-LAN Technical Assistance Center. The Hopper Plus 120-24 is MIB version 2 compliant. After you download the MIB file, you must compile the file with the SNMP management software compiler.

SNMP Elements

SNMP Element	Description
Manager	Software installed on the network's host computer and operated by the network administrator. From the host, the Manager configures Agents or polls Agents for information
Agent	Software that runs on each unit. An Agent accepts configuration commands from the Manager and collects network and terminal information specified in the MIB
Management Information Block (MIB)	A database that is accessed by a specific set of commands and executed using the SNMP manager. There is a standard MIB and a Wi-LAN customized MIB that stores information relevant to the operation of a wireless network

Wi-LAN Object Identifier Nodes

The Hopper Plus 120-24 uses SNMP version 1, which is MIB 2 compliant. All OID (Object Identifier) nodes in the 120-24 private Wi-LAN MIB are numbered 1.3.6.1.4.1.2686.2.n where **n** is a private Wi-LAN MIB node number or branch of nodes.

All nodes containing statistical information are cleared on power up and reset.

Values in all writeable nodes are stored in Flash memory and are retained until overwritten by the administrator, even following power down or reset.

From	To	Classification
1.3.6.1.4.1.2686.2.1.1	1.3.6.1.4.1.2686.2.1.104	Configuration
1.3.6.1.4.1.2686.2.1.100.1	1.3.6.1.4.1.2686.2.1.100.7	Configuration: System Image List
1.3.6.1.4.1.2686.2.2.1	1.3.6.1.4.1.2686.2.2.7	System Status
1.3.6.1.4.1.2686.2.3.1	1.3.6.1.4.1.2686.2.3.32	Statistics
1.3.6.1.4.1.2686.2.4.1	1.3.6.1.4.1.2686.2.4.7	System Commands

Using SNMP

Refer to the documentation provided with your SNMP application software for instructions about using SNMP. The procedure for changing a unit's configuration with SNMP is described below.

To change a configuration setting with SNMP

1. Change the parameter to a new value using the appropriate SNMP command.
2. Reboot the unit with the new configuration using the **rebootNewRfConfig** node command. See [System Commands](#), page 144.
3. Save the new configuration to the unit's flash memory using the **saveConfToFlash** node command. See [System Commands](#), page 144.

Using Object Identifier Nodes

The following are descriptions of parameters and node addresses in the Hopper Plus 120-24 MIB.

Group	Parameter	Address/Node	Syntax	Access	Description
Configuration	serialNumber	1.3.6.1.4.1.2686.2.1.1	DisplayString (0..15)	Read Only	Unit Serial Number
	productionDate	1.3.6.1.4.1.2686.2.1.2	DisplayString (0..15)	Read Only	Unit Date of Manufacture
	macAddress	1.3.6.1.4.1.2686.2.1.3	PhysAddress	Read Only	Ethernet MAC Address
	systemName	1.3.6.1.4.1.2686.2.1.4	DisplayString (0..31)	Read/Write	Unit System Name
	unitLocation	1.3.6.1.4.1.2686.2.1.5	DisplayString (0..31)	Read/Write	User configurable Unit Location
	contactName	1.3.6.1.4.1.2686.2.1.6	DisplayString (0..31)	Read/Write	User configurable Contact Name
	config7	1.3.6.1.4.1.2686.2.1.7	INTEGER	Read/Write	Spare
	config8	1.3.6.1.4.1.2686.2.1.8	INTEGER	Read/Write	Spare
	config9	1.3.6.1.4.1.2686.2.1.9	INTEGER	Read/Write	Spare
	ipAddress	1.3.6.1.4.1.2686.2.1.10	IpAddress	Read Only	Internet IP Address: default = 192.168.1.100
	ipNewAddress	1.3.6.1.4.1.2686.2.1.11	IpAddress	Read/Write	New Internet IP Address
	ipSubnetMask	1.3.6.1.4.1.2686.2.1.12	IpAddress	Read/Write	IP Subnet Mask: default = 255.255.255.0
	ipGatewayAddr	1.3.6.1.4.1.2686.2.1.13	IpAddress	Read/Write	IP default gateway address (currently not used)
	ipNetmanAddr	1.3.6.1.4.1.2686.2.1.14	IpAddress	Read/Write	SNMP network management station IP address
	ipPacketFiltering	1.3.6.1.4.1.2686.2.1.15	INTEGER	Read/Write	IP packet filtering: 0 = disabled, 1 = enabled

Group	Parameter	Address/Node	Syntax	Access	Description
	ipAddressFiltering	1.3.6.1.4.1.2686.2.1.16	INTEGER	Read/Write	IP address filtering: 0 = disabled, 1 = enabled
	ipFilter1Range	1.3.6.1.4.1.2686.2.1.17	INTEGER	Read/Write	IP address filter 1 range: (0-255)
	ipFilter1Base	1.3.6.1.4.1.2686.2.1.18	IpAddress	Read/Write	IP filter 1 base address
	ipFilter2Range	1.3.6.1.4.1.2686.2.1.19	INTEGER	Read/Write	IP address filter 2 range: (0-255)
	ipFilter2Base	1.3.6.1.4.1.2686.2.1.20	IpAddress	Read/Write	IP filter 2 base address
	ipFilter3Range	1.3.6.1.4.1.2686.2.1.21	INTEGER	Read/Write	IP address filter 3 range: (0-255)
	ipFilter3Base	1.3.6.1.4.1.2686.2.1.22	IpAddress	Read/Write	IP filter 3 base address
	ipFilter4Range	1.3.6.1.4.1.2686.2.1.23	INTEGER	Read/Write	IP address filter 4 range: (0-255)
	ipFilter4Base	1.3.6.1.4.1.2686.2.1.24	IpAddress	Read/Write	IP filter 4 base address
	ipFilter5Range	1.3.6.1.4.1.2686.2.1.25	INTEGER	Read/Write	IP address filter 5 range: (0-255)
	ipFilter5Base	1.3.6.1.4.1.2686.2.1.26	IpAddress	Read/Write	IP filter 5 base address
	config27	1.3.6.1.4.1.2686.2.1.27	INTEGER	Read/Write	Spare
	config28	1.3.6.1.4.1.2686.2.1.28	INTEGER	Read/Write	Spare
	config29	1.3.6.1.4.1.2686.2.1.29	INTEGER	Read/Write	Spare
	stationType	1.3.6.1.4.1.2686.2.1.30	INTEGER	Read Only	Current station type: 0 = remote, 1 = base
	stationRank	1.3.6.1.4.1.2686.2.1.31	INTEGER	Read Only	Current station RF rank: 1 to 1000

Group	Parameter	Address/Node	Syntax	Access	Description																				
	centerFreq	1.3.6.1.4.1.2686.2.1.32	INTEGER	Read Only	Current RF center frequency																				
					<table border="1"> <thead> <tr> <th>Channel</th> <th>Frequency (GHz)</th> <th>Channel</th> <th>Frequency (GHz)</th> </tr> </thead> <tbody> <tr> <td>1</td> <td>2.4258</td> <td>5</td> <td>2.4455</td> </tr> <tr> <td>2</td> <td>2.4302</td> <td>6</td> <td>2.4498</td> </tr> <tr> <td>3</td> <td>2.4345</td> <td>7</td> <td>2.4542</td> </tr> <tr> <td>4</td> <td>2.4400</td> <td></td> <td></td> </tr> </tbody> </table>	Channel	Frequency (GHz)	Channel	Frequency (GHz)	1	2.4258	5	2.4455	2	2.4302	6	2.4498	3	2.4345	7	2.4542	4	2.4400		
Channel	Frequency (GHz)	Channel	Frequency (GHz)																						
1	2.4258	5	2.4455																						
2	2.4302	6	2.4498																						
3	2.4345	7	2.4542																						
4	2.4400																								
	securityWord1	1.3.6.1.4.1.2686.2.1.33	INTEGER	Read Only	Current RF security password 1																				
	securityWord2	1.3.6.1.4.1.2686.2.1.34	INTEGER	Read Only	Current RF security password 2																				
	securityWord3	1.3.6.1.4.1.2686.2.1.35	INTEGER	Read Only	Current RF security password 3																				
	securityWord4	1.3.6.1.4.1.2686.2.1.36	INTEGER	Read Only	Current RF security password 4																				
	securityWord5	1.3.6.1.4.1.2686.2.1.37	INTEGER	Read Only	Current RF security password 5																				
	scramblingCode	1.3.6.1.4.1.2686.2.1.38	INTEGER	Read Only	Current RF scrambling code word																				
	acquisitionCode	1.3.6.1.4.1.2686.2.1.39	INTEGER	Read Only	Current RF acquisition code (0-15)																				
	configMinutes	1.3.6.1.4.1.2686.2.1.40	INTEGER	Read Only	Current RF configuration test minutes (1-120)																				
	repeaterMode	1.3.6.1.4.1.2686.2.1.41	INTEGER	Read Only	Current base station repeater mode: 0 = disabled, 1 = enabled																				
	systemType	1.3.6.1.4.1.2686.2.1.42	INTEGER	Read Only	Current base station symmetry: 0 = asymmetric, 1 = symmetric																				
	remoteGroup	1.3.6.1.4.1.2686.2.1.43	INTEGER	Read Only	Current RF group identifier: 0 = closed, 1 - 63 = special group																				
	numOfPollRounds	1.3.6.1.4.1.2686.2.1.44	INTEGER	Read/Write	Current Number of Polling Rounds (1-60)																				
	config45	1.3.6.1.4.1.2686.2.1.45	INTEGER		Spare																				

Group	Parameter	Address/Node	Syntax	Access	Description																				
	defStationType	1.3.6.1.4.1.2686.2.1.46	INTEGER	Read Only	Default Station type: 0 = remote, 1 = base																				
	defStationRank	1.3.6.1.4.1.2686.2.1.47	INTEGER	Read Only	Default Station RF Rank																				
	defCenterFreq	1.3.6.1.4.1.2686.2.1.48	INTEGER	Read Only	FLASH RF center frequency																				
					<table border="1"> <thead> <tr> <th>Channel</th> <th>Frequency (GHz)</th> <th>Channel</th> <th>Frequency (GHz)</th> </tr> </thead> <tbody> <tr> <td>1</td> <td>2.4258</td> <td>5</td> <td>2.4455</td> </tr> <tr> <td>2</td> <td>2.4302</td> <td>6</td> <td>2.4498</td> </tr> <tr> <td>3</td> <td>2.4345</td> <td>7</td> <td>2.4542</td> </tr> <tr> <td>4</td> <td>2.4400</td> <td></td> <td></td> </tr> </tbody> </table>	Channel	Frequency (GHz)	Channel	Frequency (GHz)	1	2.4258	5	2.4455	2	2.4302	6	2.4498	3	2.4345	7	2.4542	4	2.4400		
Channel	Frequency (GHz)	Channel	Frequency (GHz)																						
1	2.4258	5	2.4455																						
2	2.4302	6	2.4498																						
3	2.4345	7	2.4542																						
4	2.4400																								
	defSecurityWord1	1.3.6.1.4.1.2686.2.1.49	INTEGER	Read Only	Default RF security password 1																				
	defSecurityWord2	1.3.6.1.4.1.2686.2.1.50	INTEGER	Read Only	Default RF security password 2																				
	defSecurityWord3	1.3.6.1.4.1.2686.2.1.51	INTEGER	Read Only	Default RF security password 3																				
	defSecurityWord4	1.3.6.1.4.1.2686.2.1.52	INTEGER	Read Only	Default RF security password 4																				
	defSecurityWord5	1.3.6.1.4.1.2686.2.1.53	INTEGER	Read Only	Default RF security password 5																				
	defScramblingCode	1.3.6.1.4.1.2686.2.1.54	INTEGER	Read Only	Default RF scrambling code word																				
	defAcquisitionCode	1.3.6.1.4.1.2686.2.1.55	INTEGER	Read Only	Default RF acquisition code (0-15)																				
	defConfigMinutes	1.3.6.1.4.1.2686.2.1.56	INTEGER	Read Only	Default RF configuration test minutes (1-120)																				
	defRepeaterMode	1.3.6.1.4.1.2686.2.1.57	INTEGER	Read Only	Default base station repeater mode: 0 = disabled, 1 = enabled																				
	defSystemType	1.3.6.1.4.1.2686.2.1.58	INTEGER	Read Only	Default base station symmetry type: 0 = asymmetric, 1 = symmetric																				
	defRemoteGroup	1.3.6.1.4.1.2686.2.1.59	INTEGER	Read Only	Default RF group identifier: 0 = closed, 1 - 63 = special group																				
	defNumOfPollRounds	1.3.6.1.4.1.2686.2.1.60	INTEGER	Read/Write	Default Number of Polling Rounds (1-60)																				

Group	Parameter	Address/Node	Syntax	Access	Description																				
	config61	1.3.6.1.4.1.2686.2.1.61	INTEGER	Read/Write	Spare																				
	newStationType	1.3.6.1.4.1.2686.2.1.62	INTEGER	Read/Write	New station type: 0 = remote, 1 = base																				
	newStationRank	1.3.6.1.4.1.2686.2.1.63	INTEGER	Read/Write	New station RF rank (1-1000)																				
	newCenterFreq	1.3.6.1.4.1.2686.2.1.64	INTEGER	Read/Write	New RF center frequency																				
					<table border="1"> <thead> <tr> <th>Channel</th> <th>Frequency (GHz)</th> <th>Channel</th> <th>Frequency (GHz)</th> </tr> </thead> <tbody> <tr> <td>1</td> <td>2.4258</td> <td>5</td> <td>2.4455</td> </tr> <tr> <td>2</td> <td>2.4302</td> <td>6</td> <td>2.4498</td> </tr> <tr> <td>3</td> <td>2.4345</td> <td>7</td> <td>2.4542</td> </tr> <tr> <td>4</td> <td>2.4400</td> <td></td> <td></td> </tr> </tbody> </table>	Channel	Frequency (GHz)	Channel	Frequency (GHz)	1	2.4258	5	2.4455	2	2.4302	6	2.4498	3	2.4345	7	2.4542	4	2.4400		
Channel	Frequency (GHz)	Channel	Frequency (GHz)																						
1	2.4258	5	2.4455																						
2	2.4302	6	2.4498																						
3	2.4345	7	2.4542																						
4	2.4400																								
	newSecurityWord1	1.3.6.1.4.1.2686.2.1.65	INTEGER	Read/Write	New RF security password 1																				
	newSecurityWord2	1.3.6.1.4.1.2686.2.1.66	INTEGER	Read/Write	New RF security password 2																				
	newSecurityWord3	1.3.6.1.4.1.2686.2.1.67	INTEGER	Read/Write	New RF security password 3																				
	newSecurityWord4	1.3.6.1.4.1.2686.2.1.68	INTEGER	Read/Write	New RF security password 4																				
	newSecurityWord5	1.3.6.1.4.1.2686.2.1.69	INTEGER	Read/Write	New RF security password 5																				
	newScramblingCode	1.3.6.1.4.1.2686.2.1.70	INTEGER	Read/Write	New RF scrambling code word																				
	newAcquisitionCode	1.3.6.1.4.1.2686.2.1.71	INTEGER	Read/Write	New RF acquisition code (0-15)																				
	newConfigMinutes	1.3.6.1.4.1.2686.2.1.72	INTEGER	Read/Write	New RF configuration test minutes (1-120)																				
	newRepeaterMode	1.3.6.1.4.1.2686.2.1.73	INTEGER	Read/Write	New base station repeater mode: 0 = disabled, 1 = enabled																				
	newSystemType	1.3.6.1.4.1.2686.2.1.74	INTEGER	Read/Write	New base station symmetry type: 0 = asymmetric, 1 = symmetric																				

Group	Parameter	Address/Node	Syntax	Access	Description
	newRemoteGroup	1.3.6.1.4.1.2686.2.1.75	INTEGER	Read/Write	New RF group identifier: 0 = closed, 1 - 63 = special group
	newNumOfPollRounds	1.3.6.1.4.1.2686.2.1.76	INTEGER	Read/Write	New Number of Polling Rounds (1-60)
	config77	1.3.6.1.4.1.2686.2.1.77	INTEGER	Read/Write	Spare
	stationMode	1.3.6.1.4.1.2686.2.1.78	INTEGER	Read/Write	Operating mode: 0 = normal, 1 = Rx Test, 2 = Tx Test, 3 = RSSI Test
	rftTransmitStatus	1.3.6.1.4.1.2686.2.1.79	INTEGER	Read/Write	RF transmit status: 0 = blocked, 1 = unblocked
	linkMonitorPeriod	1.3.6.1.4.1.2686.2.1.80	INTEGER	Read/Write	Link monitor period (0-10000): 0 = disabled, 1 - 10,000 = number of data superframes per single test superframe
	testModeTimer	1.3.6.1.4.1.2686.2.1.81	INTEGER	Read/Write	Test mode timer minutes (1-1000)
	remoteDistance	1.3.6.1.4.1.2686.2.1.82	INTEGER	Read/Write	Maximum remote unit distance (km)
					Integer Distance (km) Integer Distance (km)
					1 5 7 35
					2 10 8 40
					3 15 9 45
					4 20 10 50
					5 25 11 50
					6 30 12 60
	linkMonitorRank	1.3.6.1.4.1.2686.2.1.83	INTEGER	Read/Write	Link monitor remote station rank (1-1000)
	throttleEnable	1.3.6.1.4.1.2686.2.1.84	INTEGER	Read/Write	Throttling enable: 0 = disabled, 1 = enabled

Group	Parameter	Address/Node	Syntax	Access	Description
	throttleLevel	1.3.6.1.4.1.2686.2.1.85	INTEGER	Read/Write	RF throttle level (1-50)
	config86	1.3.6.1.4.1.2686.2.1.86	INTEGER	Read/Write	Spare
	config87	1.3.6.1.4.1.2686.2.1.87	INTEGER	Read/Write	Spare
	config88	1.3.6.1.4.1.2686.2.1.88	INTEGER	Read/Write	Spare
	config89	1.3.6.1.4.1.2686.2.1.89	INTEGER	Read/Write	Spare
	communityName1	1.3.6.1.4.1.2686.2.1.90	DisplayString(0..15)	Read/Write	Read-only access community name
	communityName2	1.3.6.1.4.1.2686.2.1.91	DisplayString(0..15)	Read/Write	Read-Write access community name
	ethernetAccess	1.3.6.1.4.1.2686.2.1.92	INTEGER	Read Only	Ethernet access to local host: 0 = disabled, 1 = enabled
	wirelessAccess	1.3.6.1.4.1.2686.2.1.93	INTEGER	Read Only	Wireless access to local host: 0 = disabled, 1 = enabled
	config94	1.3.6.1.4.1.2686.2.1.94	INTEGER	Read/Write	Spare
	currentImage	1.3.6.1.4.1.2686.2.1.95	DisplayString(0..15)	Read Only	Current system image file name
	defaultImage	1.3.6.1.4.1.2686.2.1.96	DisplayString(0..15)	Read/Write	Selects specified system image file as default
	prevDefaultImage	1.3.6.1.4.1.2686.2.1.97	DisplayString(0..15)	Read Only	Previous default system image file name
	config98	1.3.6.1.4.1.2686.2.1.98	INTEGER	Read/Write	Spare
	config99	1.3.6.1.4.1.2686.2.1.99	INTEGER	Read/Write	Spare
System Image List	systemImageList	1.3.6.1.4.1.2686.2.1.100	SEQUENCE OF SystemImageEntry	not accessible	System Image List Branch
	systemImageNumber	1.3.6.1.4.1.2686.2.1.100.1	INTEGER	Read Only	System image number

Group	Parameter	Address/Node	Syntax	Access	Description
	systemImageName	1.3.6.1.4.1.2686.2.1.100.2	DisplayString(0 ..15)	Read Only	System image file name
	systemImageRevn	1.3.6.1.4.1.2686.2.1.100.3	DisplayString(0 ..15)	Read Only	System image revision identifier
	systemImageDate	1.3.6.1.4.1.2686.2.1.100.4	DisplayString(0 ..15)	Read Only	System image file date
	systemImageTime	1.3.6.1.4.1.2686.2.1.100.5	DisplayString(0 ..15)	Read Only	Time system image file was last changed
	systemImageSize	1.3.6.1.4.1.2686.2.1.100.6	INTEGER	Read Only	System image file size
	systemImageText	1.3.6.1.4.1.2686.2.1.100.7	DisplayString(0 ..15)	Read Only	System image descriptive text
	config101	1.3.6.1.4.1.2686.2.1.101	INTEGER	Read/Write	Spare
	config102	1.3.6.1.4.1.2686.2.1.102	INTEGER	Read/Write	Spare
	config103	1.3.6.1.4.1.2686.2.1.103	INTEGER	Read/Write	Spare
	config104	1.3.6.1.4.1.2686.2.1.104	INTEGER	Read/Write	Spare
System Status	totalHours	1.3.6.1.4.1.2686.2.2.1	Counter	Read Only	Cumulative run-time hours
	systemHours	1.3.6.1.4.1.2686.2.2.2	Counter	Read Only	Current run-time hours since powerup
	loginOkays	1.3.6.1.4.1.2686.2.2.3	Counter	Read Only	Number of successful logins
	loginFails	1.3.6.1.4.1.2686.2.2.4	Counter	Read Only	Number of unsuccessful login attempts
	localUser	1.3.6.1.4.1.2686.2.2.5	INTEGER	Read Only	Local user login status: 0 = none, 1 = user, 2 = supervisor
	telnetUser	1.3.6.1.4.1.2686.2.2.6	INTEGER	Read Only	Telnet user login status: 0 = none, 1 = user, 2 = supervisor
	ftpUser	1.3.6.1.4.1.2686.2.2.7	INTEGER	Read Only	FTP user login status: 0 = none, 1 = user, 2 = supervisor

Group	Parameter	Address/Node	Syntax	Access	Description
Statistics	etherRxTotalPkts	1.3.6.1.4.1.2686.2.3.1	Counter	Read Only	Total Ethernet packets received
	etherRxLocalPkts	1.3.6.1.4.1.2686.2.3.2	Counter	Read Only	Ethernet packets received for local host
	etherRxErrorPkts	1.3.6.1.4.1.2686.2.3.3	Counter	Read Only	Ethernet packets received in error
	etherRxDroppedPkts	1.3.6.1.4.1.2686.2.3.4	Counter	Read Only	Number of received Ethernet packets dropped
	etherRxDiscardPkts	1.3.6.1.4.1.2686.2.3.5	Counter	Read Only	Number of received Ethernet packets Discarded
	etherRxTotalKbytes	1.3.6.1.4.1.2686.2.3.6	Counter	Read Only	Total Ethernet KBytes received since last reset
	etherRxBcastKbytes	1.3.6.1.4.1.2686.2.3.7	Counter	Read Only	Ethernet KBytes received since last reset
	etherTxTotalPkts	1.3.6.1.4.1.2686.2.3.8	Counter	Read Only	Total Ethernet packets transmitted
	etherTxDroppedPkts	1.3.6.1.4.1.2686.2.3.9	Counter	Read Only	Ethernet transmit packets dropped
	etherTxTotalKbytes	1.3.6.1.4.1.2686.2.3.10	Counter	Read Only	Total Ethernet KBytes transmitted since last reset
	etherTxBcastKbytes	1.3.6.1.4.1.2686.2.3.11	Counter	Read Only	Ethernet broadcast KBytes transmitted since last reset
	rRxTotalPkts	1.3.6.1.4.1.2686.2.3.12	Counter	Read Only	Total received RF packets
	rRxLocalPkts	1.3.6.1.4.1.2686.2.3.13	Counter	Read Only	Total received RF packets for local host
	rRxDroppedPkts	1.3.6.1.4.1.2686.2.3.14	Counter	Read Only	Number of received RF packets dropped
	rRxDiscardedPkts	1.3.6.1.4.1.2686.2.3.15	Counter	Read Only	Number of received RF packets discarded
	rTxTotalPkts	1.3.6.1.4.1.2686.2.3.16	Counter	Read Only	Total transmitted RF packets
	rTxLocalPkts	1.3.6.1.4.1.2686.2.3.17	Counter	Read Only	Number of transmitted local RF packets
	rTxDroppedPkts	1.3.6.1.4.1.2686.2.3.18	Counter	Read Only	Number of transmitted RF packets dropped
	rRxSframeCount	1.3.6.1.4.1.2686.2.3.19	Counter	Read Only	Total RF super frames received
	rRxOverrunErrors	1.3.6.1.4.1.2686.2.3.20	Counter	Read Only	Number of RF overrun errors
rRxSframeErrors	1.3.6.1.4.1.2686.2.3.21	Counter	Read Only	Number of RF super frame control word errors	

Group	Parameter	Address/Node	Syntax	Access	Description
	rRxChecksumErrors	1.3.6.1.4.1.2686.2.3.22	Counter	Read Only	Number of RF super frame header checksum errors
	rRxPacketErrors	1.3.6.1.4.1.2686.2.3.23	Counter	Read Only	Number of RF packet control work errors
	rRxLengthErrors	1.3.6.1.4.1.2686.2.3.24	Counter	Read Only	Number of RF super frame length errors
	rTxSuperFrameCnt	1.3.6.1.4.1.2686.2.3.25	Counter	Read Only	Number of RF super frames transmitted
	rFtoIThroughput	1.3.6.1.4.1.2686.2.3.26	Counter	Read Only	Ethernet to RF throughput
	rFtoEThroughput	1.3.6.1.4.1.2686.2.3.27	Counter	Read Only	RF to Ethernet throughput
	statistics24	1.3.6.1.4.1.2686.2.3.28	Counter		Spare
	linkMonitorRankI	1.3.6.1.4.1.2686.2.3.29	INTEGER	Read Only	Link monitor remote station rank
	linkMonRtoBber	1.3.6.1.4.1.2686.2.3.30	DisplayString (0..8)	Read Only	Link monitor remote to base bit error rate
	linkMonBtoRber	1.3.6.1.4.1.2686.2.3.31	DisplayString (0..8)	Read Only	Link monitor base to remote bit error rate
	linkMonMissPktCnt	1.3.6.1.4.1.2686.2.3.32	Counter	Read Only	Link monitor missed packet count
	linMonEnvPBtoR	1.3.6.1.4.1.2686.2.3.33	INTEGER	Read Only	Link monitor base to remote envelope power
	linkMonEnvPRtoB	1.3.6.1.4.1.2686.2.3.34	INTEGER	Read Only	Link monitor remote to base envelope power
	linkMonCorrPBtoR	1.3.6.1.4.1.2686.2.3.35	INTEGER	Read Only	Link monitor base to remote correlation power
	linkMonCorrPRtoB	1.3.6.1.4.1.2686.2.3.36	INTEGER	Read Only	Link monitor remote to base correlation power
System Commands	rebootCurrent	1.3.6.1.4.1.2686.2.4.1	INTEGER	Read/Write	Reboot current system image: I = reboot
	rebootImage	1.3.6.1.4.1.2686.2.4.2	DisplayString (0..15)	Read/Write	Reboot specified system image: system image file name

Group	Parameter	Address/Node	Syntax	Access	Description
	rebootNewRfConfig	1.3.6.1.4.1.2686.2.4.3	INTEGER	Read/Write	Reboot new RF configuration: = reboot
	restFactConfReboot	1.3.6.1.4.1.2686.2.4.4	INTEGER	Read/Write	Restore factory configuration and reboot: = restore
	saveConfToFlash	1.3.6.1.4.1.2686.2.4.5	INTEGER	Read/Write	Save current configuration to flash: = save
	resetRadioStats	1.3.6.1.4.1.2686.2.4.6	INTEGER	Read/Write	Reset radio statistics: = reset
	resetEthernetStats	1.3.6.1.4.1.2686.2.4.7	INTEGER	Read/Write	Reset Ethernet statistics: = reset

Appendix E: Technical Reference Information

Front Panel LEDs

LED Type	Color	Status
AIR (in Normal Mode)	Orange	Transmitting and receiving approximately equal amounts of data over the air
	Green	Receiving data from the air
	Red	Transmitting data to the air
	Off	Listening to the air
MODE	Green	Receive test mode - RS-232 displays statistics
	Red	Continuous Transmit test mode
	Orange	RSSI test mode - measures fade margin, which is indicated by the color of the AIR LED
	Off	Normal transceiver mode
WIRE	Green	Receiving data from the wire
	Red	Transmitting data to the wire
	Orange	Transmitting and receiving data on the wire
	Off	Listening to the wire or no wire connected
POWER	Green	Power is connected to the transceiver
	Off	No power is connected to the transceiver

Note: The AIR LED and the WIRE LED are bi-color LEDs: red and green. The displayed color depends on the proportion of received data to transmitted data. The LEDs are mostly green when more data is received than transmitted, and mostly red when more data is transmitted than received. When approximately equal amounts of data are received and transmitted at the same time, the LEDs is orange, which is the color that results from combining equal amounts of red and green.

DC Power Plug Pinout

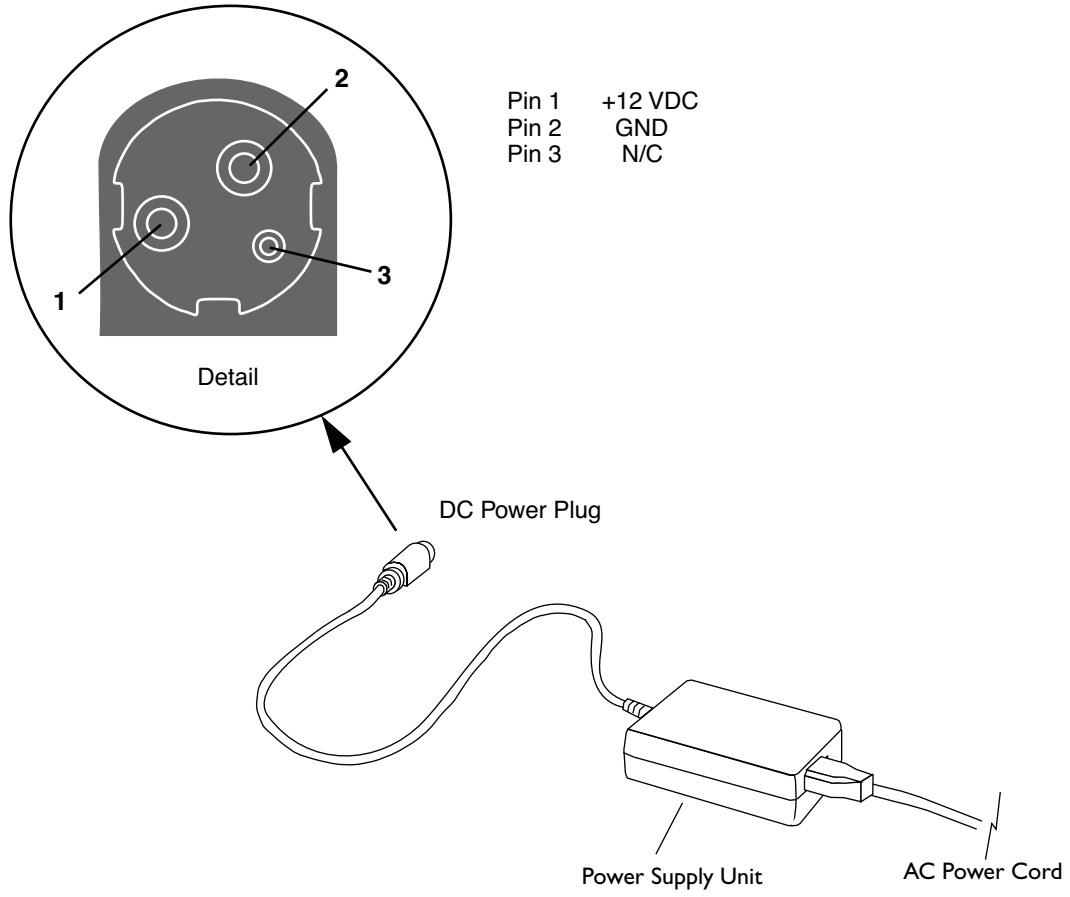

Appendix F: Menu Map

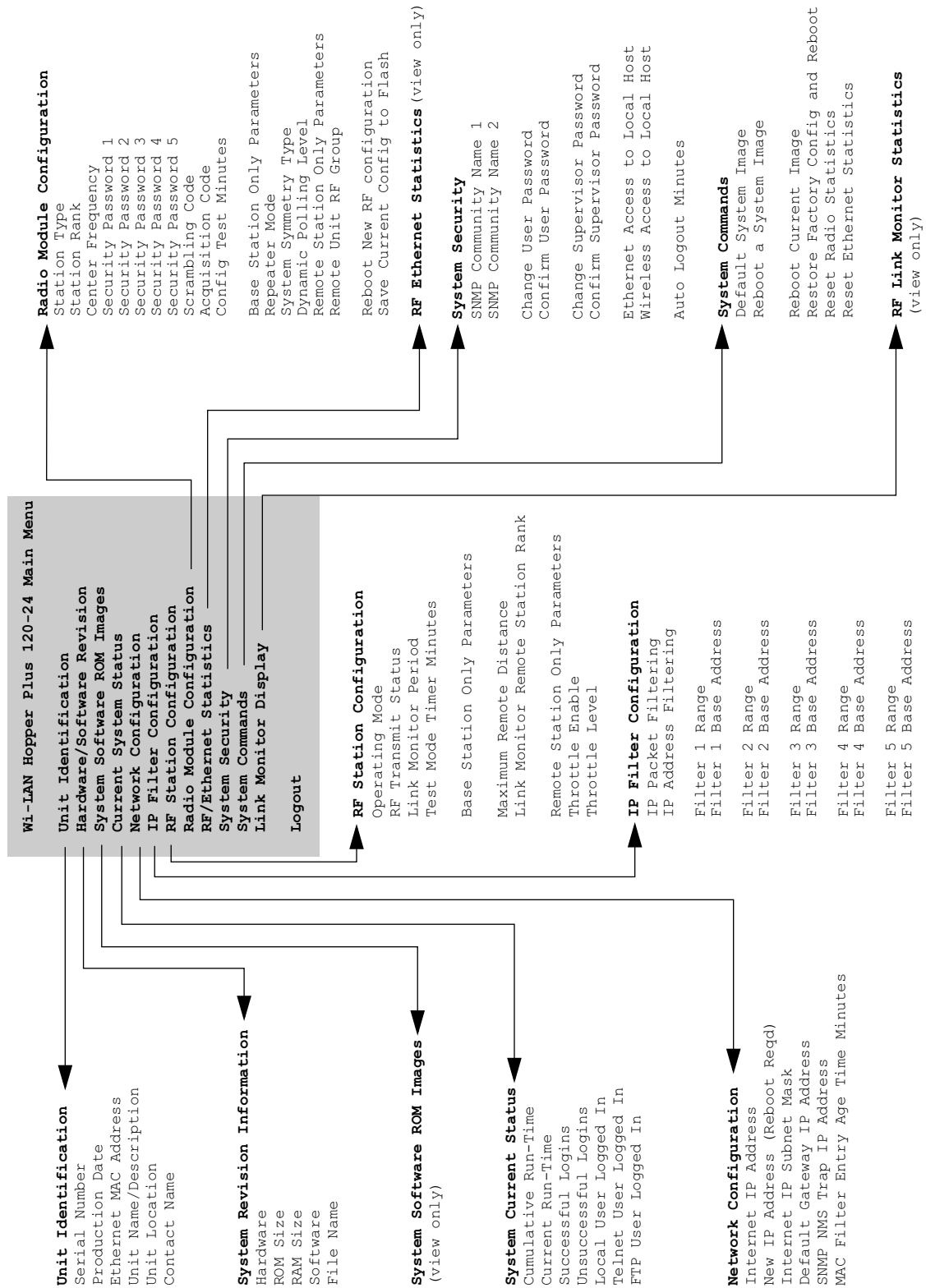

Appendix G: Upgrading Software

If necessary, you can upgrade the software of a Hopper Plus 120-24. This section explains how to use FTP to download a new software image to a Hopper unit.

Before you can download a new software image you need the following items.

- A copy of the software image file
- A PC connected to the Hopper Plus unit via the network
- Basic network software installed on your PC, including ftp, ping, telnet, SNMP manager (optional)

Obtaining New Software Images

Contact the Wi-LAN Technical Assistance Center (TAC) to acquire new image files. TAC can help determine what files you require and the most convenient way to deliver it to you. See [Contacting Wi-LAN](#), page viii.

Downloading Image Software

1. Obtain the new image files. (Image files may be delivered on floppy diskette, CD-ROM or another delivery method may be used.)
2. Open a DOS session on your PC. From Windows[®], choose **Start, Programs, MS-DOS Prompt**.
3. Copy the new image files to a known directory, for example `c:\wilan\images`. (Create a new directory if a suitable directory does not already exist.)

This directory is an example only.

```
C:> copy <image filename> c:\wilan\images
```

4. Go to the directory by typing `cd c:\wilan\images` and press **Enter**.
5. List the contents of the directory. Type `dir` and press **Enter**. The names of image files should be listed in the directory.

6. Type `ftp <IP address>` and press **Enter** where the IP address is the address of the Hopper Plus unit. The PC connects to the Hopper Plus unit.

This IP address is an example only.
Enter the IP address of your Hopper unit.

```
c:\wilan\images>ftp 192.168.3.85
Connected to 192.168.3.85
220 Wi-LAN Hopper 120-24 Ethernet Bridge FTP Server
User (192.168.3.85(none)):
```

Note: ftp must be installed on your PC.

7. Type `hopper` and press **Enter**. The password prompt appears.

```
c:\wilan\images>ftp 192.168.3.85
Connected to 192.168.3.85
220 Wi-LAN Hopper 120-24 Ethernet Bridge FTP Server
User (192.168.3.85(none)) :hopper
331 Password required
Password:
```

8. Type the supervisor password for the unit and press **Enter**. (Supervisor access is required to change Hopper unit settings—see [Setting Menu Passwords](#), page 87). The `ftp>` prompt appears.
9. After the ftp prompt, type the following "put" command.

```
ftp> put .\<image filename>
```

Note: Leave a single space after "put."

where

<code>.</code>	Current directory that contains the image file (for example, <code>c:\wilan\images</code>)
<code><image filename></code>	Name of the image file

Glossary

A

absorption

Antennas mounted too close to “soft” objects, such as trees, may experience a reduction in signal strength due to absorption. Absorption is most often encountered in applications installed during the fall or winter months. The problem does not become evident until the spring when leaves appear.

acquisition code

To minimize the effects of interference, all units in a system use the same acquisition code so the receivers can distinguish the desired signal from other interfering signals.

agent

In an SNMP context, the agent runs on each unit. An agent accepts configuration commands from the manager and collects network and terminal information specified in the MIB.

antenna

A device which accepts electromagnetic energy from a circuit or wire and radiates it into space rather than confining it.

antenna gain

Gain of the antenna over a dipole (dBd) or isotropic (dBi).

- Antennas have a gain associated with them, which is a measure of their ability to amplify signals in their tuned band.
- Antenna gain is achieved by focusing the signal. A higher gain antenna has more compressed signal.

ARP

Address Resolution Protocol. A low-level protocol that maps IP addresses to Ethernet addresses. An ARP request is sent out to the network along with an IP address. The node with the address responds to the request with a hardware address so the transmission can take place.

attenuation

Any loss in signal strength, due to resistance, absorption, capacitance or any characteristic of the medium or design of the system.

B**base station**

The central control unit of the wireless network. A base station polls remote units and controls how traffic is routed to remotes. The base usually connects to a major access point of main wired network.

beamwidth

The beamwidth of an antenna describes how a signal spreads out from the antenna as well as the range of the reception area. Beamwidth is measured between the points on the beam pattern at which the power density is half of the maximum power. This is often referred to as the -3 dB points. A high gain antenna has a very narrow beamwidth and may be more difficult to align.

BER

Bit Error Rate. A percentage of bits per million, showing the number of bits in error compared to the data bits actually sent.

blocking

Blocking is an operating mode where the radio receives only. Unblocked is the normal operating mode.

C**cable loss**

The signal loss experienced as it passes through the coax cable. Expressed in dB.

channel

The part of the spectrum band occupied by a radio signal, usually measured in kilohertz (kHz).

closed system

A system where remotes cannot communicate directly with each other. They can only communicate with each other via a base station.

coaxial cable

A type of wire where the inner conductor is surrounded by an outer conductor. The outer conductor serves as an electrical shield.

co-location

Refers to placing base stations or units in the same location. In this situation, base stations or units can interfere with each other unless steps are taken to isolate the systems from one another (such as aligning antennas or using different channels).

collision

The situation that exists when two users try to send a signal over the same medium at the same time and the signal uses the same frequencies.

configuration menus

Menus that allow the viewing and setting of Hopper Plus 120-24 parameters.

contentionless polling

A form of dynamic polling that ignores idle remote stations. The number of polls that an idle remote is ignored can be set to maximize polling to active stations.

Cross-Polarization Discrimination

See *XPD*.

D**dB**

Decibel. A relative measure of power used to specify power gains and losses. The difference in power P_1 and P_2 expressed in dB is $dB = 10 \times \log(P_1/P_2)$

DB9

A D-shaped connector with 9 pins.

dBd

dBd is antenna gain referenced over a half-wave dipole which is an antenna that has a donut shaped radiation pattern. Gain of a Standard Dipole = 2.14 dBi.

dBi

dBi is antenna gain referenced over an isotropic radiator which is a theoretical antenna that radiates equally in all directions (e.g. the sun). Wi-LAN references antenna gain in dBi. The conversion factor is: 0 dBd = 2.14 dBi.

dBm

A power measurement referenced to one milliwatt. This is an absolute measure of gain.

diffraction

Diffraction occurs when a radio signal reflects or bounces off of a solid object. The level of diffraction could lead to connectivity problems if the remaining signal level is too low. Two types of diffraction are *shadowing* and *multipath*.

downtilt

Some antennas have either an associated downtilt or an uptilt. The tilt further focuses the signal either downward or upward with respect to the horizon. A tilt may be either electrically built into the antenna or achieved mechanically with the mounting gear. An downtilt or uptilt may be required when there is a significant deviation between the elevation of the remote site(s) and the base site.

DSSS

Direct sequence spread spectrum. A method of expanding the radio signal over a broad portion of the radio band.

dynamic polling (DP)

A polling protocol in which idle units are not polled as frequently as active units. Since less time is spent polling idle remotes, there are more available resources for active units and overhead is reduced.

dynamic time allocation (DTA)

A process for determining how active a remote unit is. A unit is allowed a brief time to respond to a poll before the remote is considered idle.

E**EEPROM**

Electrically Erasable, Programmable Read Only Memory: non-volatile memory.

EIRP

Effective Isotropically Radiated Power. EIRP is the amount of power that is transmitted to the air from the antenna. EIRP levels depend on the power of the radio transmitter, the size of the antenna and the losses incurred in the antenna cable. To remain license exempt, the EIRP must remain under 4 watts or 36 dBm in Canada and the United States for point-to-multipoint applications. In Europe, this value is reduced to 100 mW or to 20 dBm.

Note: EIRP = Power out of unit – Power lost in cable + Gain in power from antenna

ERP

Effective Radiated Power. The power radiating from an antenna, taking into account the output power from the transmitter, connector losses, cable losses and the antenna gain.

ETSI

European Telecommunications Standards Institute.

F**fade margin**

The amount that the system gain plus the total antenna gain exceeds the path loss is called the fade margin. The fade margin is calculated as the number of dB that the received signal strength exceeds the minimum receiver sensitivity.

filtering

Filtering limits certain data packets or IP addresses from being passed by a unit.

FHSS

Frequency hopping spread spectrum. A method of spreading a narrowband signal across a wide radio band by "hopping" the signal as a function of time.

Flash memory

A type of electrically erasable non-volatile memory that can easily be erased without removal from a unit.

fresnel zone

The zone around the line of sight between two antennas. It consists of one of a (theoretically infinite) number of a concentric ellipsoids of revolution that define volumes in the radiation pattern of a (usually) circular aperture.

front to back ratio (F/B)

Directional antennas focus the signal in a forward path. This is achieved by directing the signal in one direction that reduces the signal in the opposite direction. A higher gain antenna typically has a greater F/B ratio.

ftp

File transfer protocol. A network utility program for moving files between nodes.

G**gain**

The ability of a device to amplify a signal. Gain is the ratio of output power divided by input power, usually expressed in decibels (dB). Gain can also be measured as an absolute value, referenced to an input signal of 1 mW (dBm). For antennas, gain measures the ability of an antenna to focus a signal and is expressed in dBd (half-wave dipole reference) or dBi (isotropic radiator reference).

gateway

The access point between one LAN and another LAN that would otherwise be incompatible with each other. It is usually a hardware device that steers communication between networks while performing code and protocol conversions.

I**IEEE**

Institute of Electrical and Electronics Engineers.

image

An image is a collection of configurations or settings for a particular device. With the Hopper Plus 120-24, the System Image File contains a collection of configurations that are used when the unit is rebooted.

interference

Any signal that tends to hamper the normal reception of a desired signal. Equivalent to jamming except considered non-hostile in origin.

IP Address

A number assigned to a network node, domain or subdivision. The number consists of four numbers—the first two numbers identify the network and subnetwork and the last two numbers identify unique nodes in the network.

ISM

Industrial, Scientific, and Medical. It consists of three license-exempt radio bands in North America and some European countries. It is also referred to as part 15.247 in the FCC regulation that defines the parameters for use of the ISM band in the U.S., including power outputs, spread-spectrum, and noninterference.

L**link monitor**

A Hopper Plus 120-24 utility that sends known data over an active system to test the reliability of the RF link. The link monitor information is overhead, that is, it reduces the amount of available payload for message data.

LOS (Line of Sight)

A clear, visual line of sight between antennas. When standing at the antenna position, you must be able to see the remote antenna. An elliptical pattern around the line of site, known as the Fresnel Zone, must be kept free of obstructions

M**MAC address**

Media Access Control address. Alphanumeric characters that uniquely identify a network-connected device. To prevent unnecessary traffic over a radio channel, units automatically learn the MAC addresses of equipment connected to the local Ethernet segment and do not transmit over the radio channel if the destination is local. A packet entering a subscriber unit from the radio port is not sent to the Ethernet port unless the destination MAC address has been learned from packets entering the Ethernet port.

manager

When used in SNMP, this element is installed on the network's host computer and is controlled by the network administrator. From the host, the manager configures agents or polls agents for information.

MIB

Management Information Block. The MIB is a database which is accessed by a specific set of commands that you can execute using the SNMP Manager. There is a standard MIB and a Wi-LAN customized MIB that stores information relevant to the operation of a wireless network.

multipath interference

When a radio signal is transmitted, it can reflect off of physical objects in the environment and take various paths to the receiver. As a result, the signal can arrive at a receiver at different times, confuse the receiver, and cause bit errors and processing delays.

O**OID nodes**

Object Identifier Nodes. These are the individual nodes in a MIB. See SNMP and MIB.

open system

A system where remote units can communicate directly with each other and with the base station.

overhead

Anything that reduces the payload capacity of a system is overhead, even if it serves a useful function. The link monitor data is used to determine transmission statistics, but it reduces the message carrying capacity of a wireless link and is considered overhead.

P**path loss**

The total loss from one end of the path to the other. This includes propagation losses, cable losses and any other losses that impact the system performance.

PN

Pseudo-random noise. A code used to change a narrowband signal into a spread spectrum signal.

polarization

The orientation of the radiating element of an antenna with respect to earth. The polarization of antennas is usually described as being vertical, horizontal or circular.

point-to-multipoint

A wireless system where one base unit communicates with many remote units. The base unit polls all the remotes and data passes between units to complete the network.

point-to-point

The simplest wireless system consisting of a base and one remote.

polling

The base unit in a Hopper Plus 120-24 point-to-multipoint system handles multiple remotes by polling each one sequentially. When a base polls a remote, data exchange between that remote and the base takes place. The remote cannot exchange information with the base until it is polled again.

propagation loss

The signal loss experienced as it travels through the air. Expressed in dB.

R**RF**

Radio Frequency. A system of communication using electromagnetic waves propagated through space. Because of varying characteristics, radio waves of different lengths are used for different purposes and are usually identified by their frequency.

remote unit

A unit that can communicate with a base station or other remote units. A remote unit forms a wireless link between a network segment and a base station.

repeater base

A repeater base rebroadcasts packets received from a remote unit to other remote units. Remote units that cannot see each other (do not have LOS) can communicate through a repeater base.

RS-232

Standards for serial communications, which define the voltages, currents, data rates and other factors about the signals to be used, as well as single-ended, differential, multi-drop operation.

RSSI

Received Signal Strength Indicator. Strength of received signal expressed in dB. The Hopper Plus 120-24 measures RSSI as a fade margin value.

S**scrambling code**

A code used to scramble messages, so that only units with the same scrambling can read the messages.

sensitivity

The minimum signal strength required for usable performance by a unit. Expressed in dBm.

shadowing

Shadowing is a form of diffraction that is typically caused when antennas are mounted too close to a structure and lose a portion of the signal lobe due to reflection. The receive antenna is in a *shadowed* area. To minimize shadowing, ensure that there is adequate height above when mounting antenna equipment to a structure.

SNMP

Simple Network Management Protocol. A protocol you can use to remotely manage a network element by polling, setting terminal values, and monitoring network statistics and events. It is the de facto internet work management standard, designed to provide a mechanism for the exchange of management information in a TCP/IP-based Internet environment.

spread spectrum (SS)

Any of a group of modulation formats in which an RF bandwidth much wider than signal bandwidth is used to transmit information, resulting in a greater immunity to noise interference.

system gain

The maximum path loss that the system can support for usable data transmission.

system image file

The Hopper Plus 120-24 uses system image files to store system configuration settings. The default system image file is called “factory-image” and is used when the Hopper Plus is first powered up.

T

telnet

An Internet communications protocol that enables a computer to function as a terminal working on a remote computer. A computer with a network connection to a Hopper Plus 120-24 can use telnet to access its configuration menus.

throttling

Throttling limits the amount of data that a remote station passes. This feature is used to improve overall system performance by adjusting the throughput of a unit to match the throughput of other devices in the network.

U

uptilt

See downtilt.

V

VSWR (Voltage Standing Wave Ratio)

VSWR is the voltage ratio of minimum to maximum across a transmission line. A VSWR of 2.0:1 or less in an antenna is considered effective. Most antennas have a VSWR of 1.5:1. For example, when using a radio with a 4 watt output with an antenna VSWR of 1.5:1, the reflected power will be 160 milliwatts.

W

W-OFDM

Wide-band orthogonal frequency division multiplexing. A method patented by Wi-LAN that divides a channel into several sub-channels, spreading the signal over the subchannels and correcting errors without having to retransmit. W-OFDM permits several independent channels to operate within the same band, enabling multipoint networks and point-to-point systems to be overlaid in the same frequency band.

X

XPD (Cross-Polarization Discrimination)

Antennas have an associated polarity, which is the orientation of the radiating element with respect to earth. Antennas are usually described as being vertically, horizontally or circularly polarized. The polarity of all antennas used in a system must be the same. XPD specifies the amount of signal isolation achieved when the receiving element is perpendicular to the radiating element. This can be advantageous when co-locating radio systems.

Index

Numerics

10/100 BaseT connector 9

A

absorption

and antennas 115

defined 155

accessing

configuration menus 32–33

acquisition code 71

configuring 71

defined 155

adding to your network 28

address

SNMP NMS trap IP address 42

administrative best practices 101

agent

defined 155

agents

SNMP 133

antennas 114–118

absorption 115

beamwidth 114

clearance requirements 118

connector 9

cross-polarization discrimination 115

dBd vs. dBi 114

defined 155

diffraction 115

downtilt 114

EIRP 117

fade margin 117

fine-tuning 119

front to back ratio 114

gain 109, 111, 114, 155

installation factors 117

installing 118

LOS 117

maximizing capabilities 117

minimal clearance 118

multipath interference 115

pre-installation 108

safety 117

selecting 116

shadowing 115

uptilt 114

voltage standing wave ratio 115

arrow keys

setting in telnet sessions 33

assembling hopper units 14

asymmetric

base station system type 74

attenuation

and antennas 111

defined 155

auto logout minutes 90

automatic logout timeout 90

B

back panel 8

LED 9

base station

defined 156

pre-configuration steps 16

repeater mode 73

setting 66

system symmetry type

asymmetric 74

symmetric 74

basic RF link 21

testing 23

basic test setup 22

beamwidth

and antennas 114

defined 156

bench test 21

- best practices 101
- bit error rate
 - defined 156
 - display in link monitor 96
- blocking
 - defined 156
- C**
- cable loss
 - and link budget variables 110
 - defined 156
- cabling 10
- calculating
 - EIRP 110
 - Fresnel radius 112
 - propagation loss 111
- center frequencies
 - configuring 68, 69
- center frequency 68
- change user password 87, 88
- changing configuration with SNMP 134
- clearance requirements
 - antennas 118
- closed system 76
- coaxial cable 156
- collision
 - defined 156
- co-located base stations, installing 28
- command line 99
- command line interface 99
- community names 86
 - setting 35
- config test timeout period 65
- configuration menus
 - accessing 32
 - navigating 32
- configuration settings
 - restoring factory configuration 94
- configuring
 - acquisition code 71
 - base station
 - maximum remote distance 60
 - repeater mode 73
 - system symmetry type 74
 - center frequencies 68, 69
 - community names 35
 - default gateway IP address 42
 - default system image file 92
 - Ethernet access 89
 - IP settings 42
 - link monitor 61
 - network configuring Hopper Plus 120-24 132
 - networks 128, 131
 - operating mode 49
 - passwords
 - login 87
 - radios 63–80
 - rank 67
 - remote access 89
 - remote station
 - RF group 78
 - throttling 62
 - scrambling code 70
 - SNMP NMS trap IP address 42
 - station type 66
 - test mode timer 51
 - timeout
 - login 90
 - unit
 - identification 35
 - name 36
- configuring with the Main Menu 34
- connecting antenna and power 15
- connecting PC to management port 16
- connectors
 - 10/100 BaseT 9
 - antenna 9
 - power supply 9
- contacting
 - Wi-LAN customer support ix
- contentionless polling 1
 - defined 157
- copyright notice vii
- Corr Power 96
- correlation power 96
 - and the link monitor display 96
- cross-polarization discrimination
 - and antennas 115
 - defined 163
- cumulative run-time 39
- current image
 - rebooting 93
- current run-time 39
- customer support ix
- D**
- dB
 - defined 157
- DB9 157
- dBd

- defined 157
- vs. dBi 114
- dBi
 - defined 157
- default
 - IP gateway address 42
 - system image file 92
- default image 92
- descriptions of units
 - base station 2
 - remote unit 2
 - repeater 2
- diffraction
 - and antennas 115
 - defined 157
- distance
 - setting maximum remote distance 60
- downtilt
 - antennas 114
 - defined 157
- DSSS
 - defined 157
- DTA 75
- dynamic time allocation 75
- dynamic polling
 - defined 157
- dynamic polling level 75
- dynamic time allocation
 - defined 158

E

EEPROM 158

EIRP

- and link budget variables 109
- antennas 117
- calculating 110
- defined 158

enabling

- sharing on hard disk 132
- throttling 62

Env Power 96

envelope power 96

- and the link monitor display 96

equipment and tools 14

ERP 158

establishing a basic RF link 21

Ethernet

- configuring access via 89
- resetting statistics 95
- viewing statistics 81

Ethernet statistics 81

ETSI 158

F

factory configuration 94

- restoring 94

fade margins 158

- and antennas 117
- measuring with RSSI mode 57

features 1

FHSS

- defined 158

field installation 27

filtering 158

filters

- enabling IP address filtering 45
- setting IP address filter range 46
- setting IP filter base address 46

fine-tuning

- antennas 119

Fresnel zone

- defined 158

- illustration 111

- radius calculation 111

front panel 7

front to back ratio

- and antennas 114

- defined 159

ftp 28

- upgrading software with 151

ftp user logged in 39

ftp, using 26

G

gain

- defined 159

gateway

- defined 159

gateway IP address

- setting default 42

general equipment setup for RF tests 50

getting help viii

guidelines for field installation 27

H

hyperterminal

- accessing menu with 32

- starting 121

I

IEEE 159

image files

rebooting current 93

setting default 92

viewing 38

installation

block diagram 13

description of block diagram 13

overview 13

installation guidelines 27

installing

antennas 117, 118

weatherproofing 108

installing units in the field 27

interference

defined 159

multipath 115

internet IP

SNMP NMS trap address 42

internet IP address 41

IP address filtering 45

IP filters 43

IP packet filtering 45

IP subnet address

setting default 41

ISM 159

L

link budgets

antenna gain 109

cable loss 110

EIRP 109

path loss 110

propagation loss 109

system gain 109

variables 109

link monitor 61–??

configuring for remote station 62

performing link monitor test 52, 53

setting link monitor period 59

setting link monitor remote station rank 61

statistics example 55

viewing link statistics when testing RF link 24

viewing statistics 96

local user logged in 39

log out of the Main Menu 97

logging in to menus

using management port 33

logging out 97

login timeout

configuring 90

logging in after 90

LOS 160

antennas 117

M

MAC address 160

main menu 31

manager 160

SNMP 133

maximum remote distance 60

MC-DSSS technology 1

menu map 149

menu passwords 87

menus

accessing 32

navigating 32

MIB

defined 160

SNMP 133

Wi-LAN nodes 134

minimal clearance

above obstructions 118

missed packet count 96

mode button 98

location on unit 9

monitor

RS-232 link monitor 51

monitoring network 29

multipath interference 115

defined 160

N

names

community 35

navigating

menus 32

network adaptor installation

checking 127

network configuring 132

network monitoring 29

network plan

obtaining the 14

network testing with ftp 28

new software images

activating 153

normal operating mode 52, 53

notices

copyright vii

O

object identifier nodes

configuration 135

statistics 143

system image list 141

system status 142

using 135

OID nodes

defined 160

Wi-LAN 134–145

open system 76

operating mode 49

configuring using menus 49, 51

original factory configuration 94

P

panel

back 8

front 7

passwords 87

path loss

and link budget variables 110

defined 161

physical layout

planning 107

ping, using 26

point-to-multipoint installation 27

point-to-multipoint system

defined 161

point-to-multipoint wireless network 3

point-to-point

defined 161

point-to-point wireless bridge 3

polarization

defined 161

polling

defined 161

power

electrical

supply connector 9

power plug pinout 148

pre-configure

pre-configuring units during installation 16

steps 16

prerequisites

antenna installation 108

network planning 107

preventative maintenance 29

product overview 1

propagation loss

and link budget variables 109

calculating 111

defined 161

put command

downloading new image files to unit 152

R

radio

configuring 63–80

resetting statistics 95

setting station type 66

specifications 10

viewing statistics 81

radio module configuration 63

rank

configuring 67

rear panel 8

reboot a unit 79

reboot current image 93

reboot image 93

rebooting 79

current image 93

new RF configuration 79

receive test 55

regulatory compliance vii

remote access

allowing 89

configuring 89

remote station

setting link monitor from 62

remote to base corr power 96

remote to base env power 96

remote unit

configuring 66

defined 161

pre-configuration steps 19

remote unit RF group 78

remote-to-remote communication 4

repeater 6

repeater base 72

repeater mode 72

repeater mode and RF group setting 77

repeater unit

defined 161

resetting

ethernet statistics 95

radio/RF statistics 95

restoring

- factory configuration settings 94
- restoring factory configuration 94
- RF
 - defined 161
 - groups 78
 - resetting statistics 95
 - viewing statistics 81
- RF group 78
- RF network planning
 - overview 107, 151
 - physical layout 107
 - prerequisites 107
- RF Station Configuration
 - normal mode 47
 - receive test 47
 - RSSI test 47
 - transmit test 47
- RF Statistics 81
- RF statistics 81
- RF test equipment setup 50
- RF transmit status 58
- ROM
 - viewing images 38
- ROM images 38
- RS-232
 - defined 162
- RSSI
 - defined 162
 - RSSI LED indicator
 - mode button 57
 - RSSI mode
 - configuring
 - with menus 51
 - with mode button 47, 56, 84, 91
- RSSI mode 57
- RSSI test 57
- S**
- safety
 - antennas 117
- save current configuration to FLASH 80
- scrambling code
 - configuring 70
- scrambling codes 70
- sectors 5, 28
- security 84
 - community names 35
 - remote access 89
 - setting login timeouts 90
 - system 35, 84
- security passwords 69
- see install 10
- selecting
 - antennas 116
- selecting operating mode with mode button 98
- sensitivity 162
- set the operating mode 49
- setting internet IP address 41
- setting VT100 arrows 33
- shadowing 115, 162
- shipping package contents 7
- simple network test 24
- simple network test setup 25
- site master test set 27
- SNMP
 - agents 133
 - defined 162
 - manager 133
 - MIB 133
 - setting community names for 35
 - setting NMS trap IP address 42
- SNMP application software 134
- SNMP NMS trap address 42
 - setting 42
- software upgrade 151
- specifications 10
 - configuration 11
 - environment 11
 - general 10
 - network support 10
 - radio 10
 - security 11
 - wireless network protocols 10
- spread spectrum
 - defined 162
- spread spectrum, MCDSS 10
- station rank 67
- station type 66
- statistics 81
 - resetting statistics 95
 - viewing Ethernet 81
 - viewing RF 81
- successful logins 39
- supervisor password 88
 - default 32
- sweeping antennas 27
- symmetric
 - base station system type 74
- system

- physical layout 107
- security 84
- system gain
 - defined 162
- system image files 91
 - setting the default 92
- system symmetry type 74

T

- Technical Assistance Center
 - contacting ix
- telnet
 - accessing units with 33
 - setting arrow keys in sessions 33
- telnet user logged in 39
- test time minutes 51
- testing
 - using the link monitor 61
- testing with a simple wireless network 24
- throttle enable 62
- throttle level 62
- throttling 62
 - configuring 62
 - defined 163
- timeouts
 - login 90
- timer
 - test mode 51
- tools and equipment 14
- transmit or receive tests 55
- transmit test 55
- trap address 42
- troubleshooting viii, 102
- troubleshooting areas 102
- troubleshooting chart 103

U

- unit
 - identification 35
 - name 36
- unit identification
 - contact name 35
 - MAC address 35
 - production date 35
 - serial number 35
 - unit location 35
 - unit name/description 35
- unsuccessful logins 39
- upgrading software 151
- uptilt

- antennas 114
 - defined 163
- user password 87
 - default 32

V

- variables
 - link budgets 109
- view link monitor rank 96
- view missed packet count 96
- view remote to base BER 96
- viewing
 - current radio module configuration 63
 - current system status 39
 - Ethernet statistics 81
 - IP addresses 40
 - link monitor statistics 96
 - radio/RF statistics 81
 - subnet mask 40
 - system revision information 37
 - system software ROM images 38
- voltage standing wave ratio
 - and antennas 115
 - defined 163
- VT100 arrows 33

W

- WAN
 - system configuration 32
- weatherproofing 108
- Wi-LAN
 - contacting viii
- wireless
 - configuring access via 89
- wireless bridge 3
- W-OFDM
 - defined 163

Product Code: 5700-0037

Copyright© DEC 2000 Rev 02

We are interested in your comments.

Please contact us by email at docfeedback@wi-lan.com if you have any comments about this user guide.



www.wi-lan.com

