



Cables and Connectors

This appendix describes specifications for different facets of the MAX, and discusses cabling requirements. This appendix covers these topics:

- [User interface specifications](#)
- [Ethernet interface specifications](#)
- [T1/PRI interface specifications](#)
- [E1/PRI interface specifications](#)
- [ISDN BRI interface specifications](#)
- [Serial host interface specifications](#)
- [Serial WAN cabling specifications](#)
- [IDSL specifications](#)

User interface specifications

This section covers cabling pinouts for the Control Monitor, Palmtop Controller, and MIF interfaces.

Control port and cabling pinouts for the Control Monitor and MIF

The Control port uses a standard DE-9 female connector that conforms to the EIA RS-232 standard for serial interfaces. [Table C-1](#) lists all MAX models that use the RS-232 pinouts.

Table C-1. Control Monitor and MIF Control port and cabling pinouts

DE-9 pin number	RS-232 signal name	Function	I/O
1	DCD	Data Carrier Detect	O
2	RD	Serial Receive Data	O
3	SD	Serial Transmit Data	I
4	DTR	Data Terminal Ready	I
5	GND	Signal Ground	
6	DSR	Data Set Ready	O
7	RTS	Request to Send	I
8	CTS	Clear to Send	O
*9	*RI	*Ring Indicator	*O

Note: *Pin 9 is not active (Ring Indication signal not supplied).

Pinouts for the Palmtop Controller

Table C-2 specifies the pins and corresponding functions of the Palmtop Controller jacks.

Table C-2. Palmtop Controller pinouts

MAX RJ12 pin	Function	I/O
1	Power to Palmtop, +5V	O
2	Control Out	O
3	Control In	I
4	Serial Transmit Data	O
5	Serial Receive Data	I
6	Ground	

Note: O is Out (from the MAX toward the Palmtop).

Palmtop port cabling pinouts for a Control Monitor

Table C-3 lists the specifications you need to adapt the Palmtop port for use as a Control Monitor or MIF interface through a vt-100 terminal.

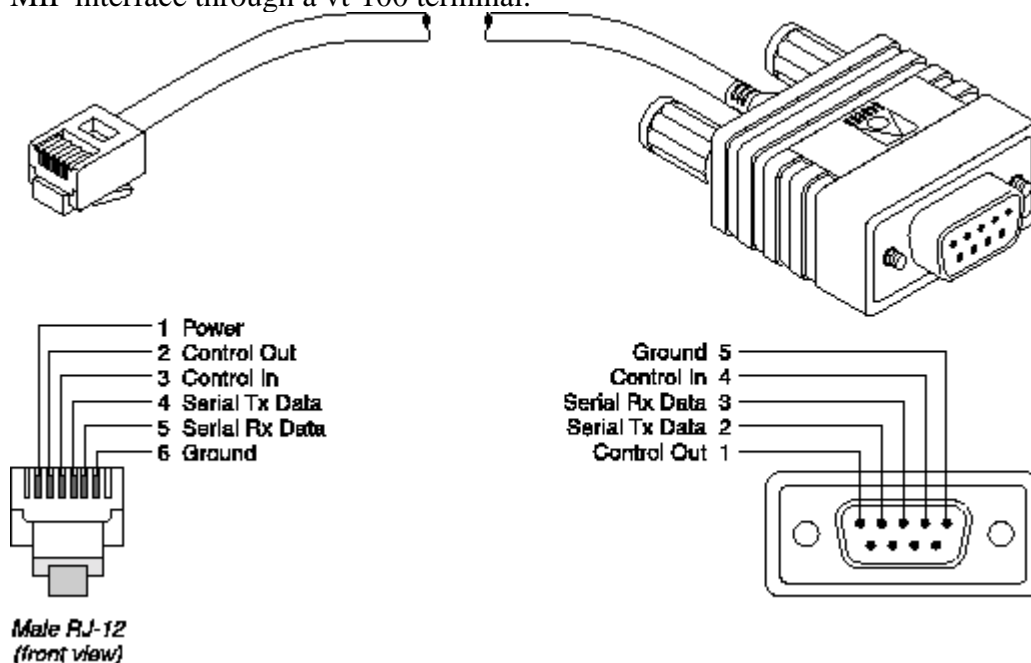

Figure C-1. Control Monitor and MIF Palmtop port and cable

Table C-3. Control Monitor and MIF Palmtop port and cabling pinouts

Model number HHT-VT-100

Part number 2510-0088-001		
Signal (MAX)	MAX RJ12 pin number	VT-100 female DE-9 pin number
Power (+5V)	1	not connected
Control Out	2	1
Control In	3	4
Serial Transmit Data	4	2
Serial Receive Data	5	3
Ground	6	5

Ethernet interface specifications

The base unit of a MAX has an Ethernet interface that supports the physical specifications of IEEE 802.3 and IEEE 802.14 with Ethernet 2 (Ethernet/DIX) framing. It provides a single Ethernet interface that auto-senses the Ethernet type to which it is connected. The following types are supported:

- 10Base-T (Unshielded Twisted Pair): Twisted pair Ethernet and IEEE 802.3 (10Base-T) with an RJ-45 connector, labeled LAN UTP.
- 100 Base-T: 100 Mbits/s Baseband Modulation on Twisted Pair

The Ethernet address used to identify the Ethernet interface resides in the MAX unit's motherboard.

Required equipment

To install the Ethernet interface, you must have either of the equipment described in the sections below.

10Base-T

You need a twisted-pair Ethernet cable and a dual twisted-pair cable terminated with RJ-45 modular jacks.

Use an EIA/TIA 568 or IEEE 802.3 10Base-T cable.

100Base-T

You need a twisted-pair Ethernet cable and a dual twisted-pair cable terminated with RJ-45 modular jacks.

Use one of the following cables: 100BASE-T2, 100BASE-T4 (not very popular), 100BASE-TX, or 100BASE-FX.

T1/PRI interface specifications

This section provides the specifications for the MAX unit's T1/PRI interface and covers cabling requirements.

T1/PRI CSU requirements

Your requirements differ depending on whether or not you enable the internal CSU on each T1/PRI port on the MAX. Enable the internal CSU by setting the Net/T1 > Line Config > Line *N* > Front End parameter to CSU. Disable the internal CSU by setting Front End to DSX.

- If you enable the internal CSU on a T1/PRI port, you can connect the port directly to the metallic interface of the WAN.

To avoid harming the WAN, you must contact your carrier for approval before installation. Once you install the MAX, you must notify the carrier before disconnecting the MAX from the WAN. If you disconnect or turn off the MAX without prior notification, the carrier might temporarily discontinue your T1/PRI service.

The MAX unit's internal CSUs are compatible with dry-loop T1/PRI lines, and with span-powered or wet-loop powered T1/PRI lines.

- If you disable the internal CSU on a T1/PRI port, you cannot connect directly to the WAN.

You must connect the port to other equipment that provides the interface to the WAN, such as an external CSU. Your carrier determines the correct setting for the line buildout setting of the CSU. You configure this parameter during installation. For more information, see the *MAX Reference Guide*.

[Table C-4](#) lists CSU specifications

Table C-4. CSU specifications

Information	Value
CSU Registration	2CZUSA-74421-DE-N
Critical Circuitry Power Source	Dry Loop from local AC power source
Line Capture Frequency	1.544 Mb/s +/- 200 b/s
Line Code	AMI or B8ZS
Line Framing	D4 or ESF
Line Input/Output Impedance	100 Ohms +/- 5%
Received Signal Level Range	DSX-1 level to -27.5 db
Transmitted Signal Level	DSX-1 level into 100 Ohms
Line Buildout	0.0, 7.5, 15.0, or 22.5 db
Pulse Density and Consecutive Zeros Enforcement	In accordance with requirements of AT&T Pub 62411
Line Loopback (LLB) Set Inband Code	(10000) repeating binary pattern
Line Loopback (LLB) Reset Inband Code	(100) repeating binary pattern

Note: During loss of power or whenever the MAX restarts, a relay closure returns the T1 PRI signal to the WAN; that is, the T1 PRI line is looped back. However, if the MAX is configured for framing-compatible drop-and-insert functionality, all channels of line #1 are passed to line #2. Note that line #1 and line #2 of a MAX expansion module always loop back on loss of power, regardless of how they are configured.

T1/PRI cable specifications

The maximum cable distance between the T1/PRI WAN interface equipment and the MAX should not exceed 655 feet (200 m) for a MAX without CSUs. Measure the line length and record it when you install the MAX. You must specify this length when you configure the Line Profile parameters. For more information, see the *MAX Reference Guide*.

Use only cables specifically constructed for transmission of T1/PRI signals. The cables should meet standard T1 attenuation and transmission requirements. The following specifications are recommended:

- 100 Ohm
- Two twisted pairs, Category 3 or better

The WAN interface cables and plugs described in the following sections are available for the MAX unit's WAN interfaces.

T1/PRI crossover cable: RJ48C/RJ48C

Install this cable when the WAN interface transmits on pins 5 and 4 and receives on pins 2 and 1. Refer to [Figure C-2](#) and [Table C-5](#).

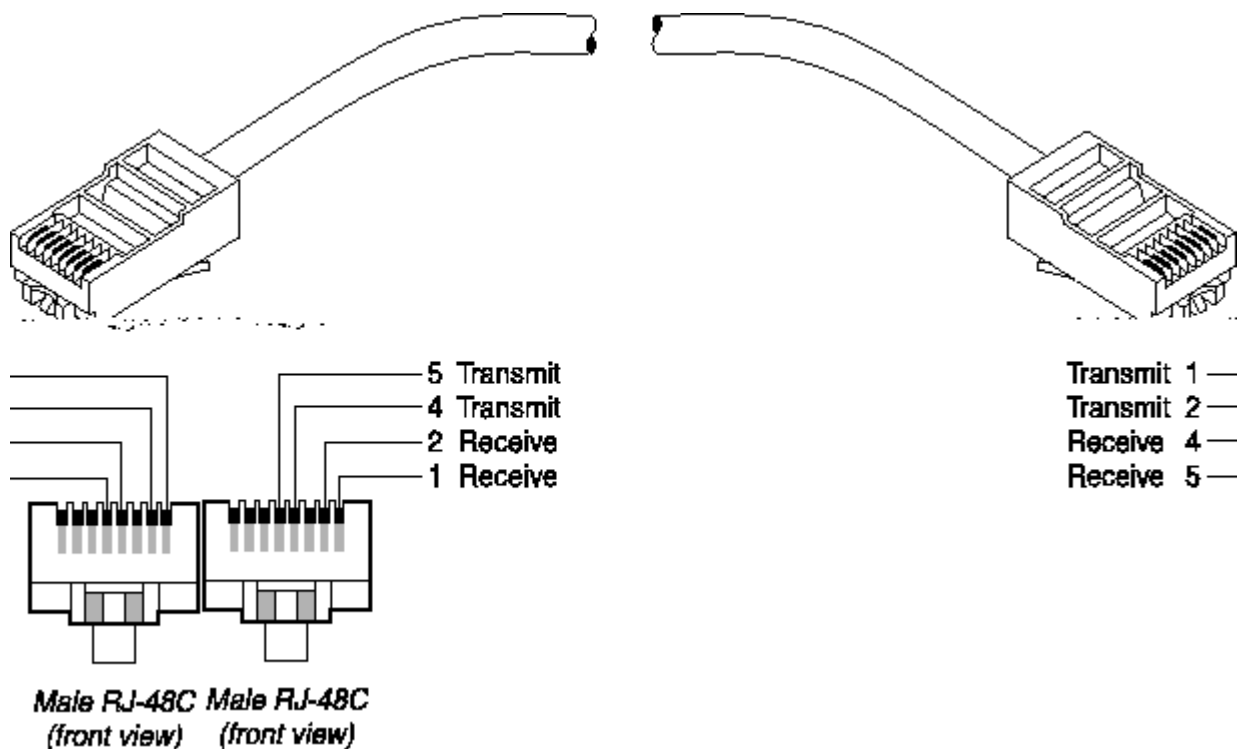

Figure C-2. RJ48C/RJ48C crossover cable

Table C-5. RJ48C/RJ48C crossover cable specifications

Model number RJ48C-X			
Part number 2510-0059/0323-001			
Pair #	Signal (MAX)	Male RJ48C (MAX)	Male RJ48C (remote)
1	Receive	2	5
		1	4



T1/PRI straight-through cable: RJ48C/RJ48C

Before installing this cable, verify that the WAN interface transmits on pins 2 and 1 and receives on pins 5 and 4. Refer to [Figure C-3](#) and [Table C-6](#).

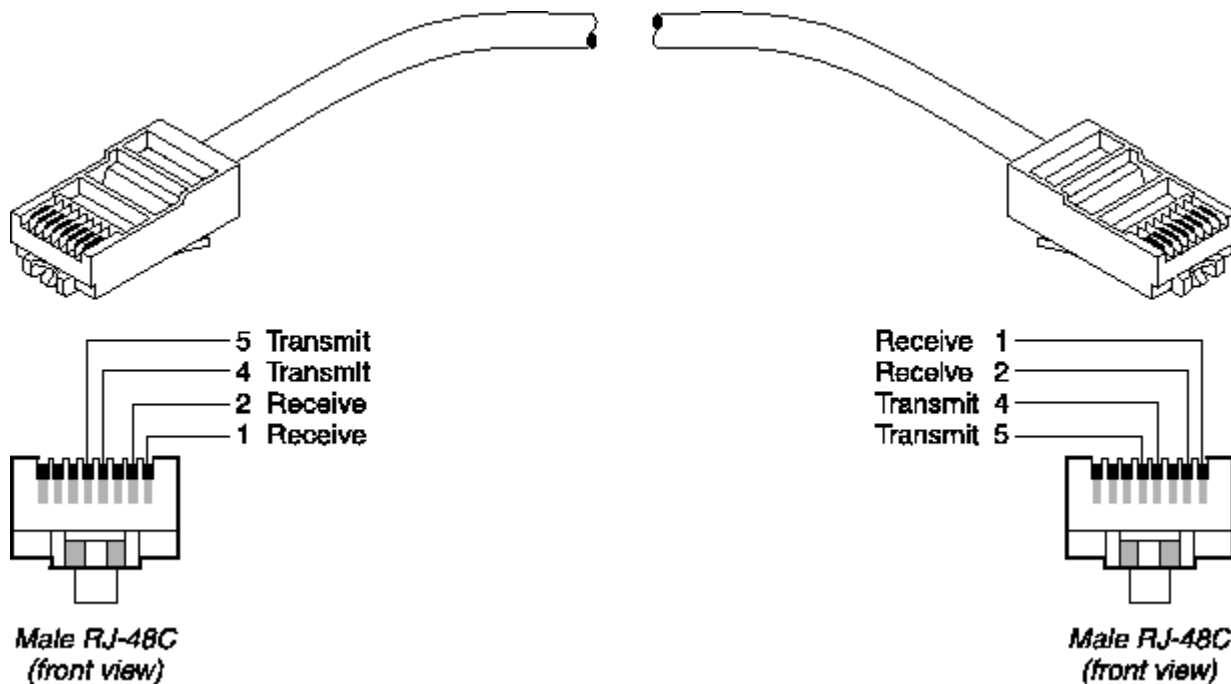

Figure C-3. RJ48C/RJ48C straight-through cable specifications
 Table C-6. RJ48C/RJ48C straight-through cable specifications

Model number RJ48C-S			
Part number 2510-0064-001			
Pair #	Signal (MAX)	Male RJ48C (MAX)	Male RJ48C (remote)
1	Receive	1	1
		2	2
2	Transmit	5	5
		4	4

T1/PRI straight-through cable: RJ48C/DA-15

Before installing this cable, verify that the WAN interface transmits on pins 3 and 11 and receives on pins 1 and 9. Refer to [Figure C-4](#) and [Table C-7](#).

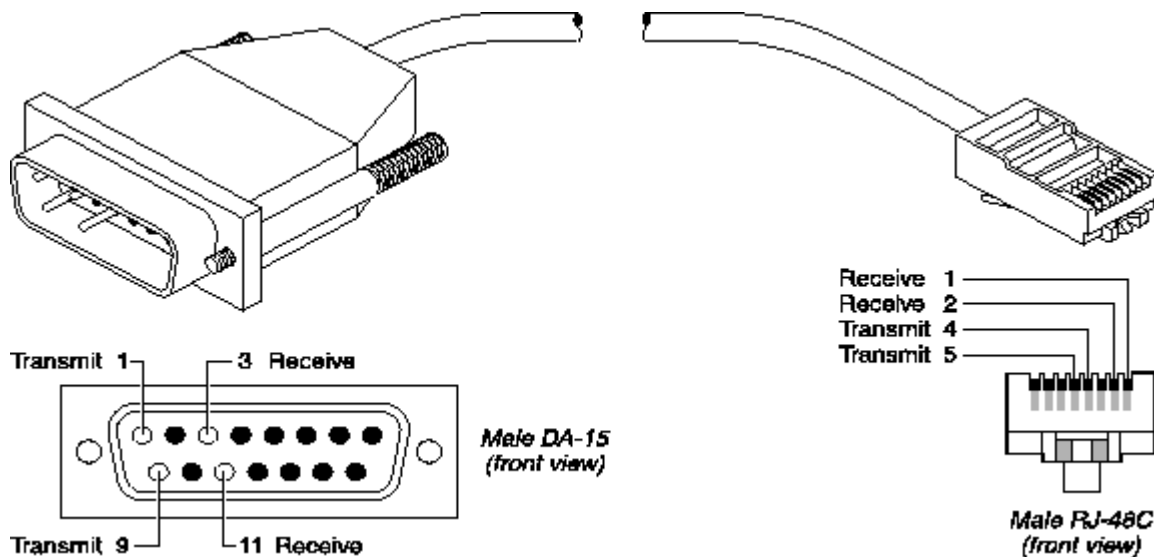

Figure C-4. RJ48C/DA-15 straight-through cable

Table C-7. RJ48C/DA-15 straight-through cable specifications

Model number DA15-X			
Part number 2510-0082-001			
Pair #	Signal (MAX)	Male RJ48C (MAX)	Male DA-15P (remote)
1	Receive	1	3
		2	11
2	Transmit	5	1
		4	9

T1/PRI crossover cable: RJ48C/DA

Before installing this cable, verify that the WAN interface transmits on pins 1 and 9 and receives on pins 3 and 11. Refer to [Figure C-5](#) and [Table C-8](#).

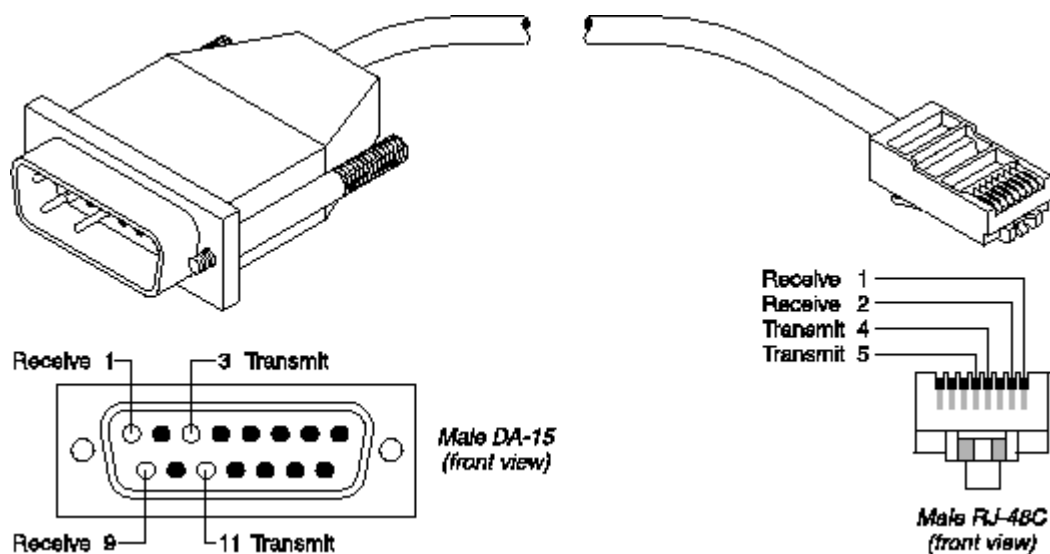

Figure C-5. RJ48C/DA crossover cable

Table C-8. RJ48C/DA crossover cable specifications

Model number DA15-S			
Part number 2510-0065-001			
Pair #	Signal (MAX)	Male RJ48C (MAX)	Male DA-15P (remote)
1	Receive	1	1
		2	9
2	Transmit	5	3
		4	11

T1/PRI straight-through cable: RJ48C/Bantam

The WAN side of the cable connects to dual bantam jacks. Refer to [Figure C-6](#) and [Table C-9](#).

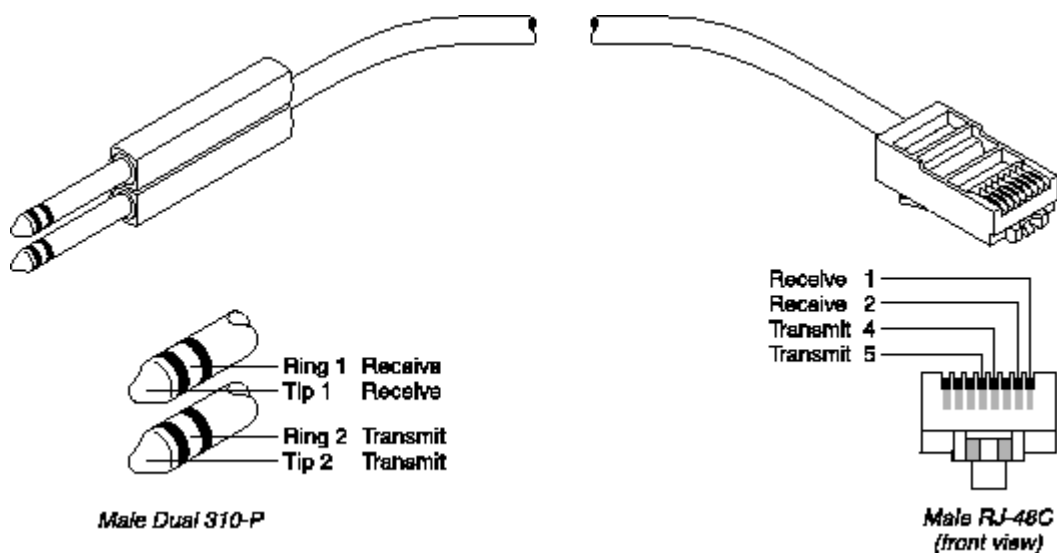

Figure C-6. RJ48C/Bantam straight-through cable

Table C-9. RJ48C/Bantam straight-through cable specifications

Model number DBNT-RJ45			
Part number 2510-0066-001			
Pair #	Signal (MAX)	Male RJ48 (MAX)	Male Dual - 310P (remote)
1	Receive	1	Tip 1
		2	Ring 1
2	Transmit	5	Tip 2
		4	Ring 2

T1 RJ48C-Loopback plug

This plug loops the transmit signal back to the MAX

Table C-10. RJ48C-Loopback
plug specifications

Pair #	Signal	Male RJ48C
1	Receive	1 (connects to 5) 2 (connects to 4)
2	Transmit	5 (connects to 1) 4 (connects to 2)

T1/PRI WAN ports

Table C-11 lists the pins on RJ48C sockets on the MAX used for T1/PRI WAN interface. Only pins 1, 2, 4, and 5 are used. The remaining pins are not connected.

Table C-11. Transmit and Receive pins

MAX T1/PRI interface	RJ48C DTE
Receive (input) pair, Tip (T1)	Position 2
Receive (input) pair, Ring (R1)	Position 1
Transmit (output) pair, Tip (T)	Position 5
Transmit (output) pair, Ring (R)	Position 4

WAN switched services available to the MAX

The MAX is compatible with both AT&T and Northern Telecom central office switches, and can access all T1/PRI switched digital services offered by AT&T's ACCUNET Switched Digital Services:

- MCI 56 kbps and 64 kbps services
- Sprint Switched 56 kbps and 64 kbps services
- MultiRate and GloBanD (and GVPN in CCITT countries) PRI network services

Note: The MAX can access only Switched-56 kbps services on a T1 access line or a Switched-56 line.

For a listing of the compatible switch types, see *the Switch Type parameter in the MAX Reference Guide*. In addition to switched circuits, the MAX can connect to nailed-up circuits, and to aggregate nailed-up and switched circuits.

E1/PRI interface specifications

This section provides the specifications for the MAX unit's E1/PRI interface and covers cabling

requirements.

During loss of power or whenever the MAX restarts, a relay closure returns the E1 PRI signal to the WAN; that is, the E1 PRI line is looped back. However, if the MAX is configured for framing-compatible drop-and-insert functionality, all channels of line #1 are passed to line #2. Note that line #1 and line #2 of a MAX Net/E1 expansion module always loop back on loss of power, regardless of how they are configured.

E1/PRI cable specifications

The WAN interface cables and plugs described in this section are available for the MAX unit's WAN interfaces. Use only the cable specifically constructed for transmission.

E1/PRI crossover cable: RJ48C/RJ48C

Install this cable when the WAN interface transmits on pins 5 and 4 and receives on pins 2 and 1. Refer to [Figure C-7](#) and [Table C-12](#).

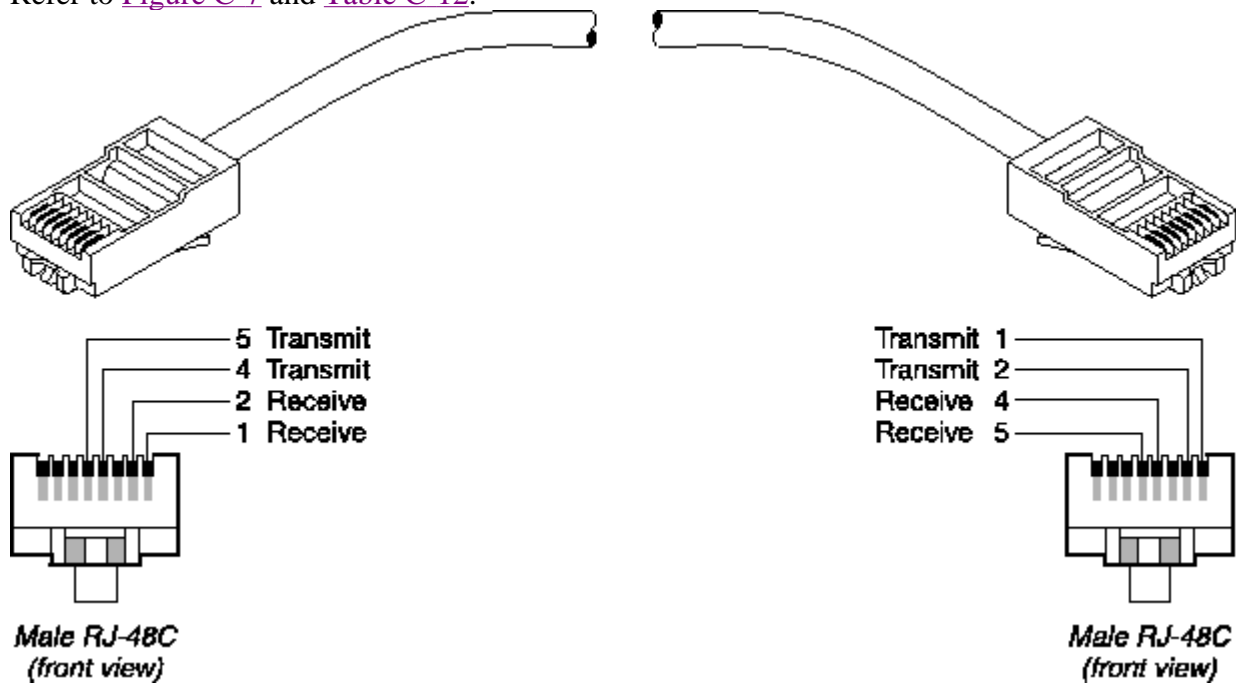

Figure C-7. RJ48C/RJ48C crossover cable

Table C-12. RJ48C/RJ48C crossover cable specifications

Model number RJ48C-X			
Part number 2510-0059/0323-001			
Pair #	Signal (MAX)	Male RJ48C (MAX)	Male RJ48C (remote)
1	Receive	2	5
		1	4
2	Transmit	5	2
		4	1

E1/PRI straight-through cable: RJ48C/RJ48C

Before installing this cable, verify that the WAN interface transmits on pins 2 and 1 and receives on pins 5 and 4. Refer to [Figure C-8](#) and [Table C-13](#).

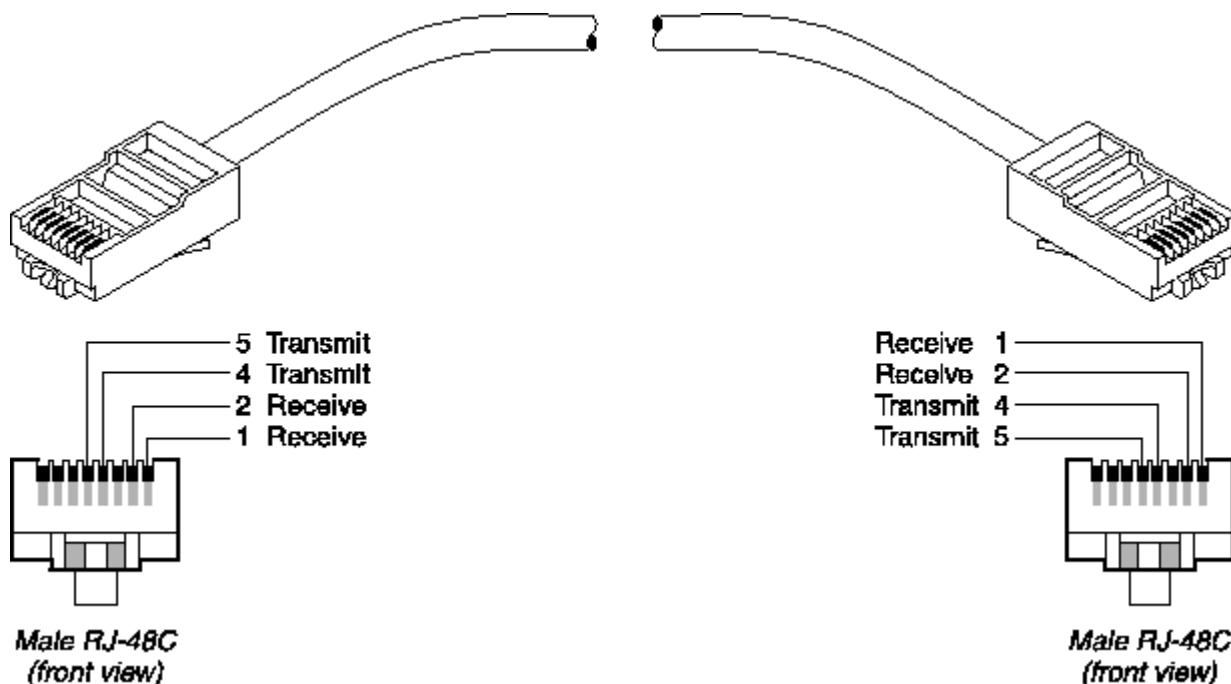

Figure C-8. RJ48C/RJ48C straight-through cable specifications

Table C-13. RJ48C/RJ48C straight-through cable specifications

Model number RJ48C-S			
Part number 2510-0064-001			
Pair #	Signal (MAX)	Male RJ48C (MAX)	Male RJ48C (remote)
1	Receive	1	1
		2	2
2	Transmit	5	5
		4	4

E1/PRI straight-through cable: RJ48C/DA-15

Before installing this cable, verify that the WAN interface transmits on pins 3 and 11 and receives on pins 1 and 9. Refer to [Figure C-9](#) and [Table C-14](#).

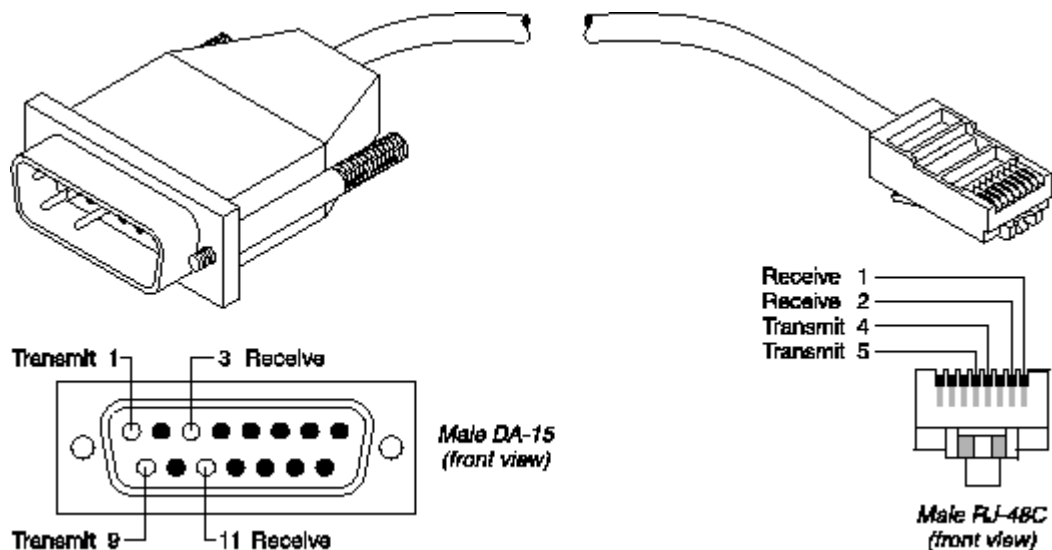

Figure C-9. RJ48C/DA-15 straight-through cable

Table C-14. RJ48C/DA-15 straight-through cable specifications

Model number DA15-X			
Part number 2510-0082-001			
Pair #	Signal (MAX)	Male RJ48C (MAX)	Male DA-15P (remote)
1	Receive	1	3
		2	11
2	Transmit	5	1
		4	9

E1/PRI crossover cable: RJ48C/DA

Before installing this cable, verify that the WAN interface transmits on pins 1 and 9 and receives on pins 3 and 11. Refer to [Figure C-10](#) and [Table C-15](#).

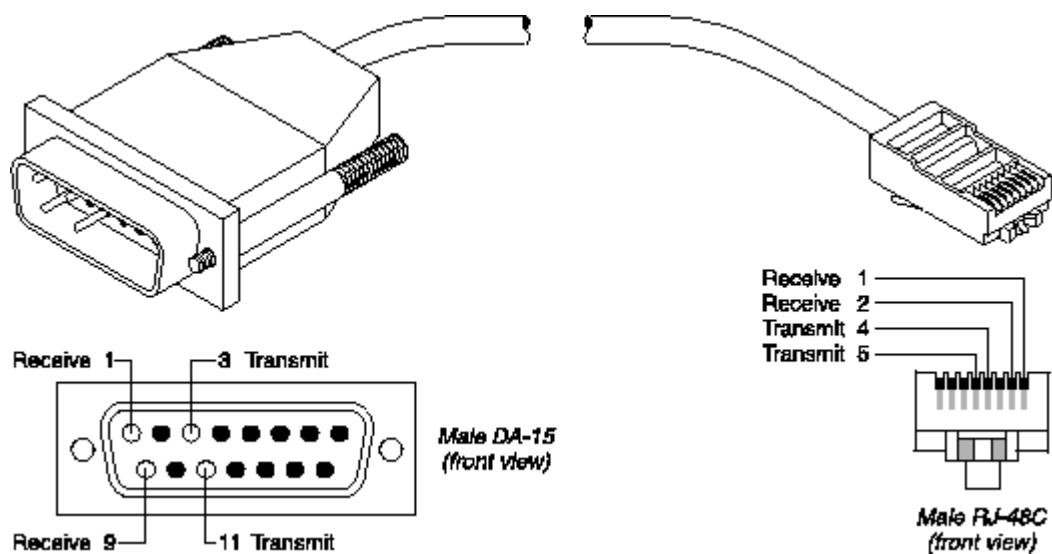

Figure C-10. RJ48C/DA crossover cable

Table C-15. RJ48C/DA crossover cable specifications

Model number DA15-S			
Part number 2510-0065-001			
Pair #	Signal (MAX)	Male RJ48C (MAX)	Male DA-15P (remote)
1	Receive	1	1
		2	9
2	Transmit	5	3
		4	11

E1/PRI straight-through cable: RJ48C/Bantam

The WAN side of the cable connects to dual bantam jacks. Refer to [Figure C-11](#) and [Table C-16](#).

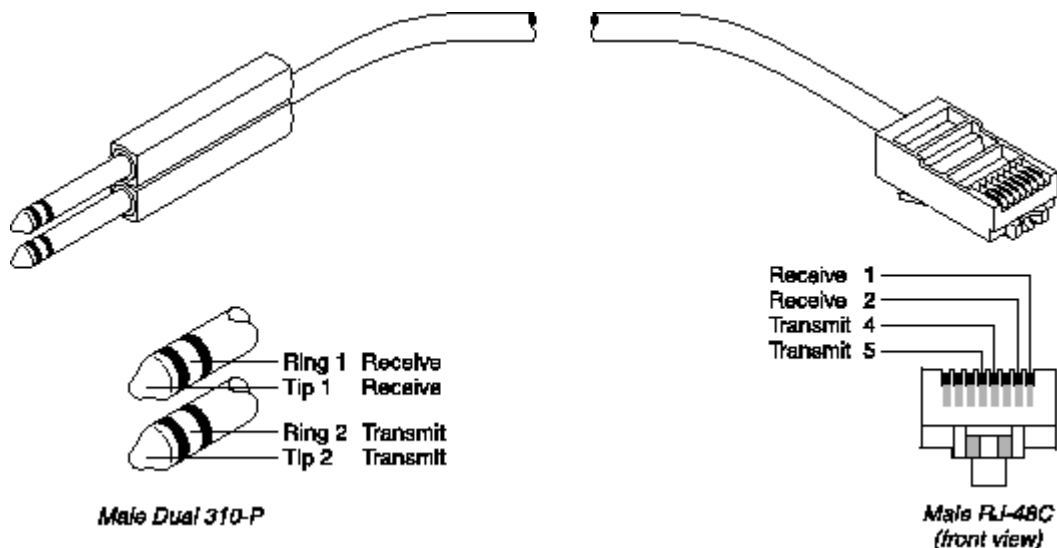

Figure C-11. RJ48C/Bantam straight-through cable

Table C-16. RJ48C/Bantam straight-through cable specifications

Model number DBNT-RJ45			
Part number 2510-0066-001			
Pair #	Signal (MAX)	Male RJ48 (MAX)	Male Dual - 310P (remote)
1	Receive	1	Tip 1
		2	Ring 1
2	Transmit	5	Tip 2
		4	Ring 2

E1/PRI straight-through cable: MAX 6000 BNC to RJ-48C

This cable adapts a modular E1 port on the MAX to coaxial cable E1 lines. You must also set the

jumpers within the MAX for 50 Ohm service. Refer to [Figure C-12](#) and [Table C-17](#).

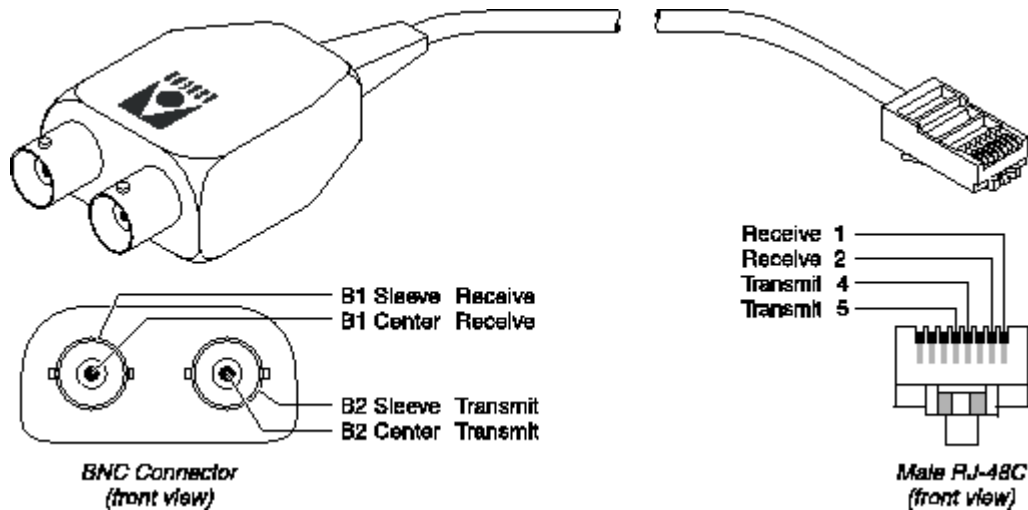

Figure C-12. MAX 6000 BNC to RJ-48C straight-through cable

Table C-17. MAX 6000 BNC to RJ-48C straight-through cable specifications

Part number 2510-0272-001			
Pair #	Signal (MAX)	Male RJ48-C (MAX)	Male Dual - BNC (remote)
1	Transmit	4	B1 Sleeve
		5	B1 Center
2	Receive	1	B2 Sleeve
		2	B2 Center

E1/PRI WAN ports

[Table C-18](#) lists the pins on RJ48C sockets on the MAX used for E1/PRI WAN interface. Only pins 1, 2, 4, and 5 are used. The remaining pins are not connected.

Table C-18. Transmit and Receive pins

MAX E1/PRI interface	RJ48C DTE
Receive (input) pair, Tip (T1)	Position 2
Receive (input) pair, Ring (R1)	Position 1
Transmit (output) pair, Tip (T)	Position 5
Transmit (output) pair, Ring (R)	Position 4

Note: E1/PRI models are also equipped with BNC connectors.

ISDN BRI interface specifications

This section provides the specifications for the MAX unit's ISDN BRI interface.



Warning: To reduce the risk of fire, communication cable conductors must be 26 AWG or larger.

Attention: Afin de reduire les risques d'incendie, les fils conducteurs du cable de communication doivent etre d'un calibre minimum de 26 AWG (American Wire Gauge), c'est-a-dire d'un minimum de 0,404 mm.

Warnung: Um Feuerrisiken zu reduzieren, müssen die Kommunikationskabel-Anschlüsse 26 AWG oder größer sein.

For the Net/BRI module

The Net/BRI module (MX-SL-8BRIN) connects to the WAN through a network termination (NT1) device. You must install a cable from the NT1 that ends in a 100Ohm termination. The maximum distance between the NT1 and its termination is 3280 feet (1000 m). You can install the Net/BRI module anywhere along the length of the cable. Use only cable specifically constructed for ISDN BRI interfaces.

Note: In Belgium, install 10 m of cable between the Net/BRI module and the NT1. Significant data errors can result from using shorter cables.

For the Host/BRI module

Each ISDN BRI line provided by the Host/BRI module (MX-SL-8BRIT) must end in a 100Ohm termination. The maximum cable distance between the Host/BRI and its termination is 3280 feet (1000 m). You can install the local ISDN BRI device anywhere along the length of the cable. Use only cable specifically constructed for ISDN BRI "S" interfaces.

Serial host interface specifications

This section describes the cabling requirements, timing requirements, and interface types for the serial host ports on the MAX.

The MAX unit's serial host ports are compatible with the following three electrical standards:

- RS-449/422
- V.35
- X.21

The MAX also supports the following dialing/answering protocols at any of its serial host ports:

- V.25 bis
- RS-366
- X.21

Selection of the proper cable between a serial host port and the serial device ensures:

- The proper mapping of pinouts from the MAX to the application equipment
- Proper voltage levels

In the cable wiring tables that follow, the MAX is the DCE (Data Circuit-Terminating Equipment) device, while the host equipment is the DTE (Data Terminal Equipment) device. The serial host interface cabling tables use the abbreviations listed in [Table C-19](#). Note that the Send timing and Receive timing clocks are supplied to the host by the MAX.

Table C-19. Serial host interface cabling abbreviations

Abbreviation	Explanation
FGND	Chassis Ground
SGND	Receive Common Ground
SD+	Send Data +
SD-	Send Data -
RD+	Receive Data +
RD-	Receive Data -
ST+	Send Timing +
ST-	Send Timing -
RT+	Receive Timing +
RT-	Receive Timing -
TT+	Terminal Timing +
TT-	Terminal Timing -
DSR	Data Set Ready
DCD (CD)	Data Carrier Detect
RTS	Request to Send
RI	Ring Indicate
DTR	Data Terminal Ready
DPR	RS-366 Call Digit or Tone
ACR	Abandon Call/Retry
CRQ	Call Request
PND	Present Next Digit
DLO	Data Line Occupied
NB1	RS-366 Call Digit or Tone
NB2	RS-366 Call Digit or Tone
NB4	RS-366 Call Digit or Tone
NB8	RS-366 Call Digit or Tone
RX/SEL	Select Interface Jumper (not a signal to or from host)

V.35 cabling

The sections that follow list the pinouts for different types of V.35 cabling.

V.35/V.25 bis cable to Cisco

This cable connects the MAX to the V.35 port of a Cisco router that uses V.25 bis dialing. [Figure C-13](#) and [Table C-20](#) list the V.35/V.25 bis cable pinouts.

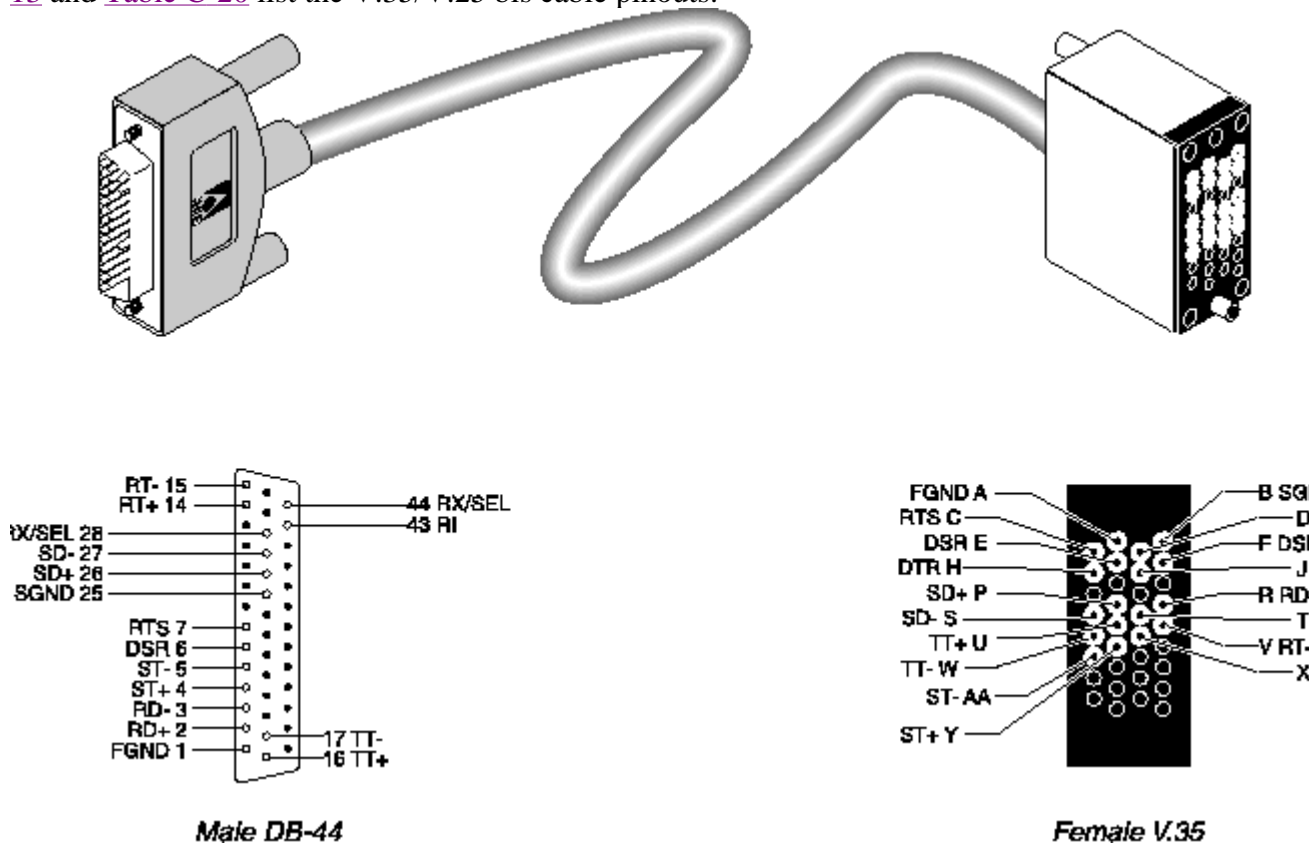

Figure C-13. V.35/V.25 bis cable to Cisco
 Table C-20. V.35/V.25 bis cable to Cisco pinouts

Pair #	Signal (MAX)	MAX male DB-44 (MAX)	Host female V.35
1	FGND	1	A
2	SD+	26	P
	SD-	27	S
3	RD+	2	R
	RD-	3	T
4	ST+	4	Y
	ST-	5	AA
5	RT+	14	V
	RT-	15	X
6	DSR	6	E, F*
	DCD	36	D
	RTS	7	C

7	RI	43	J
8	DTR	8	H
	SGND	25	B
9	TT+	16	U
	TT-	17	W
10	RX/SEL	28, 44*	

Note: *Pin positions separated by commas are jumped to each other.

V.35 cable to generic serial host

This cable connects the MAX to the V.35 ports of a wide variety of equipment. A female-to-male V.35 gender changer is included when you order the cable. [Table C-21](#) lists the V.35 cable pinouts.

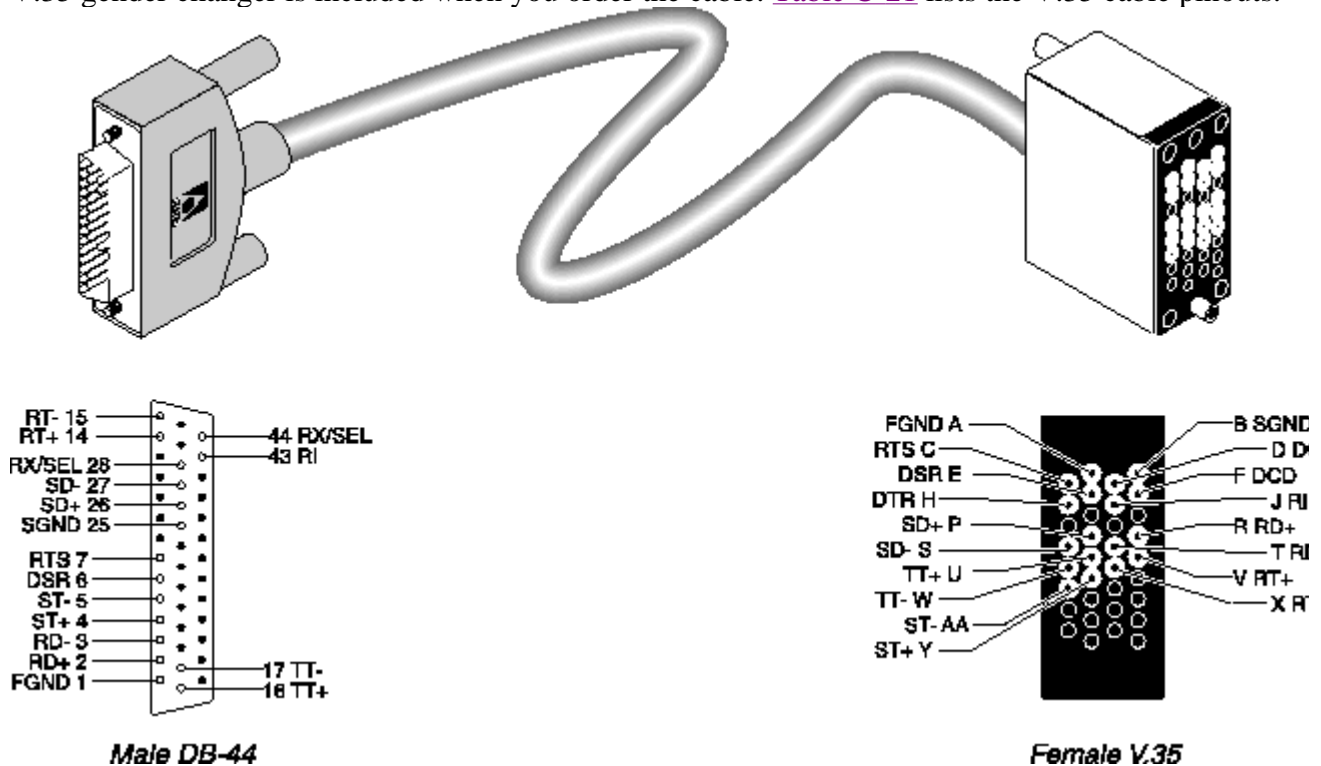

Figure C-14. V.35 cable to generic serial host
 Table C-21. V.35 cable to generic serial host pinouts

Pair #	Signal (MAX)	MAX male DB-44 (MAX)	Host female V.35
1	FGND	1	A
2	SD+	26	P
	SD-	27	S
	RD+	2	R

3	RD-	3	T
4	ST+	4	Y
	ST-	5	AA
5	RT+	14	V
	RT-	15	X
6	DSR	6	E
	DCD	36	D, F*
7	RTS	7	C
	RI	43	J
8	DTR	8	H
	SGND	25	B
9	TT+	16	U
	TT-	17	W
10	RX/SEL	28, 44*	

Note: *Pin positions separated by commas are jumped to each other.

V.35/RS-366 cable to generic serial host

This cable connects the MAX to the V.35 ports of a wide variety of equipment using RS-366 dialing. A female-to-male V.35 gender changer is included when you order the cable. [Figure C-15](#) and [Table C-22](#) list the V.35/RS-366 cable pinouts.

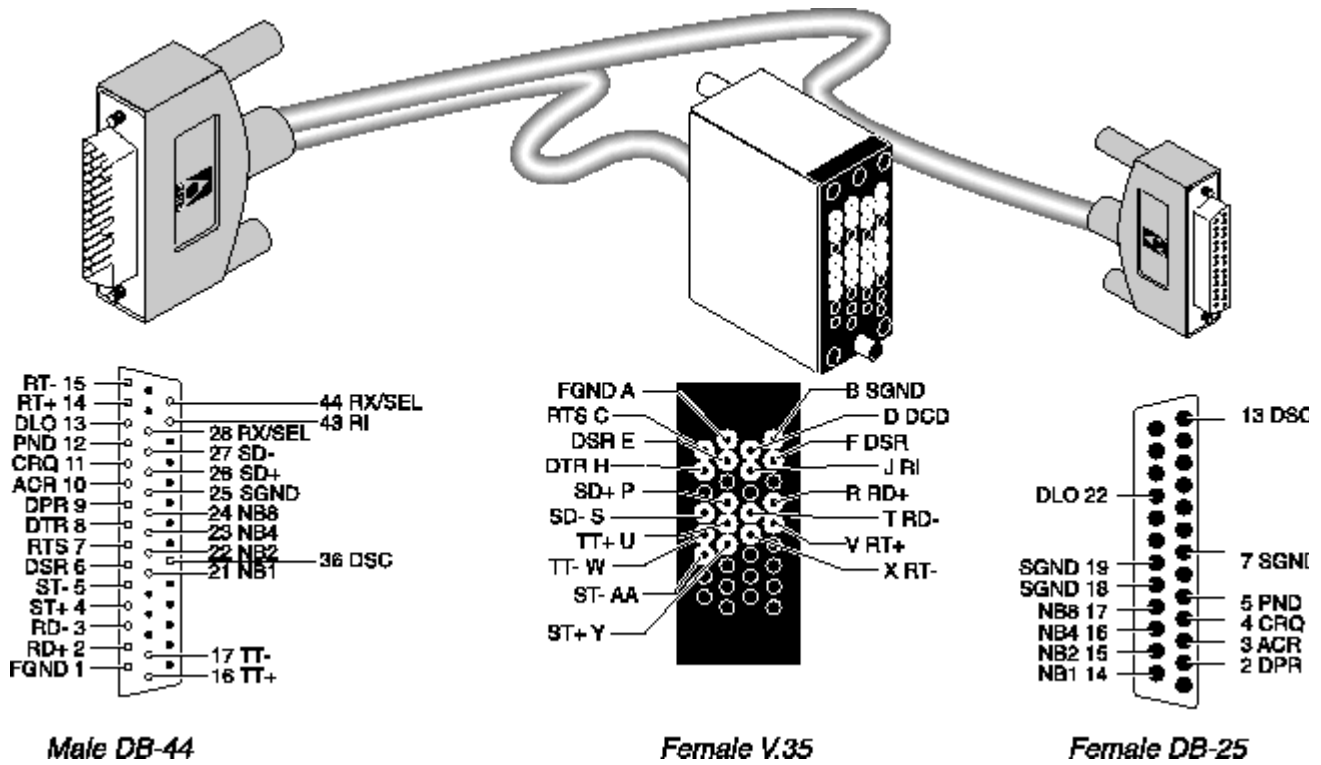

Figure C-15. V.35/RS-366 cable to generic serial host

Table C-22. V.35/RS-366 cable to generic serial host pinouts

Model number MBHD-V35-366				
Part number 2510-0077-001				
Pair #	Signal (MAX)	MAX male DB-44 (MAX)	Host female V.35	RS-366 Female DB-25
1	FGND	1	A	
2	SD+	26	P	
	SD-	27	S	
3	RD+	2	R	
	RD-	3	T	
4	ST+	4	Y	
	ST-	5	AA	
5	RT+	14	V	
	RT-	15	X	
6	DSR	6	E	
	DCD/CTS	36	D, F*	
7	RTS	7	C	
	RI	43	J	

8	DTR	8	H	
	SGND	25	B	
9	TT+	16	U	
	TT-	17	W	
10	DPR	9		2
	ACR	10		3
11	CRQ	11		4
	PND	12		5
12	DLO	13		22
	SGND	25		7, 18, 19*
13	NB1	21		14
	NB2	22		15
14	NB4	23		16
	NB8	24		17
15	DSC	36		13
16	RX/SEL	28, 44*		
* Pin positions separated by commas are jumped to each other.				

V.35/RS-366 cable to CLI

This cable connects the MAX to the V.35 port of the Compression Labs Rembrandt II codec with support for RS-366 dialing. [Figure C-16](#) and [Table C-23](#) list the V.35/RS-366 cable pinouts.

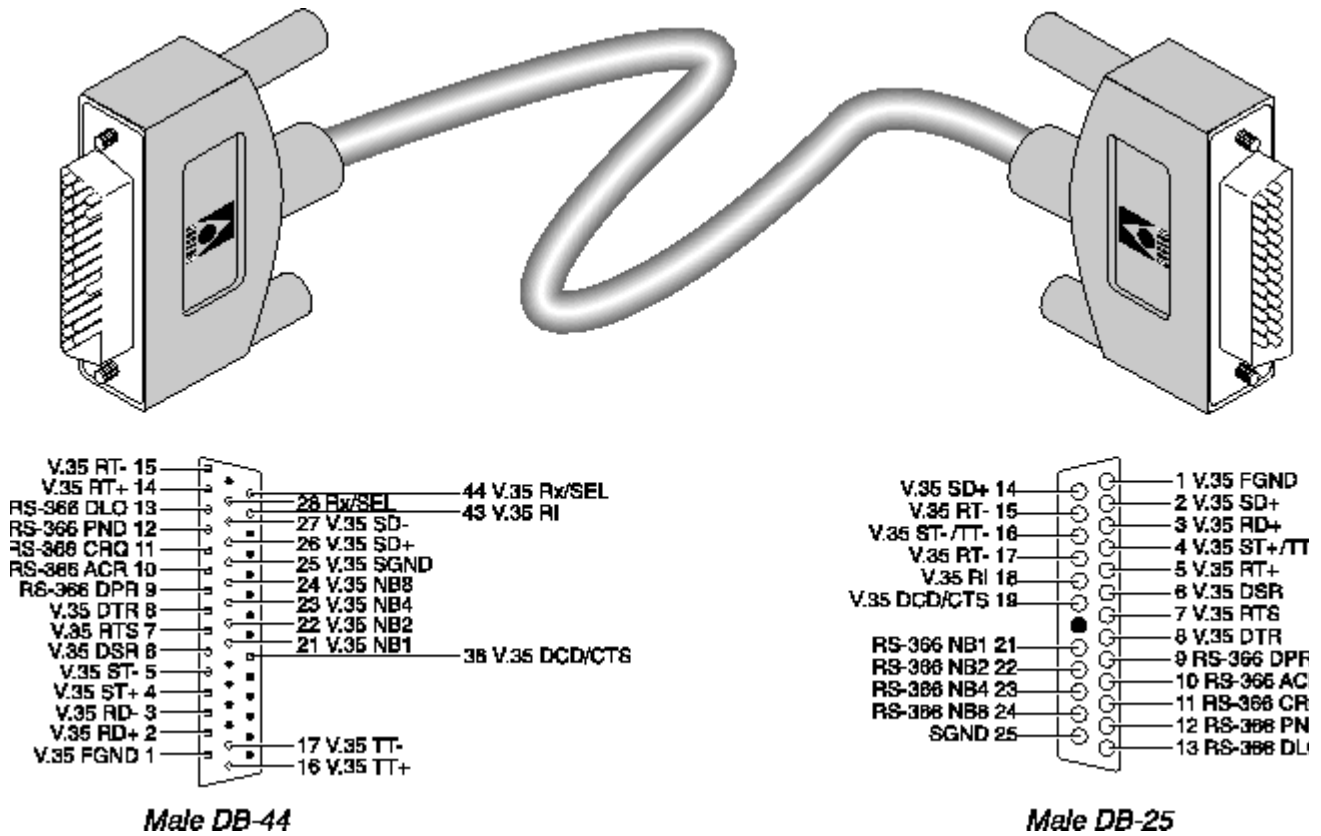

Figure C-16. V.35/RS-366 cable to CLI codec
 Table C-23. V.35/RS-366 cable to CLI pinouts

Pair #	Signal (MAX)	MAX male DB-44 (MAX)	Host V.35/RS-366 male DB-25
1	V.35 FGND	1	1
	V.35 DTR	8	8
2	V.35 SD+	26	2
	V.35 SD-	27	14
3	V.35 RD+	2	3
	V.35 RD-	3	15
4	V.35 ST+	4	4
	V.35 ST-	5	16
5	V.35 RT+	14	5
	V.35 RT-	15	17
6	V.35 DSR	6	6
	V.35 DCD/CTS	36	19
7	V.35 RTS	7	7
	V.35 RI	43	18

8	V.35 TT+	16	4
	V.35 TT-	17	16
9	RS-366 DPR	9	9
	RS-366 ACR	10	10
10	RS-366 CRQ	11	11
	RS-366 PND	12	12
11	RS-366 DLO	13	13
	SGND	25	25
12	RS-366 NB1	21	21
	RS-366 NB2	22	22
13	RS-366 NB4	23	23
	RS-366 NB8	24	24
14	RX/SEL	28, 44*	

* Pin positions separated by commas are jumped to each other.

V.35/RS-366 cable to PictureTel

This cable connects the MAX to the V.35 port of the PictureTel codec with support for RS-366 dialing. [Figure C-17](#) and [Table C-24](#) list the V.35/RS-366 cable pinouts.

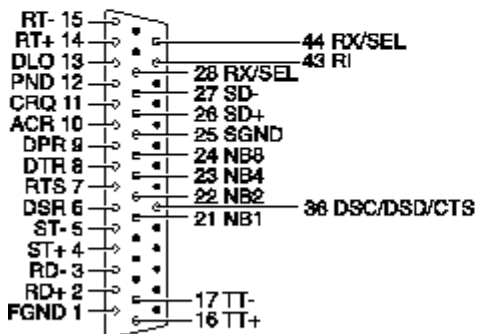
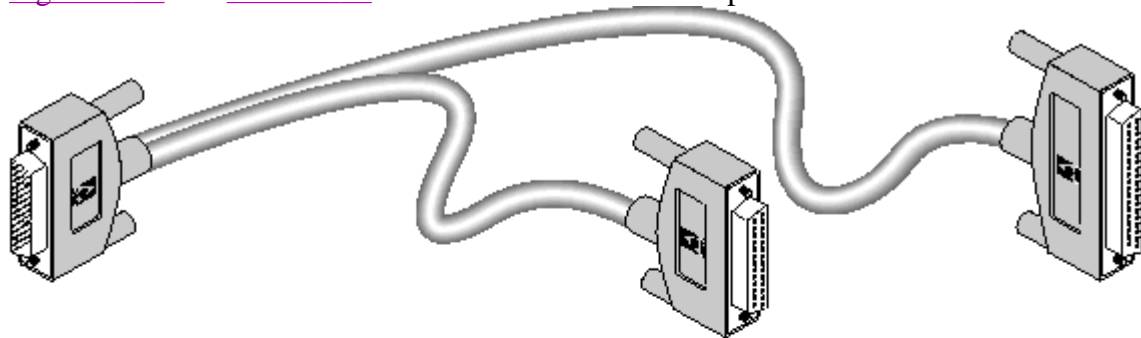

Male DB-44

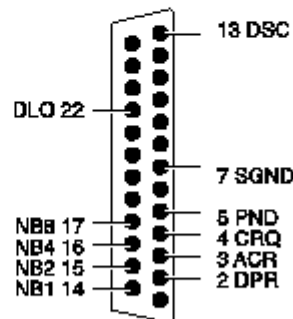

Female DB-25

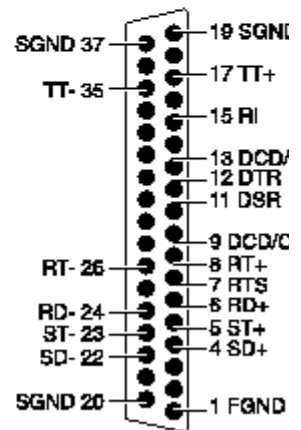

Female DB-37

Figure C-17. V.35/RS-366 cable to PictureTel

Table C-24. V.35/RS-366 cable to PictureTel pinouts

Model number MBHD-449PT				
Part number 2510-0093-001				
Pair #	Signal (MAX)	MAX male DB-44 (MAX)	Host female DB-37	RS-366 Female DB-25
1	FGND	1	1	
2	SD+	26	4	
	SD-	27	22	
3	RD+	2	6	
	RD-	3	24	
4	ST+	4	5	
	ST-	5	23	
5	RT+	14	8	
	RT-	15	26	
6	DSR	6	11	
	DCD/CTS	36	9, 13*	
7	RTS	7	7	
	RI	43	15	
8	DTR	8	12	
	SGND	25	19, 20, 37*	
9	TT+	16	17	
	TT-	17	35	
10	DPR	9		2
	ACR	10		3
11	CRQ	11		4
	PND	12		5
12	DLO	13		22
	SGND	25		7
13	NB1	21		14
	NB2	22		15
14	NB4	23		16

	NB8	24		17
15	DSC	36		13
16	RX/SEL	28, 44*		

Note: *Pin positions separated by commas are jumped to each other.

RS-366 cabling

Ascend supplies a variety of RS-366 cables. The sections that follow list the pinouts for different types of RS-366 cabling.

RS-449 / RS-366 / DB-37 cable to Video Telecom

This cable connects the MAX to the RS-449 port of a Video Telecom codec with support for RS-366 dialing. [Figure C-18](#) and [Table C-25](#) list the RS-449 / RS-366 / DB-37 cable pinouts.

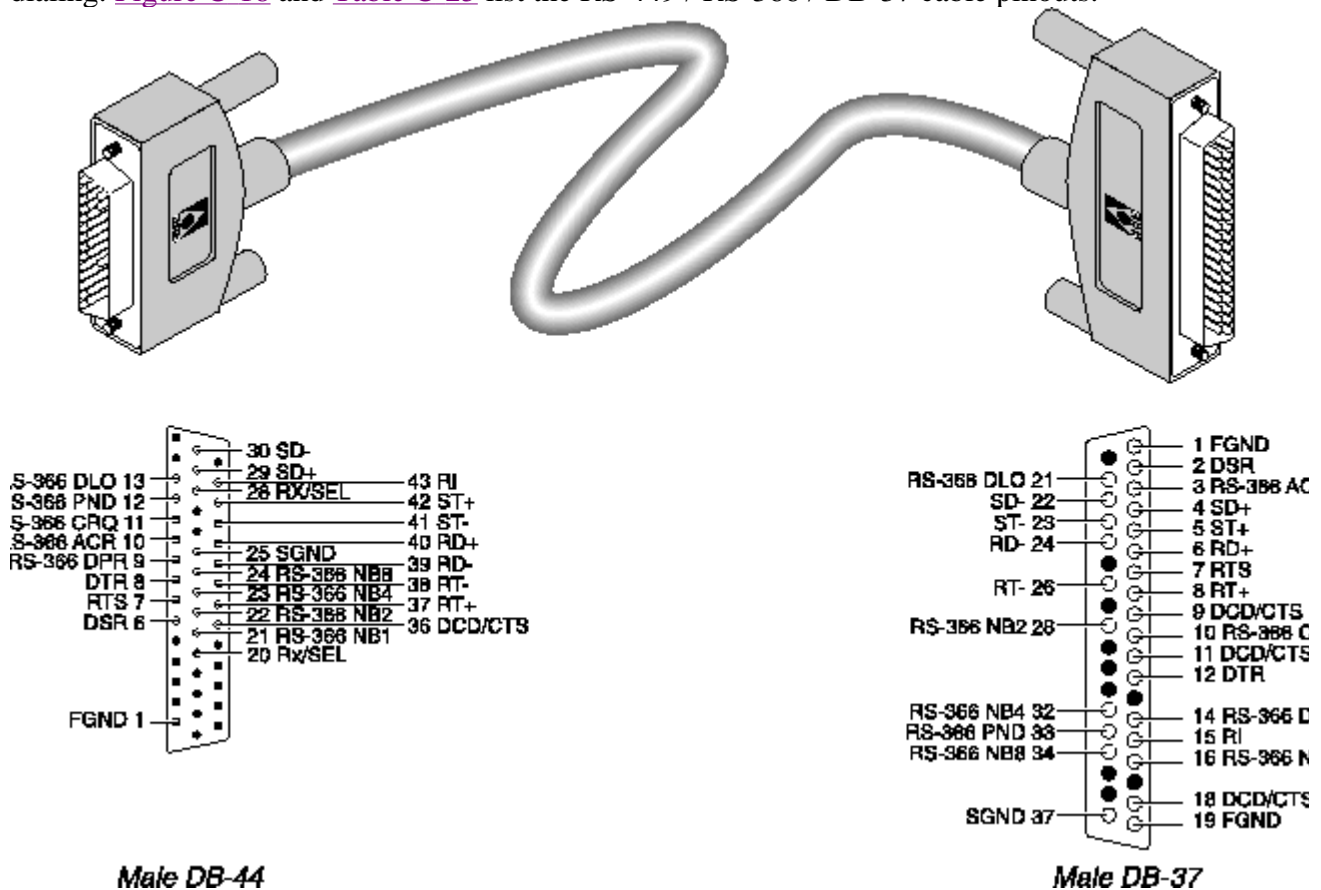

Figure C-18. RS-449/RS-366/DB-37 cable to Video Telecom codec
 Table C-25. RS-449 / RS-366 / DB-37 cable to VTC pinouts

Pair #	Signal (MAX)	MAX male DB-44 (MAX)	Host RS-449/RS-366 male DB-37
1	FGND	1	1
	FGND	1	19

2	SD+	29	4
	SD-	30	22
3	RD+	40	6
	RD-	39	24
4	ST+	42	5
	ST-	41	23
5	RT+	37	8
	RT-	38	26
6	DSR	6	2
	DCD/CTS	36	9, 11, 18*
7	RTS	7	7
	RI	43	15
8	DTR	8	12
	SGND	25	37
9	RS-366 DPR	9	14
	RS-366 ACR	10	3
10	RS-366 CRQ	11	10
	RS-366 PND	12	33
11	RS-366 DLO	13	21
12	RS-366 NB1	21	16
	RS-366 NB2	22	28
13	RS-366 NB4	23	32
	RS-366 NB8	24	34
14	RX/SEL	20, 28*	

Note: * Pin positions separated by commas are jumped to each other. This cable does not support terminal timing.

RS-449/RS-366 cable to generic serial host

This cable connects the MAX to the RS-449 ports of a wide variety of equipment using RS-366 dialing. A female-to-male DB-37 gender changer is included when you order the cable. [Figure C-19](#) and [Table C-26](#) list the RS-449/RS-366 cable pinouts.

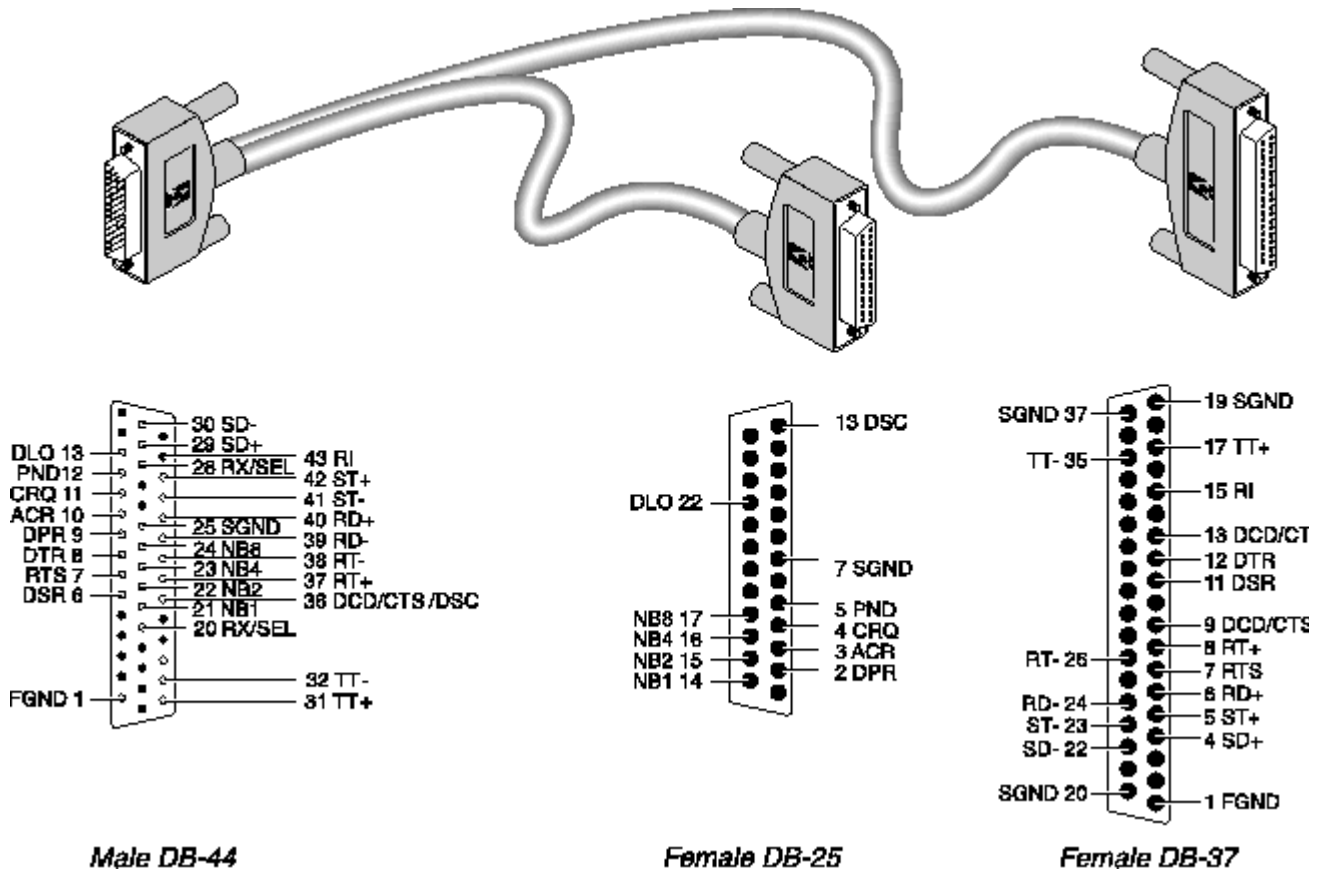

Figure C-19. RS-449/RS-366 cable to generic serial host

Table C-26. RS-449/RS-366 cable to generic serial host pinouts

Model number MBHD-449-366				
Part number 2510-0078-001				
Pair #	Signal (MAX)	MAX male DB-44 (MAX)	Host female DB-37	RS-366 Female DB-25
1	FGND	1	1	
2	SD+	29	4	
	SD-	30	22	
3	RD+	40	6	
	RD-	39	24	
4	ST+	42	5	
	ST-	41	23	
5	RT+	37	8	
	RT-	38	26	
6	DSR	6	11	
	DCD/CTS	36	9, 13*	
	RTS	7	7	

7	RI	43	15	
8	DTR	8	12	
	SGND	25	19, 20, 37*	
9	TT+	31	17	
	TT-	32	35	
10	DPR	9		2
	ACR	10		3
11	CRQ	11		4
	PND	12		5
12	DLO	13		22
	SGND	25		7
13	NB1	21		14
	NB2	22		15
14	NB4	23		16
	NB8	24		17
15	DSC	36		13
16	RX/SEL	20, 28*		

Note: *Pin positions separated by commas are jumped to each other.

RS-449 cable to generic serial host

This cable connects the MAX to the RS-449 ports of a wide variety of equipment. A female-to-male DB-37 gender changer is included when you order the cable. [Table C-27](#) lists the RS-449 cable pinouts.

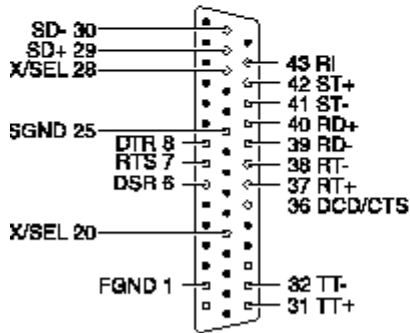
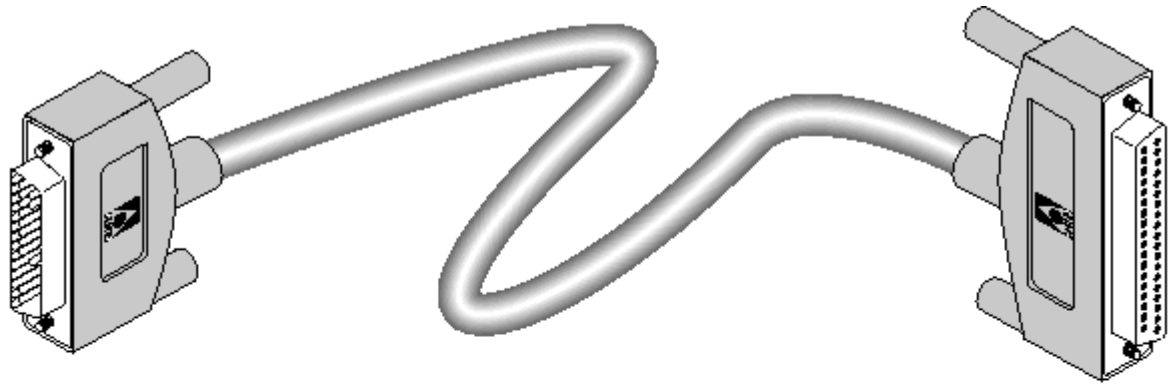

Male DB-44

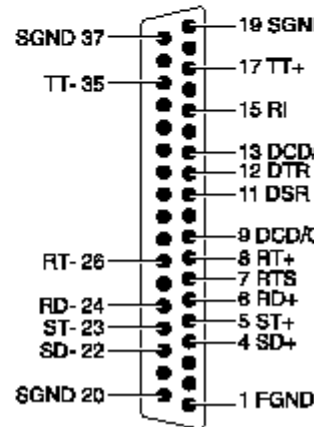

Female DB-37

Figure C-20. RS-449 cable to generic serial host

Table C-27. RS-449 cable to generic serial host pinouts

Pair #	Signal (MAX)	MAX male DB-44 (MAX)	Host female DB-37
1	FGND	1	1
2	SD+	29	4
	SD-	30	22
3	RD+	40	6
	RD-	39	24
4	ST+	42	5
	ST-	41	23
5	RT+	37	8
	RT-	38	26
6	DSR	6	11
	DCD/CTS	36	9, 13*
7	RTS	7	7
	RI	43	15

8	DTR	8	12
	SGND	25	19, 20, 37*
9	TT+	31	17
	TT-	32	35
10	RX/SEL	20, 28*	

* Pin positions separated by commas are jumped to each other.

Note: To manufacture an RS-449 cable for Cisco routers, use the above wiring list and connect the following DB-37 pins to SGND:

- DSR- (pin 29)
- CD- (pin 31)
- CTS- (pin 27).

X.21 cabling

Ascend supplies a single X.21 cable.

X.21 cable to generic serial host

If your host is equipped with an X.21 interface, [Figure C-21](#) and [Table C-28](#) list the pinouts for the host cable.

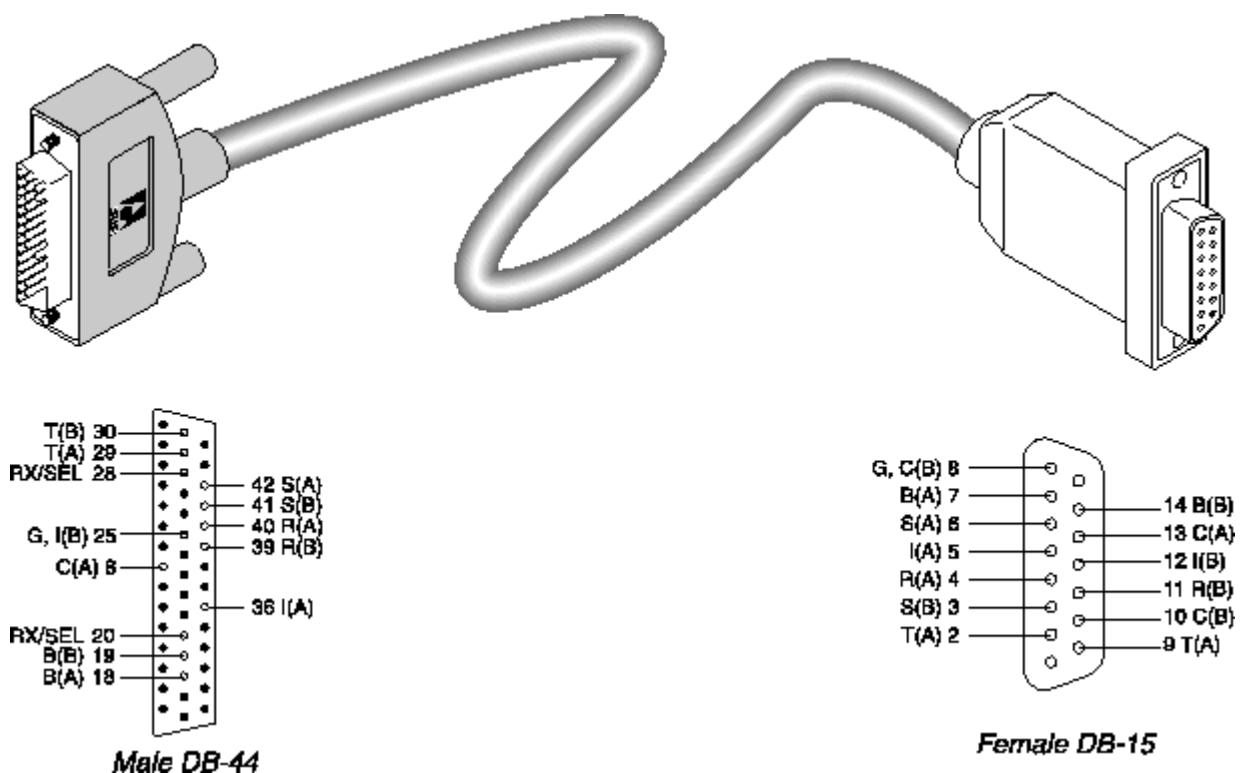

Figure C-21. X.21 cable to generic serial host

Table C-28. X.21 cable to generic serial host pinouts

Model Number MBHD-X21				
Part number 2510-0098-001				
Pair #	X.21 signal name (MAX)	Equivalent V.35/RS-449 signal name (MAX)	MAX male DB-44 (MAX)	Host Female DA-15
1	G*	SGND*	25*	8
2	T(A) T(B)	SD+ SD-	29 30	2 9
3	R(A) R(B)	RD+ RD-	40 39	4 11
4	S(A) S(B)	ST+ ST-	42 41	6 13
5	C(A) I(A)	DTR DCD	8 36	3 5
6	RX/SEL I(B)*	RX/SEL SGND*	20, 28** 25***	12***
7	B(A) B(B)	BT+ BT-	18 19	7 14
8	C(B)			8, 10****

Note:

Both I(B) and G connect to SGND, pin 25 on DB-44.
Pins 20 and 28 on the DB-44 interface are jumped together.
Connect pin 25 (DB-44) to pin 12 (DA-15) through a 200 Ohm resistor.
Connect pin 8 (DA-15) to pin 10 (DA-15) through a 200 Ohm resistor.

Cable length requirements

Table C-29 specifies the recommended maximum length of the cable between the MAX and the serial host equipment. Longer distances at the specified data rates are possible when you use terminal timing, and still longer distances are supported by the installation of the Ascend RPM, a hardware device that provides an extended distance high-speed link between the MAX and the serial host equipment.

Table C-29. Cable length requirements

Max cable length	Serial data rate
25 feet	3 Mbps
75 feet	2 Mbps
150 feet	512 kbps

Serial WAN cabling specifications

The MAX unit's serial WAN interface supports nailed-up connections to the WAN. Data packets from the MAX unit's bridge/router module can use this interface, but bit streams from devices connected to the MAX unit's serial host ports cannot.

The MAX unit's serial WAN port is compatible with the following two electrical standards:

- V.35
- RS-449/422

In the cable wiring tables that follow, the MAX is the DTE (Data Terminal Equipment) that connects to a DCE (Data Circuit-Terminating Equipment) device through its serial WAN port. The MAX receives the Send timing and Receive timing clocks from the DCE device.

V.35 cable to WAN

You connect a V.35 cable to the V.35 port of a DCE device. [Table C-30](#) describes the V.35 cable pinouts.

Table C-30. V.35 cable pinouts

Pair #	Signal (MAX)	MAX male DB-44 (MAX)	Host male V.35
1	FGND	1	A
	RI	8	J
2	SD+	39	P
	SD-	40	S
3	RD+	30	R
	RD-	29	T
4	ST+	41	Y
	ST-	42	AA
5	RT+	32	V
	RT-	31	X
6	TT+	38	U
	TT-	37	W
7	DTR	6	H
	DSR	11	E
8	DCD	9	F
	SGND	25	B

9	CTS	7	D
	RTS	36	C

RS-449 cable to WAN

You can connect an RS-449 cable to the RS-449 port of a DCE device. The RS-449 cable has the pinouts described in

Table C-31. RS-449 cable pinouts

Pair #	Signal (MAX)	MAX male DB-44 (MAX)	Host female DB-37
1	FGND	1	1
	RI	8	15
2	SD+	39	4
	SD-	40	22
3	RD+	30	6
	RD-	29	24
4	ST+	41	5
	ST-	42	23
5	RT+	32	8
	RT-	31	26
9	TT+	38	17
	TT-	37	35
8	DTR	6	12
	DSR	11	11
6	DCD	9	13
	SGND	25	19, 20, 37*
7	CTS	7	9
	RTS	36	7

Table C-31.

Note: *Pin positions separated by commas are jumped to each other.

IDSL specifications

Voice Channels	2
Transfer rate	128 Kbps (symmetric)
Transmission distance	18,000 feet
Interfaces per card	8 ports per card, up to 6 cards per system
Physical connectors	RJ45
Connector requirements	Must meet JIS C 5973 standards
Card dimensions	5.6 in high x 10.7 in long (14.2 cm x 27 cm)
Card weight	~2 pounds (0.9 kg)
Operating humidity	0-90%, non-condensing
Operating temperature	32-104 F (0-40 C)

Features

Network Interface Specifications	<ul style="list-style-type: none"> • 18,000 feet over twisted copper pair • AT&T Point-to-Point • 2B1Q signaling compatible • data only at 128 Kbps (symmetric) <p>Compatible with:</p> <ul style="list-style-type: none"> • ANSI T1.601-1991 • CNET specification technique ST/LAA/ELR/DNP/822 • ETSI DTR/TM 3002 • Recommendation CCITT G961 • most of the commercially available 2B1Q band ISDN BRI terminal adapters, bridges and routers
Loopback Testing	<ul style="list-style-type: none"> • Line loopback test • corrupt CRC test • request corrupt CRC test • monitoring

[HOME](#) [CONTENTS](#) [PREVIOUS](#) [NEXT](#) [INDEX](#)

techpubs@eng.ascend.com

Copyright © 1998, Ascend Communications, Inc. All rights reserved.